

MINARC T 223 DC GM

MINARC T 223 DC MLP GM

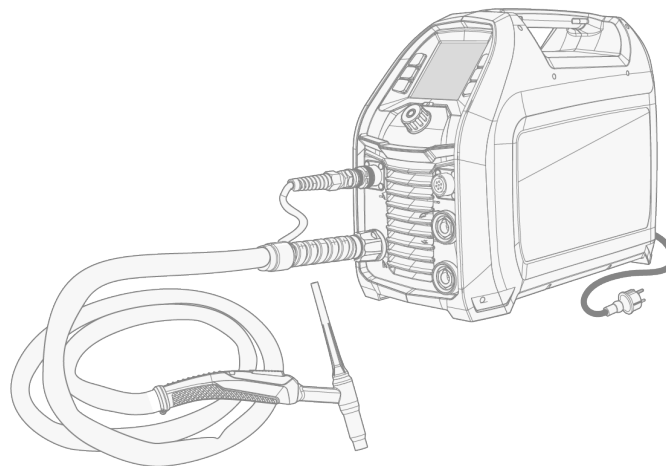

CONTENTS

1. General	3
1.1 Welding safety	4
1.2 Equipment description	5
1.3 Minarc T 223 DC power source	6
1.3.1 Minarc T 223 DC welding performance	8
2. Installation	9
2.1 Installing equipment on cart (optional)	10
2.2 Connecting TIG welding torch	12
2.3 Connecting MMA electrode holder	13
2.4 Installing remote control	14
2.5 Installing gas bottle and testing gas flow	15
2.6 Attaching carrying strap	17
3. Operation	18
3.1 Preparing welding system for use	19
3.2 Minarc T 223 DC control panels	20
3.2.1 Main view	23
3.2.2 Welding parameters	23
3.2.3 Memory channels	29
3.2.4 Weld data	29
3.3 Additional guidance to functions and features	31
3.3.1 TIG processes and current modes	31
3.3.2 Ignition modes in TIG welding	31
3.3.3 Trigger logic functions (TIG)	32
3.3.4 MMA functions and features	33
3.4 Using remote control	35
3.5 Lifting equipment	37
3.6 Troubleshooting	38
3.7 Error codes	39
4. Maintenance	40
4.1 Daily, periodic and annual maintenance	41
4.2 Disposal	43
5. Technical data	44
5.1 Minarc T 223 DC power source	45
5.2 TIG guide table	48
5.3 Minarc T 223 DC ordering info	49

1. GENERAL

These instructions describe the use of Kemppi's Minarc T 223 DC welding device designed for demanding professional use. The equipment consists of a Minarc T 223 DC power source with a control panel, an optional cooler and an optional cart.

The Minarc T 223 DC power source is suitable for TIG and MMA welding. Pulsed TIG welding requires the Minarc T 223 DC MLP (Minilog and Pulse) device model.

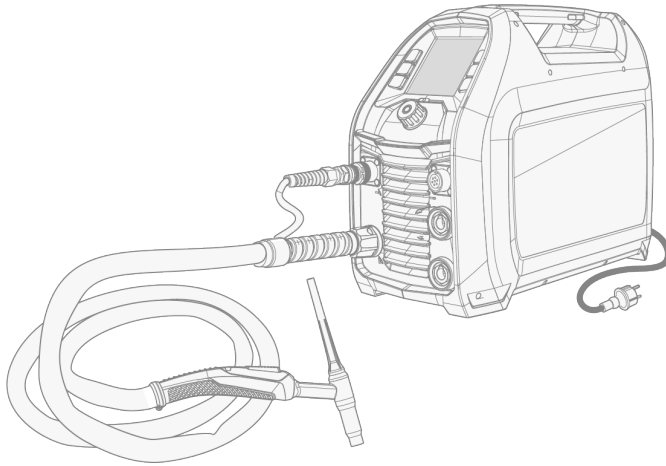



Minarc T 223 DC is designed to be used together with Kemppi's Flexlite TX TIG torches.

Important notes

Read the instructions through carefully.

Items in the manual that require particular attention in order to minimize damage and harm are indicated with the below symbols. Read these sections carefully and follow their instructions.

 *Note: Gives the user a useful piece of information.*

 *Caution: Describes a situation that may result in damage to the equipment or system.*

 *Warning: Describes a potentially dangerous situation. If not avoided, it will result in personal damage or fatal injury.*

DISCLAIMER

While every effort has been made to ensure that the information contained in this guide is accurate and complete, no liability can be accepted for any errors or omissions. Kemppi reserves the right to change the specification of the product described at any time without prior notice. Do not copy, record, reproduce or transmit the contents of this guide without prior permission from Kemppi.

The source language for this document is English. All other language versions available are either professional human translations or advanced machine translations. Any feedback regarding translation terminology can be sent to userdoc@kemppi.com.

1.1 WELDING SAFETY

Welding is always classified as hot work, and welding equipment typically contains high-voltage circuits. If you are not familiar with welding and welding principles, it is recommended that you acquire welding training or professional guidance before commencing welding. The welding equipment mentioned in this manual is intended for professional use in an industrial environment.

 *For your own safety, and that of your working environment, pay particular attention to the safety instructions delivered with the equipment.*

You can also access and download the safety instructions by using these links:

- [Safety](https://kemp.cc/safety/general)
(<https://kemp.cc/safety/general>)
- [Personal protection](https://kemp.cc/safety/ppe)
(<https://kemp.cc/safety/ppe>)
- [Welding guns and torches](https://kemp.cc/safety/torches)
(<https://kemp.cc/safety/torches>)

1.2 EQUIPMENT DESCRIPTION

Minarc T DC power sources (220 A DC)

- Minarc T 223 DC GM
 - >> Standard power source
 - >> Multi-voltage and generator compatible
 - >> Includes a 1-knob LCD control panel with 6 function buttons
 - >> Support for TIG and MMA welding processes
- Minarc T 223 DC MLP GM
 - >> MLP (Minilog and pulse) power source
 - >> Multi-voltage and generator compatible
 - >> Includes a 1-knob LCD control panel with 6 function buttons
 - >> Support for pulse TIG process and Minilog function in addition to normal TIG and MMA processes

Both power source models are also available in VRD (voltage reduction device) model versions, where the VRD function is locked on.

For the power source part descriptions, refer to "Minarc T 223 DC power source" on the next page.

Cooling unit (optional)

- Minarc Cooler 05

For more information, refer to [Kempfi Userdoc](#).

TIG welding torches

- Flexlite TX TIG torches

For more information, refer to [Kempfi Userdoc](#).

Optional accessories

- 2-wheel cart
- Remote controls

For more information on optional accessories, contact your local Kempfi dealer.

EQUIPMENT IDENTIFICATION

Serial number

Serial number of the device is marked on the rating plate or in another distinctive location on the device. It is important to make correct reference to the serial number of the product when ordering spare parts or making repairs for example.

Quick Response (QR) code

The serial number and other device-related identification information may also be saved in the form of a QR code (or a barcode) on the device. Such code can be read by a smartphone camera or with a dedicated code reader device providing fast access to the device-specific information.

1.3 MINARC T 223 DC POWER SOURCE

Front

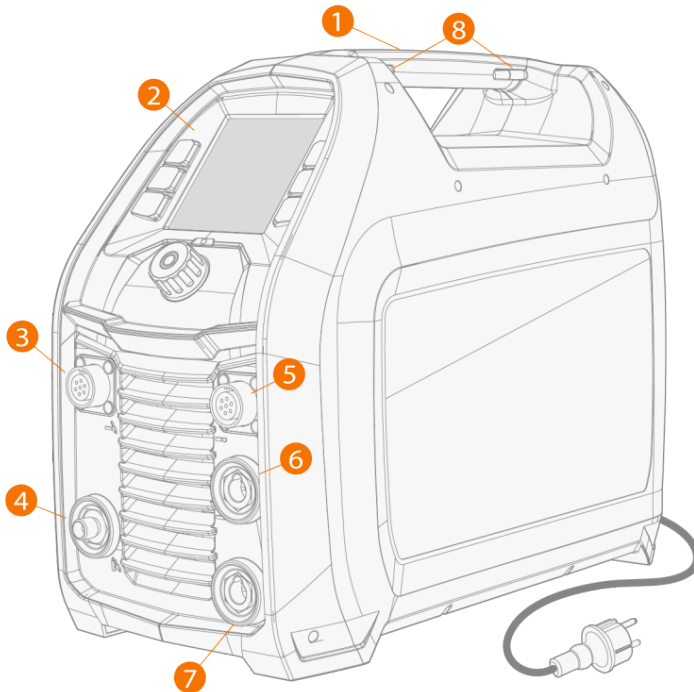

1. Lifting handle (also for mechanical lifting when the power source is not installed on a cart)
2. Control panel
3. Control cable connector
4. TIG welding cable connector
5. Remote control connector
6. Negative (-) DIX connector
>> For earth return cable in MMA welding
7. Positive (+) DIX connector
>> For earth return cable in TIG welding
>> For MMA electrode holder
8. Slots for the carrying strap

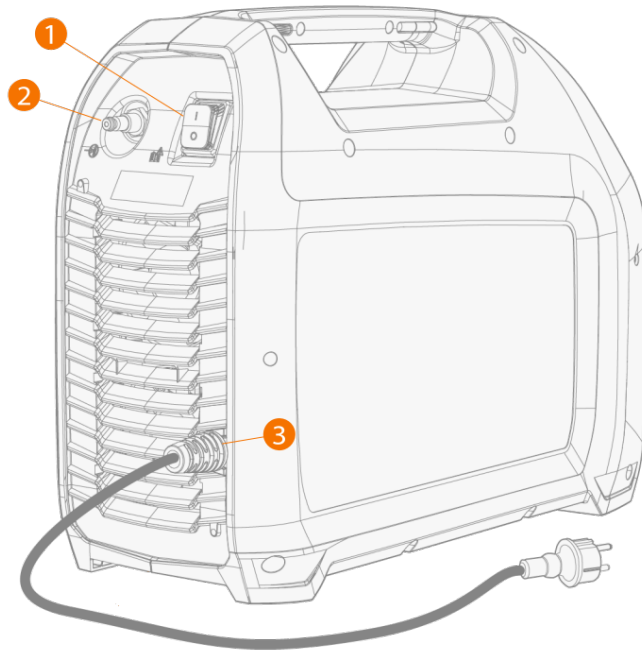
Rear

1. Power switch
2. Shielding gas hose connector
3. Mains cable

1.3.1 MINARC T 223 DC WELDING PERFORMANCE

The following describes the welding performance of Minarc T 223 DC. For technical data, refer to "Minarc T 223 DC power source" on page 45.

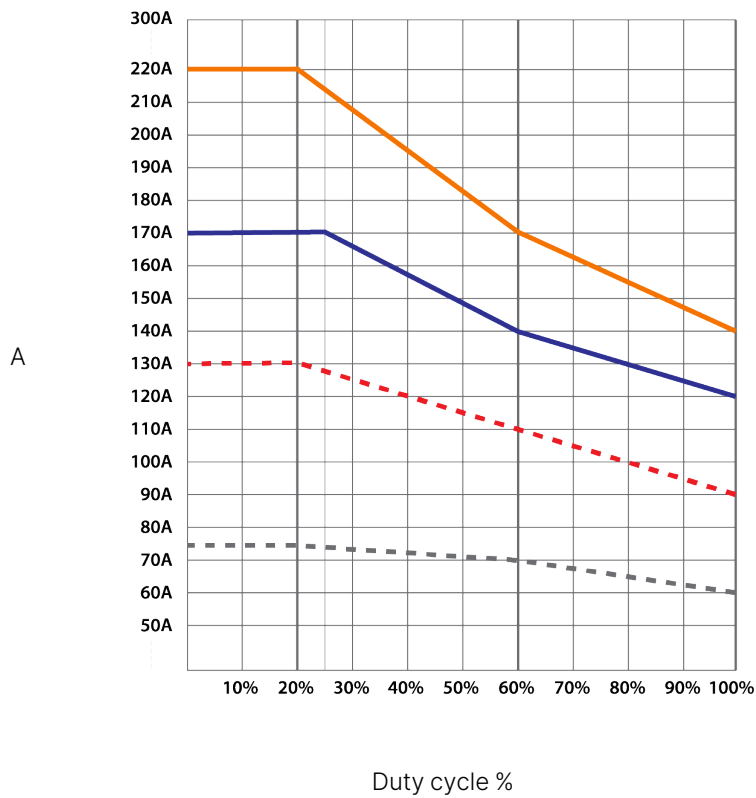

Minarc T 223 DC welding performance (40°C)



Mains connection voltage (1-phase)

- | | | | |
|-----------------|--|-----------------|---|
| TIG 220...240 V | — | MMA 220...240 V | — |
| TIG 110...120 V | - - - | MMA 110...120 V | - - - |

2. INSTALLATION

-  *Do not connect the equipment to the mains before the installation is complete.*
-  *Do not modify the welding equipment in any way, except for the changes and adjustments covered in the manufacturer's instructions.*
-  *Place the machine on a horizontal, stable and clean ground. Protect the machine from rain and direct sunshine. Check that there is enough space (> 15 cm) for cooling air circulation in the machine vicinity.*

Before installation

- Make sure to acknowledge and follow the local and national requirements regarding installation and use of high voltage units.
- Check the contents of the packages and make sure the parts are not damaged.
- Before you install the power source on site, see the requirements for the mains cable type and fuse rating.

Distribution network

-  *This Class A equipment is not intended for use in residential locations where the electrical power is provided by the public low-voltage supply system. There can be potential difficulties in ensuring electromagnetic compatibility in those locations, due to conducted as well as radiated radio-frequency disturbances. However, Minarc T 223 DC complies with IEC 61000-3-12 and can also be connected to public low-voltage systems.*

2.1 INSTALLING EQUIPMENT ON CART (OPTIONAL)

Minarc T 223 DC has one transport unit option: MST 400.

 *The maximum recommended size of the gas bottle to be installed on the cart is 20 liters.*

Tools needed:



To install the power source on the MST 400 cart:

1. Install the power source fixing bracket (for instructions on installing the gas bottle, refer to "Installing gas bottle and testing gas flow" on page 15).

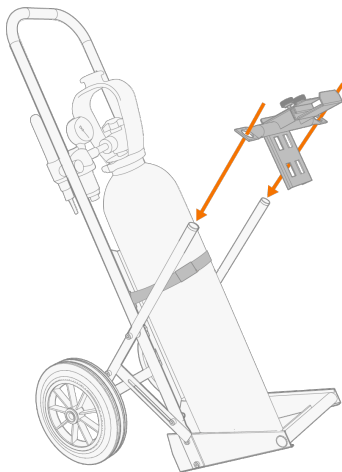

2. Mount the power source to the fixing bracket. Slide the fixing bracket so that it tightens onto the lifting handle of the power source. Fix the power source to the cart with the two fixing screws.

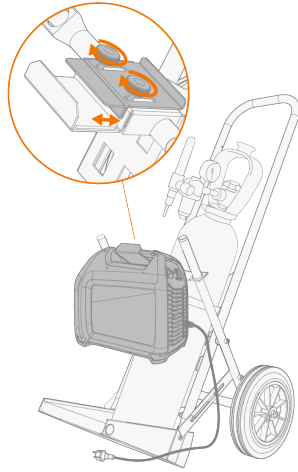

For lifting the equipment, refer to "Lifting equipment" on page 37.

2.2 CONNECTING TIG WELDING TORCH

Minarc T 223 DC is designed to be used with the Kemppi Flexlite TX TIG welding torches. For more information, refer to [Kemppi Userdoc](#).

1. Connect the control cable (1) to the control cable connector in the power source.
2. Connect the welding cable (2) to the TIG welding cable connector in the power source. Secure by turning the connector clockwise.
3. Connect the earth return cable to the positive (+) DIX connector.

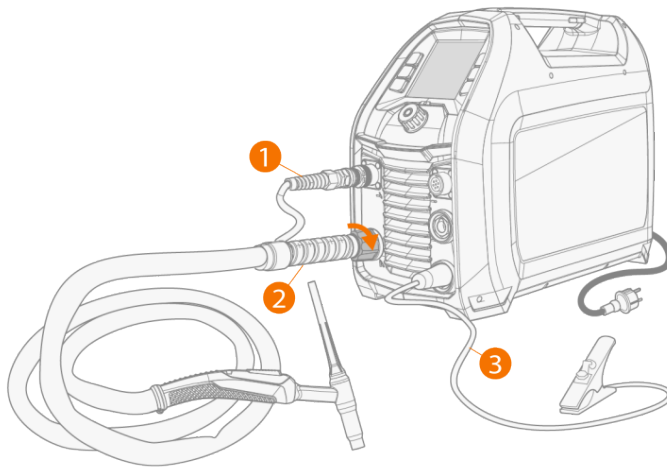

4. Check the gas flow. For more information, refer to "Installing gas bottle and testing gas flow" on page 15.

2.3 CONNECTING MMA ELECTRODE HOLDER

1. Connect the MMA electrode holder to the positive (+) DIX connector and tighten it.
2. Connect the earth return cable to the negative (-) DIX connector.

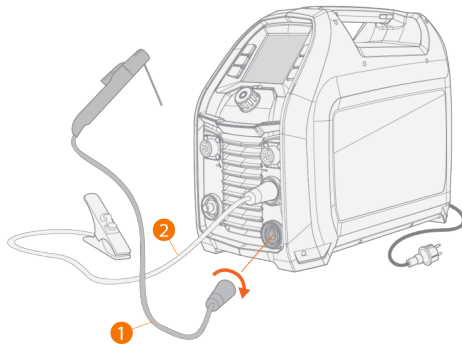

i *The cables can also be connected the other way round, depending on the electrode and welding application.*

2.4 INSTALLING REMOTE CONTROL

Remote controls are optional. Connect the remote control to the Minarc T 223 DC power source or the Flexlite TX welding torch. To enable remote operation, set the remote mode in the control panel (refer to "Minarc T 223 DC control panels" on page 20).

Minarc T 223 DC is compatible with the following Kemppi remote controls:

- R10 hand remote control
- FR41 foot pedal remote control
- TXR10 torch remote control
- TXR20 torch remote control (rocker switch).



For information on installing a torch remote control, refer to [Kemppi Userdoc](#).

Remote control R10/FR41

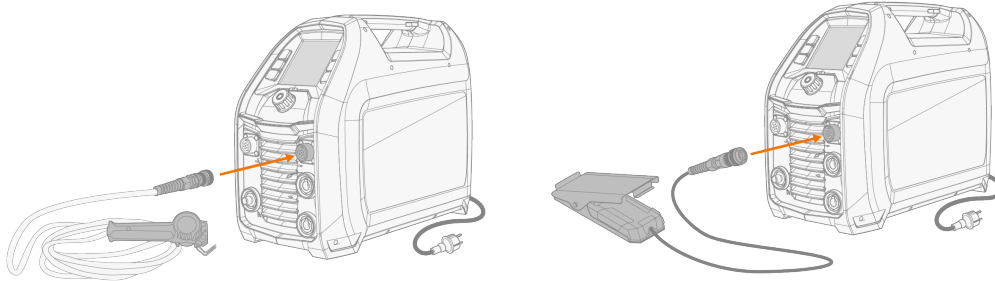
1. Connect the remote control cable to the power source.



2.5 INSTALLING GAS BOTTLE AND TESTING GAS FLOW

-  *Handle gas bottles with care. There is a risk of injury if the gas bottle or the bottle valve is damaged!*
-  *Always secure the gas bottle properly in an upright position to a special holder on the wall or on the welding equipment cart. Always keep the gas bottle valve closed when not welding.*
-  *- If a cart with a gas bottle rack is used, install the gas bottle on the cart first, then make the connections.*
 - The maximum recommended size of the gas bottle to be installed on the cart is 20 liters.*
 - Install the welding torch to the power source before installing and testing the gas bottle.*

Contact your local Kemppi dealer for choosing the gas and the equipment.

1. Without gas bottle cart: Place the gas bottle in a suitable, secure location.
2. With gas bottle cart: Move the gas bottle on the transport unit's gas bottle rack.

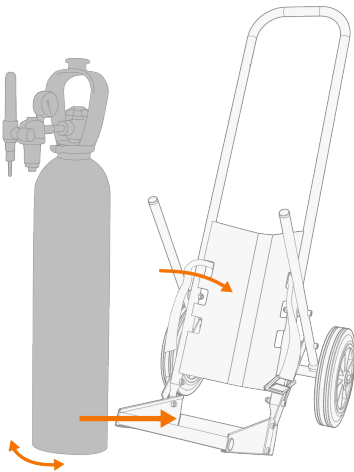

3. Secure the gas bottle in place with the strap provided.

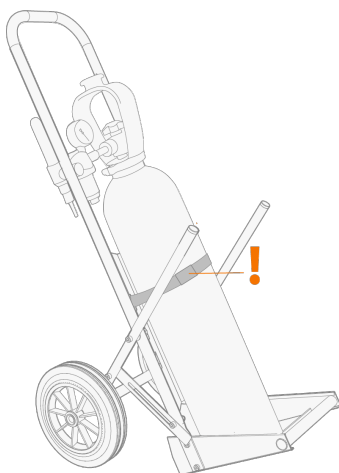

4. If not already, connect the welding torch to the power source (refer to "Connecting TIG welding torch" on page 12).
5. Connect the gas hose to the power source.

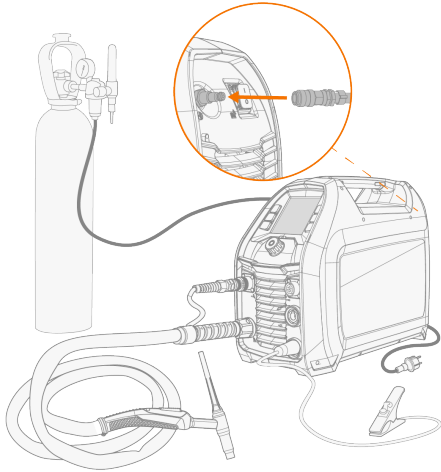

6. Open the gas bottle valve.
 7. Start gas test by pressing the control panels' gas test button or by long-pressing the control panel's control knob button in the main view.
- i** *By default, the gas test time is 20 s. During the gas test, you can adjust the time (between 0 ... 60 s, step 1 s) by turning the control knob.*
- i** *You can end the gas test by pressing the control knob button.*
8. Check and adjust the gas flow. Use an external flow meter and regulator for measuring and adjustment.

2.6 ATTACHING CARRYING STRAP

The carrying strap is designed for manually moving the welding device in the workplace.



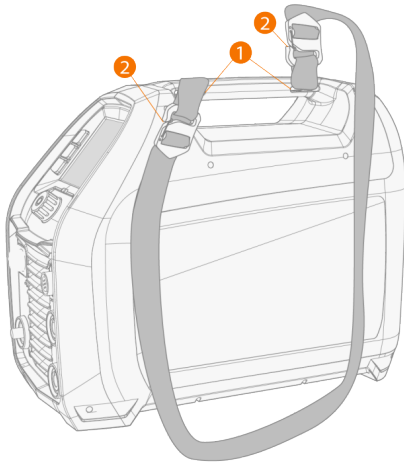

 *Always turn off the welding device before carrying it by the carrying strap.*

1. Thread the ends of the carrying strap through the slots in the lifting handle of the power source.
2. Attach the ends of the strap to the buckles with the spring locking mechanism.



3. OPERATION

Before using the equipment, ensure that all the necessary installation actions have been completed according to your equipment setup and instructions.

-  *Welding is forbidden in places where there is an immediate fire or explosion hazard!*
-  *The welding device is intended for use in environments where the risk of electric shock is not increased.*
-  *Check that there is enough space (> 15 cm) for cooling air circulation in the machine vicinity.*
-  *If the welding equipment is left unused for a longer period, disconnect the mains plug from the mains.*
-  *Always check before use that shielding gas hose, earth return cable and clamp and mains cable are in serviceable condition. Ensure that the connectors are correctly fastened. Loose connectors can impair welding performance and damage connectors.*

3.1 PREPARING WELDING SYSTEM FOR USE

Before starting the use of the welding equipment:

- Ensure the installation has been completed
- Switch the power source on
- Connect the earth return cable.

Turning on power source

To turn on the power source, switch the power source main switch to 1.

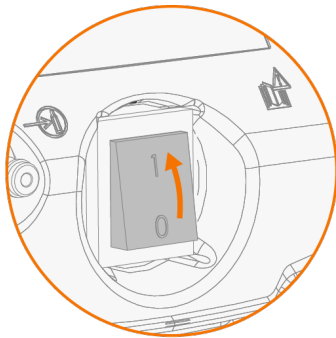

Use the main switch to start and shut down the welding equipment. Do not use the mains plug as a switch.

 *If the machine is left unused for a longer period, detach the mains plug to disconnect it from the mains.*

Connecting earth return cable

 *Keep the work piece connected to earth to reduce the risk of injury to users or damage to electrical equipment.*

Attach the earth return cable clamp on the work piece.

Ensure that the contact surface is clean of metal oxide and paint and that the clamp is firmly secured.

Selecting process

To select the process (TIG/MMA), refer to "Minarc T 223 DC control panels" on the next page.

3.2 MINARC T 223 DC CONTROL PANELS

This section describes the controls and features of the Minarc T 223 DC control panels. The standard power source model has the standard control panel and the MLP power source model has the MLP control panel (for more information, refer to "Equipment description" on page 5).

You can access different parameter adjustments and setups by pressing the physical buttons (2-7 in the figure below). Once the adjustments have been made, exit by pressing the same button again or by pressing another button.

Standard control panel

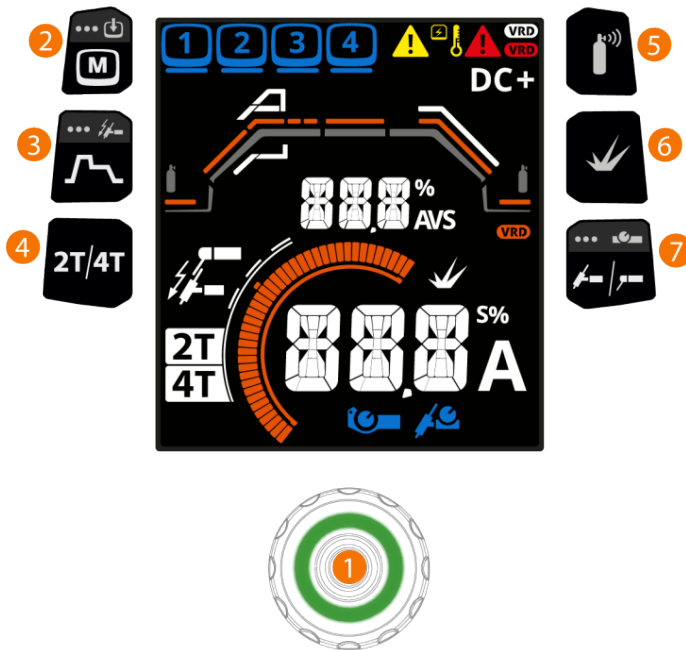

1. Control knob
 - >> Adjustment and selection (for more information, refer to "Main view" on page 23)
2. Memory channels button
 - >> Short press: Changes memory channel
 - >> Long press: Saves parameters to memory channel
3. Welding parameters and TIG HF ignition button
 - >> Short press: Welding parameter adjustment
 - >> Long press: Toggles between TIG HF ignition ON / OFF
4. Trigger logic button (TIG)
 - >> Short press: Toggles between 2T and 4T trigger logic functions
5. Gas test
 - >> Short press: Toggles between gas test ON/OFF
6. MMA arc force button
 - >> Short press: MMA arc force adjustment
7. Process and remote control button
 - >> Short press: Toggles between TIG/MMA processes
 - >> Long press: Toggles between remote control modes (hand/foot pedal remote, torch remote and remote control OFF). A remote control must be connected to the welding device or welding torch.

MLP control panel

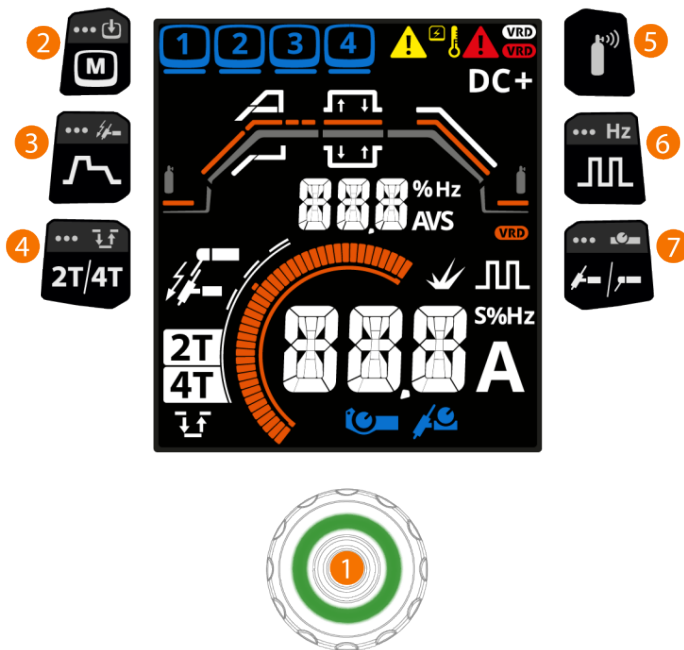













1. Control knob
 - >> Adjustment and selection (for more information, refer to "Main view" on page 23)
2. Memory channels button
 - >> Short press: Changes memory channel
 - >> Long press: Saves parameters to memory channel
3. Welding parameters and TIG HF ignition button
 - >> Short press: Welding parameter adjustment
 - >> Long press: Toggles between TIG HF ignition ON / OFF
4. Trigger logic button (TIG)
 - >> Short press: Toggles between 2T and 4T trigger logic functions
 - >> Long press in 2T: Sets 4T and Minilog on
 - >> Long press in 4T: Sets Minilog on
 - >> Short press when Minilog is on: Sets Minilog off and changes trigger logic to 2T
 - >> Long press when Minilog is on: Sets Minilog off but trigger logic stays in 4T
5. Gas test
 - >> Short press: Toggles between gas test ON/OFF
6. Pulse TIG button
 - >> Short press: Toggles between pulse TIG welding ON / OFF
 - >> Long press when pulse TIG is on: Pulse frequency adjustment
7. Process and remote control button
 - >> Short press: Toggles between TIG/MMA processes
 - >> Long press: Toggles between remote control modes (hand/foot pedal remote, torch remote and remote control OFF). A remote control must be connected to the welding device or welding torch.

Factory reset

To reset the device to factory settings, long-press the Trigger logic button (4) and the Process and remote control button (7) simultaneously.

Symbols

Symbol	Description
	Yellow: Warning Red: Error
	Power source error
	High temperature indicator (overheating)
	VRD (Voltage Reduction Device): White VRD symbol is on = VRD is on Red VRD symbol is blinking = There is a problem with VRD
	TIG welding process
	Pulse TIG process (MLP control panel only)
	Pulse TIG frequency (MLP control panel only)
	MMA welding process
	Minilog (MLP control panel only)
	HF ignition
	Arc force (MMA)
AUT	Auto
Err	Error
4TL	4T LOG
SA	Search arc
TA	Tail arc
	Remote control (hand / foot pedal)
	Torch remote control

 After each weld, a weld summary ([Weld data](#)) is displayed for 5 s.

To update the control panel software, contact your local Kemppi service.

3.2.1 MAIN VIEW

Main view is the main welding view. The content displayed depends on the welding process and features and functions used.

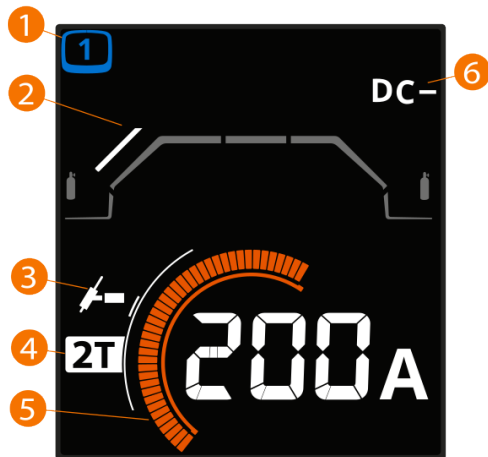

1. Active memory channel
2. Applied parameters and functions (for more information, refer to "Welding parameters" below)
3. Active welding process
4. Applied trigger logic function
5. Welding current
6. Current mode.

Control knob functions in the main view:

- **TIG:**
 - >> Welding current adjustment
 - >> Long press of the control knob button starts gas test (during the gas test, you can adjust the gas test time by turning the control knob)
- **MMA:**
 - >> Welding current adjustment
 - >> Arc force adjustment

3.2.2 WELDING PARAMETERS

The Welding parameters view includes a start and stop curve for visualizing and adjusting the parameters for a weld. You can access the welding parameters by pressing the control panel's Welding parameters and TIG HF ignition button (refer to "Minarc T 223 DC control panels" on page 20).

The white line indicates that the parameter is on. The orange line indicates that the parameter value is currently adjustable. If the Auto value of a parameter is used, its numerical value is displayed below the start and stop curve.

 *Many of the welding parameters are welding process specific and are visible and available for adjustment accordingly.*

The parameters are explained in the 'Welding parameters' table.

Standard control panel

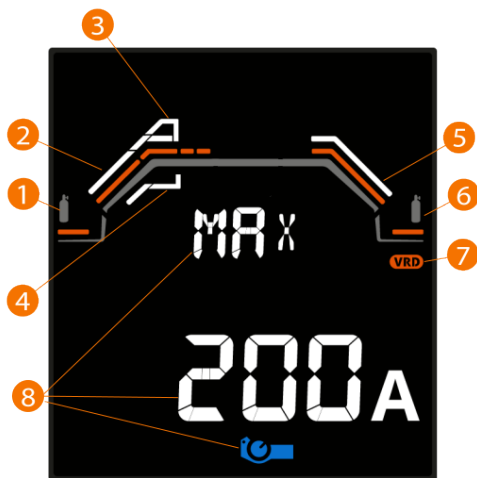

1. Pre gas
2. Upslope
3. Hot start, positive values
4. Hot start, negative values
5. Downslope
6. Post gas
7. VRD
8. Min/Max current limit for remote control

MLP control panel

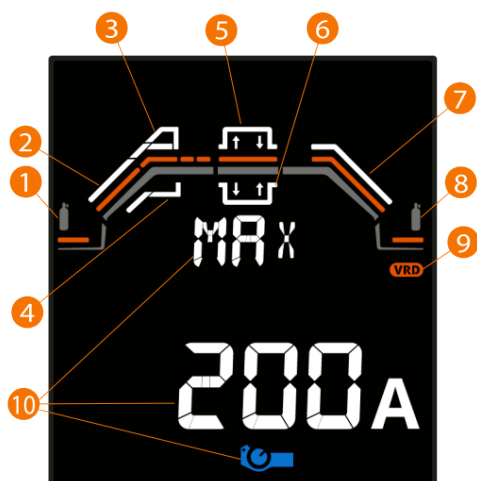

1. Pre gas
2. Upslope
3. Hot start, positive values
4. Hot start, negative values
5. Minilog, positive values

6. Minilog, negative values
7. Downslope
8. Post gas
9. VRD
10. Min/Max current limit for remote control

4T LOG parameters (in both standard and MLP control panels)

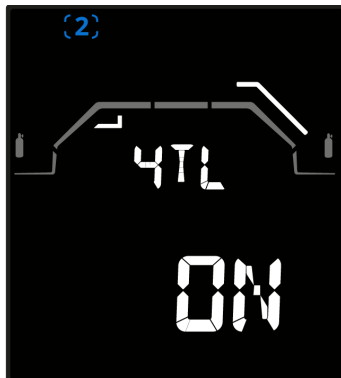

4TL = 4T LOG

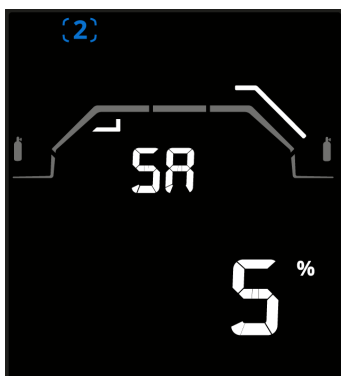

SA = Search arc

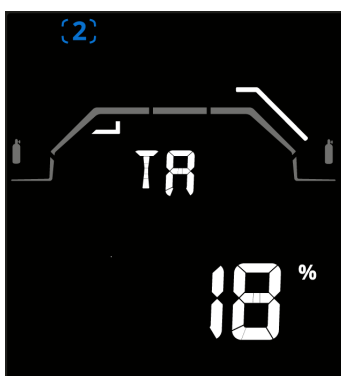

TA = Tail arc

Adjusting welding parameters

1. Turn the control knob so that the orange line appears at the desired welding parameter (here the Upslope parameter is used as an example).



2. Press the control knob button to select the welding parameter for adjustment.

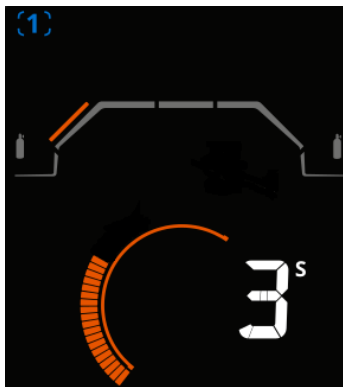

3. Turn the control knob to adjust the welding parameter value.
4. Confirm the new value / selection by pressing the control knob button.

Tip: When a parameter value is adjustable, you can select the parameter's default value by long-pressing the control knob button. This works for all parameters except VRD.

Welding parameters

TIG welding parameters

The parameters listed here are available for adjustment with the TIG welding process.

Parameter	Parameter value	Description
Pre gas	0.0 ... 10 s, Auto, step 0.1 Default = Auto	Pre gas is a welding function that starts the shielding gas flow before the arc ignites. This ensures that the metal does not come into contact with air at the start of the weld. Used for all metals, but especially for stainless steel, aluminum and titanium. When Auto is selected the pre gas is determined automatically according to the welding current.
Upslope	0.0 ... 5 s, step 0.1 Default = 0 s	Upslope is a welding function that determines the time, during which the welding current gradually increases to the desired welding current level at the start of the weld.
Hot start	ON/OFF Default = OFF	Welding function that uses higher or lower welding current at the start of the weld. After the Hot start period the current changes to normal welding current level. This facilitates the start of the weld especially with aluminum materials. The Hot start time is used only in 2T trigger mode.
- Hot start level	-80 ... +100 %, step 1 Default = +30 %	
- Hot start time	0.1 ... 9.9 s, step 0.1 Default = 1.2 s	
Minilog level (MLP control panel only)	-99 % ... 125 %, step 1 Default = -80 %	Minilog is a TIG welding function, which allows using the torch switch to change between the welding current and Minilog current which can be lower or higher than the welding current. For more information, refer to "Trigger logic functions (TIG)" on page 32. For information on setting Minilog to ON, refer to "Minarc T 223 DC control panels" on page 20.

4T LOG (4TL)	ON/OFF Default = OFF	4T LOG is a TIG welding function, which allows using the welding torch trigger to start and stop welding and change between current levels.
- Search arc (SA)	0 % (OFF) / 5 % ... 90 %, step 1 % Default = 0 %	Search arc allows using lower current for a brief period at the start of the weld. This enables precise start of welding.
- Tail arc (TA)	0 % (OFF) / 5 % ... 90 %, step 1 % Default = 0 %	Tail arc allows using lower current for a brief period at the end of the weld. This reduces welding defects caused by crater formation at the end of welding.
Downslope	0.0 ... 1.5 s, step 0.1 Default = 0.1 s	Downslope is a welding function that determines the time during which the welding current gradually decreases to the end current level.
Post gas	0.0 ... 9.9 s, Auto, step 0.1 Default = Auto	Post gas is a welding function that continues the shielding gas flow after the arc has extinguished. This ensures that the hot weld does not come into contact with air after the arc is extinguished, protecting the weld and also the electrode. Used for all metals. Especially stainless steel and titanium require longer post gas times. When Auto is selected the post gas is determined automatically according to the welding current.
Remote control min	Min = Current limit minimum Max = Current limit maximum	Minimum and maximum welding current limits for remote control. These parameters are used to limit the current adjustment range for analog remote controls. The current limits do not apply to the TXR20 rocker switch remote control.
Remote control max		

MMA welding parameters

The parameters listed here are available for adjustment with the MMA welding process.

Parameter	Parameter value	Description
Hot start level	-10 ... +10, step 1 Default = 0	Welding function that uses higher or lower welding current at the start of the weld. After the Hot start period the current changes to normal welding current level. This facilitates the start of the weld especially with aluminum materials.

VRD	ON/OFF Default = OFF (In AU power source models VRD is locked ON)	Voltage reduction device (VRD) reduces the open-circuit voltage to maintain below a certain voltage value. This parameter applies to all memory channels.
Remote control min.	Min = Current limit minimum Max = Current limit maximum	These parameters are used to limit the current adjustment range for analog remote controls. The current limits do not apply to the TXR20 rocker switch remote control.
Remote control max.		

3.2.3 MEMORY CHANNELS

The TIG and MMA processes have 4 memory channels each. You can access the memory channels by pressing the control panel's Memory channels button (refer to "Minarc T 223 DC control panels" on page 20).

Saving changes to memory channel

1. Adjust a parameter value.
2. The channel number framed by a dashed line indicates that the set parameters are different from the ones currently saved on the active memory channel:



3. Long-press the memory channels button.
4. Save the changes to the active memory channel by pressing the control knob button or select another channel by turning the control knob and pressing the control knob button.

3.2.4 WELD DATA

After each weld, a weld summary is displayed for 5 seconds.

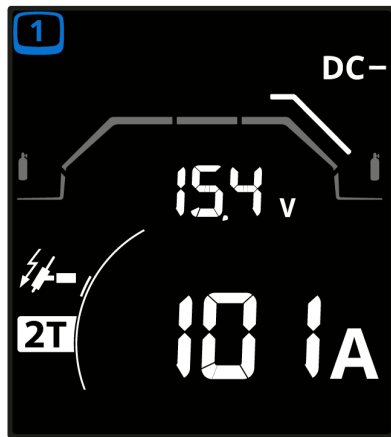

3.3 ADDITIONAL GUIDANCE TO FUNCTIONS AND FEATURES

This section summarizes some of the Minarc T 223 DC functions and features and how to use them.

3.3.1 TIG PROCESSES AND CURRENT MODES

DC- TIG

DC- (direct current, negative polarity) TIG is a TIG current mode where the polarity of the electrode is negative throughout the welding process. Negative polarity allows high penetration.

Pulse TIG (Minarc T 223 DC MLP model only)



Pulse TIG is a welding process where the current is pulsed between the base current and the pulse current. Pulse TIG is used for optimizing arc characteristics.

The user can adjust the pulse frequency, other parameters are defined by the active welding program. Pulse frequency determines how many pulse cycles are created per second (Hz). The pulse frequency values are listed below. The default value is 1.0 Hz.

- 0.1 ... 10 Hz, step 0.1
- 10 ... 100 Hz, step 1 (note that a value in the range 10 ... 50 Hz is eye-straining)
- 100 ... 300 Hz, step 10

>> To take pulse TIG into use, press the [pulse TIG](#) button in the MLP control panel.

>> To adjust the pulse frequency, long-press the pulse TIG button.

3.3.2 IGNITION MODES IN TIG WELDING

TIG ignition modes determine the way in which the welding arc is ignited. Two ignition modes are available in TIG welding: Lift TIG ignition and High Frequency (HF) ignition.

High Frequency (HF) ignition

In HF ignition, a press on the torch trigger produces a high voltage pulse that creates a spark to ignite the arc.

Lift TIG ignition

In Lift TIG ignition you briefly touch the work piece with the electrode, then press the trigger and lift the electrode to a small distance from the work piece. Also known as "Touch ignition" or "Contact ignition".

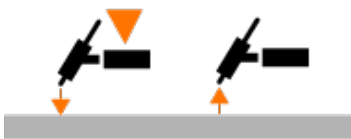

3.3.3 TRIGGER LOGIC FUNCTIONS (TIG)

This section describes the trigger logic functions available for the TIG welding process.

 You cannot change trigger logic during welding.

2T (default)

In 2T welding, pressing the trigger ignites the arc. Releasing the trigger switches the arc off.



4T

In 4T welding, pressing the trigger starts the pre gas, and releasing the trigger ignites the arc. Pressing the trigger again switches the arc off. Releasing the trigger ends the post gas.



If Hot start is used with 4T, pressing the trigger starts the pre gas for a predefined duration, after which the arc ignites automatically and the current raises to the Hot start level. The current is lowered to the normal welding current level once the trigger is released. If the trigger is released before the start sequence reaches the Hot start phase, the arc is ignited without Hot start.

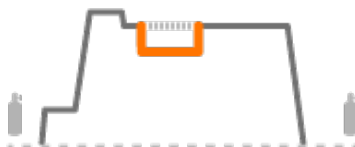

Minilog (Minarc T 223 DC MLP model only)

TIG welding function, which allows using the torch switch to change between the welding current and Minilog current which can be lower or higher than the welding current. Short press switches to the Minilog current and another short press returns to the welding current. Long-press switches the arc off and starts the post gas.



The user presets the parameters. Welding over tack welds is one application. It also functions as a "pause current" when the welding position changes, for example. Minilog can be used only with TIG 4T and 4T LOG trigger logics.

- >> To take the Minilog trigger logic into use, long-press control panel's trigger logic button in 2T or 4T mode.
- >> Adjust the Minilog level in the [welding parameters](#).

-  You can set Minilog to OFF and set the trigger logic to 2T by pressing the trigger logic button in 4T Minilog mode.
-  You can set Minilog to OFF (and stay in 4T trigger logic mode) by long-pressing the trigger logic button in 4T Minilog mode.



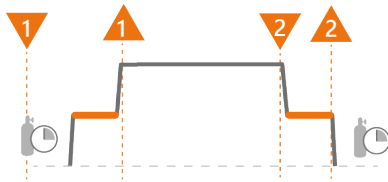

4T LOG

Pressing and holding the trigger starts the pre gas for a predefined duration, after which the arc ignites automatically and the current raises to the Search arc level. After the trigger is released, the current raises to the normal welding current level. When the trigger is pressed again, the current decreases to the Tail arc level. Releasing the trigger switches the arc off and starts the post gas for a predefined duration.



If Hot start is used with 4T LOG, releasing the trigger at the Search arc level raises the current to the Hot start level for the predefined duration. The current is then lowered to the normal welding current level.

Symbols:

	Function
	Set duration
	Trigger press (down)
	Trigger release (up)
	Pre gas / post gas

3.3.4 MMA FUNCTIONS AND FEATURES

MMA antifreeze

MMA antifreeze function automatically decreases the welding current significantly when the electrode is touching the workpiece. The function can be used to prevent the MMA electrode from getting too hot when it is in contact with the workpiece. The MMA antifreeze function is always on and does not need to be adjusted.

MMA arc force

MMA arc force adjusts short circuit dynamics (roughness) of MMA welding by changing, for example, current levels.

The adjustment range is -10...+10, the step is 1, and the default is 0.

MMA current modes

The available current modes for MMA welding are DC- and DC+. Select the current mode according to the electrode and the welding application.

-  *The MMA current mode is not selectable via the control panel, it is determined by the welding cable connections (refer to "Connecting MMA electrode holder" on page 13).*

3.4 USING REMOTE CONTROL

To enable remote control operation, select the remote control mode by long-pressing the control panel's Process and remote control button (refer to "Minarc T 223 DC control panels" on page 20).

 You can set the minimum and maximum current limits for the remote controls in [Welding parameters](#).
The current limits do not apply to the TXR20 rocker switch remote control.

The hand or foot pedal remote control can be used simultaneously with the TXR20 rocker switch remote control.

R10 hand remote control

To adjust current, turn the knob on the remote control.

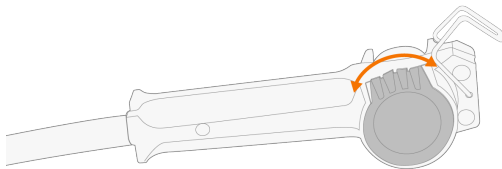

Tip: The remote control comes equipped with a handy clip for hanging the remote onto your belt.

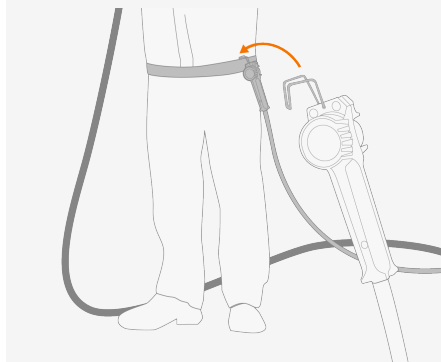

When the R10 remote control is used, current adjustment from the control panel is not possible.

FR41 foot pedal remote control

To adjust current, press the pedal.

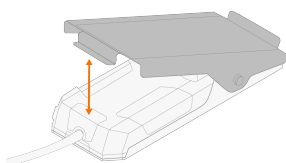

When the FR41 remote control is used, current adjustment from the control panel is not possible.

TXR10 torch remote control

To adjust current, roll the roller switch.

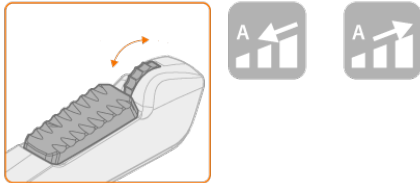

When the TXR10 remote control is used, current adjustment from the control panel is not possible.

TXR20 rocker switch remote control

To adjust current, pull/push the rocker switch.

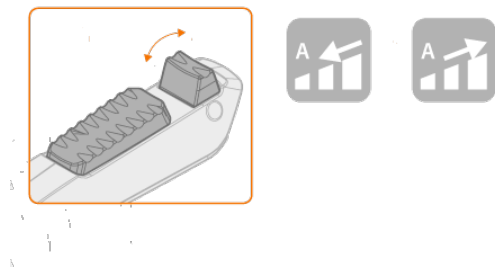

When the TXR20 torch remote control is used, the remote control symbol is not displayed and current can be adjusted on the control panel. The current values affect the resolution of the remote control adjustment as follows:

- step is 1 A when the current is below 50 A
- step is 2 A when the current is 50 ... 150 A
- step is 3 A with minus button and 2 A with plus button when the current is over 150 A.

3.5 LIFTING EQUIPMENT

 Do not attempt to lift the device with a hoist when the device is installed on a cart.

 Do not attempt to lift the device with a hoist from the carrying strap.

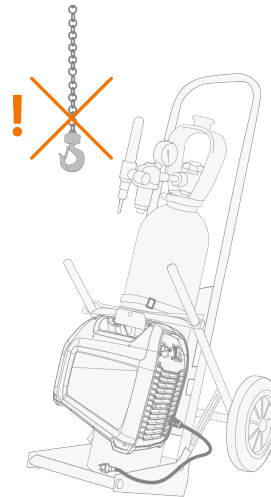
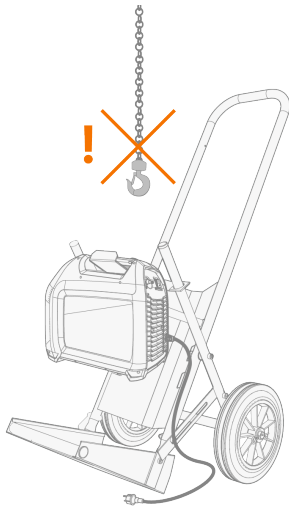

The power source's lifting handle can be used for mechanical lifting (for moving only, not for hanging) when the device is not mounted on a cart.

Connect the hoist hook to the handle.

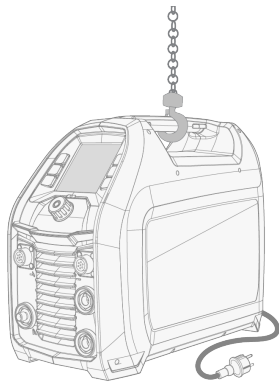

3.6 TROUBLESHOOTING

i *The problems listed and the possible causes are not definitive, but suggest some typical situations that may turn up during normal use of the welding system.*

Welding device:

Problem	Recommended actions
The welding device does not power up	Check that the mains cable is plugged in properly.
	Check that the mains switch of the power source is at the ON position.
	Check that the mains power distribution is on.
	Check the mains fuse and/or the circuit breaker.
	Check that the earth return cable is connected.
The welding device stops working	Check that none of the cables is loose.
	The power source may have overheated. Wait for it to cool down and see that the cooling fans work properly and the air flow is unobstructed.

Weld quality:

Problem	Recommended actions
Dirty and/or poor quality weld	Check that the shielding gas has not run out.
	Check that the shielding gas flow is unobstructed.
	Check that the gas type is correct for the application.
	Check that the welding procedure is correct for the application.
Varying welding performance	Check that the welding torch is physically intact and the nozzle is clear of any obstructions.
	Check that the welding torch is not overheating.
	Check that the earth return clamp is properly attached to a clean surface of the workpiece.
	Check that the earth return clamp is properly attached to a clean surface of the workpiece.
High spatter volume	Check the welding parameter values and welding procedure.
	Check the gas type and flow.
	Check the polarity of the torch/electrode.

"Error codes " on the next page

3.7 ERROR CODES

In error situations, the control panel displays 'Err' and the number of the error. This section lists the errors, possible causes and proposed actions to fix the issue.

Error		
Code	Possible cause	Proposed action
1	Power source calibration has been lost.	Restart the power source. If problem persists, contact Kemppi service.
2	Voltage in mains network is too low.	Restart the power source. If problem persists, contact Kemppi service.
3	Voltage in mains network is too high.	Restart the power source. If problem persists, contact Kemppi service.
4	Too long welding session with high power.	Do not shut down, let the fans cool the machine. If fans are not running, contact Kemppi service
5	Power source contains an inoperative 24V power supply unit.	Restart the power source. If problem persists, contact Kemppi service.
12	Plus and minus cables are connected together.	Check the connections of welding cable and earth return cable.
14	Too long welding session with high power or high ambient temperature.	Do not shut down, let the fans cool the machine. If fans are not running, contact Kemppi service.
20	Cooling capacity is reduced in the power source.	Clean the filters and clear any dirt from the cooling channel. Check that the cooling fans are running. If not, contact Kemppi service.
40	Open circuit voltage exceeds the VRD limit.	Restart the power source. If problem persists, contact Kemppi service.
81	Welding program data has been lost.	Restart the power source. If problem persists, contact Kemppi service.

4. MAINTENANCE





4.1 DAILY, PERIODIC AND ANNUAL MAINTENANCE

When considering and planning routine maintenance, consider the operating frequency of the welding system and the working environment.

Correct operation of the welding machine, regular maintenance, and the use of original Kemppi spare parts and consumables help you avoid unnecessary downtime and equipment failure, while also maximizing the equipment's service life.

Use pre-mixed coolant solution in the cooling unit. The mixing ratio should be 20...50% as standard. Use only ethylene or propylene glycol mixture intended for welding cooling systems, for example Kemppi cooling liquid. Do not add water to the pre-mixed coolant solution. Do not use automotive cooling solutions or ethanol-based mixtures.

For repairs, find your closest Kemppi service workshop at www.kemppi.com or contact your dealer.

-  *Only an authorized electrician is allowed to carry out electrical work.*
-  *Only qualified service personnel is allowed to carry out periodic and annual maintenance.*
-  *Disconnect the power source from the mains before handling electrical cables and connectors.*
-  *Do not use pressure washing devices.*
-  *Where applicable, use the correct tension torque when fastening loose parts.*

Daily maintenance

Welding equipment's daily maintenance:

- Check that all covers and components are intact.
- Check all the cables, hoses and connectors. Do not use them if they are damaged.
- Ensure that the connectors are correctly fastened. Loose connectors can impair welding performance and damage connectors.

Cooling unit's daily maintenance (in addition):

- Check the cooling liquid level. Add cooling liquid if needed. Note: Use the correct coolant solution (see above).
- Check the cooling unit surroundings for cooling liquid leakages. If there are signs of significant leakage, contact Kemppi service.
- Check and test the cooling liquid pump operation by circulating the cooling liquid.

Weekly maintenance

Welding equipment's weekly maintenance:

- Clean the outside parts of the units from dust and dirt, for example, with a soft brush and vacuum cleaner.
- Clean the ventilation grills. Do not use compressed air, there is a risk that the dirt will compact even more tightly into the gaps of the cooling profiles.

Periodic maintenance

Welding equipment's periodic maintenance, every 1–6 months:

- Check the electrical connectors of the equipment at least every 6 months. Clean oxidized parts and tighten loose connectors.
- Update the welding system to the latest firmware and software versions, as applicable.

Cooling unit's periodic maintenance, every 1–6 months (in addition):

- Check the cooling liquid quality at least once a month. Ensure that the liquid is clear and free of any visible impurities.
- Replace the cooling liquid every 6 months. Note: Use the correct coolant solution (see above).

Annual maintenance

The annual maintenance must be carried out by an authorized Kemppi service workshop. Kemppi service workshops complete the welding system maintenance according to your Kemppi service agreement. Find your closest service workshop at www.kemppi.com.

Welding equipment's annual maintenance program includes:

- Cleaning the equipment.
- Maintenance of the welding tools.
- Checking the connectors and switches.
- Checking all electrical connections.
- Checking the power source mains cable and plug.
- Repairing defective parts and replacing defective components.
- Maintenance test.
- Testing the operation and calibrating the performance values when needed.
- Updating the welding system to the latest firmware and software versions, and installing new welding software.
- If a cooling unit is used: Checking and cleaning the cooling liquid pump. The pump is dismantled and cleaned thoroughly, and if there has been any leakage in the pump's axle seal point, the axle seal is replaced. The axle seal is subject to wear and may need replacement periodically to maintain proper sealing.

For Kemppi welding torch maintenance, refer to your welding torch's instructions (available also at user-doc.kemppi.com).

4.2 DISPOSAL



Do not dispose of any electrical equipment with normal waste!

In observance of WEEE Directive 2012/19/EU on waste of electrical and electronic equipment and European Directive 2011/65/EU on the restriction of the use of certain hazardous substances in electrical and electronic equipment, and their implementation in accordance with national law, electrical equipment that has reached the end of its life must be collected separately and taken to an appropriate environmentally responsible recycling facility. The owner of the equipment is obliged to deliver a decommissioned unit to a regional collection center, as per the instructions of local authorities or a Kempfi representative. By applying these European Directives you improve the environment and human health.

For more information:



5. TECHNICAL DATA

Technical data:

- For Minarc T 223 DC power source technical data, refer to "Minarc T 223 DC power source" on the next page.

Additional information:

- For TIG guide tables, refer to "TIG guide table" on page 48.
- For ordering information, refer to "Minarc T 223 DC ordering info" on page 49.

5.1 MINARC T 223 DC POWER SOURCE

 The technical data in the tables apply to both standard and MLP device models.

Minarc T 223 DC GM and Minarc T 223 DC MLP GM

Minarc T 223 DC GM		
Feature		Value
Mains connection voltage		220...240 V \pm 10 %
Mains connection voltage	MV low range	110...120 V \pm 10 %
Mains connection phases		1~50/60 Hz
Mains connection cable type		3G, H07RN-F
Mains connection cable size		2.5 mm ²
Rated maximum input power [S_{1max}]		5.5 kVA
Mains fuse		16 A
Mains fuse	@MV low range	16 A
Idle power		10 W
No-load voltage (MMA) [U_f]		95 V
No-load voltage (MMA) VRD [$U_f VRD$]		23 V
No-load voltage (MMA/TIG) [U_0]		107 V
Open circuit voltage (MMA)		95 V
Effective supply current [I_{1eff}]		16 A
Effective supply current [I_{1eff}]	@MV low range	15 A
Maximum supply current [I_{1max}]		25 A
Maximum supply current [I_{1max}]	@MV low range	23 A
Output, duty cycle % at rated max current, TIG		20 %
Output at +40 °C, rated max current, TIG		220 A
Output at +40 °C, 60% TIG		170 A
Output at +40 °C, 100% TIG		140 A
Output, duty cycle % at rated max current, TIG	@MV low range	20 %
Output at +40 °C, rated max current, TIG	@MV low range	130 A
Output at +40 °C, 60% TIG	@MV low range	110 A
Output at +40 °C, 100% TIG	@MV low range	90 A
Output, duty cycle % at rated max current, MMA		25 %
Output at +40 °C, rated max current, MMA		170 A
Output at +40 °C, 60% MMA		140 A
Output at +40 °C, 100% MMA		120 A
Output, duty cycle % at rated max current, MMA	@MV low range	20 %
Output at +40 °C, rated max current, MMA	@MV low range	75 A

Output at +40 °C, 60% MMA	@MV low range	70 A
Output at +40 °C, 100% MMA	@MV low range	60 A
Output range, TIG welding current/voltage		5 A / 8 V ... 220 A / 20 V
Output range, MMA welding current/voltage		15 A / 15 V ... 170 A / 34 V
Output range, TIG welding current/voltage	@MV low range	5 A / 8 V ... 130 A / 16 V
Output range, MMA welding current/voltage	@MV low range	15 A / 15 V ... 75 A / 31 V
Power factor at rated maximum current	λ	1
Efficiency at rated maximum current	η	85 %
Welding connection type		R1/4
Arc striking voltage		11 kV
Stick electrode diameter range		1.6...4 mm
Wired communication type		Analog
Operating temperature range		-20...40 °C
Storage temperature range		-40...60 °C
Recommended minimum generator power [S_{gen}]		8 kVA
EMC class		A
Degree of protection		IP23
External dimensions	$L \times W \times H$	461 x 202 x 367 mm
Weight without accessories		9.6 kg
Standards		EN IEC 60974-1, -3, -10, IEC 61000-3-12

Minarc T 223 DC GM AU and Minarc T 223 DC MLP GM AU (VRD locked on)

Minarc T 223 DC GM AU		
Feature		Value
Mains connection voltage		230...240 V \pm 10 %
Mains connection voltage	MV low range	110...120 V \pm 10 %
Mains connection phases		1~50/60 Hz
Mains connection cable type		3G, H07RN-F
Mains connection cable size		1.5 mm ²
Rated maximum input power [S_{1max}]		5.5 kVA
Mains fuse		15 A
Mains fuse	@MV low range	15 A
Idle power		10 W
No-load voltage (MMA) [U_f]		23 V
No-load voltage (MMA) VRD [U_fVRD]		23 V
No-load voltage (MMA/TIG) [U_0]		107 V
Open circuit voltage (MMA)		23 V
Effective supply current [I_{1eff}]		15 A
Effective supply current [I_{1eff}]	@MV low range	15 A

Maximum supply current [I_{1max}]		24 A
Maximum supply current [I_{1max}]	@MV low range	23 A
Output, duty cycle % at rated max current, TIG		20 %
Output at +40 °C, rated max current, TIG		220 A
Output at +40 °C, 60% TIG		170 A
Output at +40 °C, 100% TIG		140 A
Output, duty cycle % at rated max current, TIG	@MV low range	20 %
Output at +40 °C, rated max current, TIG	@MV low range	130 A
Output at +40 °C, 60% TIG	@MV low range	110 A
Output at +40 °C, 100% TIG	@MV low range	90 A
Output, duty cycle % at rated max current, MMA		25 %
Output at +40 °C, rated max current, MMA		170 A
Output at +40 °C, 60% MMA		140 A
Output at +40 °C, 100% MMA		120 A
Output, duty cycle % at rated max current, MMA	@MV low range	20 %
Output at +40 °C, rated max current, MMA	@MV low range	75 A
Output at +40 °C, 60% MMA	@MV low range	70 A
Output at +40 °C, 100% MMA	@MV low range	60 A
Output range, TIG welding current/voltage		5 A / 8 V ... 220 A / 20 V
Output range, MMA welding current/voltage		15 A / 15 V ... 170 A / 34 V
Output range, TIG welding current/voltage	@MV low range	5 A / 8 V ... 130 A / 16 V
Output range, MMA welding current/voltage	@MV low range	15 A / 15 V ... 75 A / 31 V
Power factor at rated maximum current	λ	1
Efficiency at rated maximum current	η	85 %
Welding connection type		R1/4
Arc striking voltage		11 kV
Stick electrode diameter range		1.6...4 mm
Wired communication type		Analog
Operating temperature range		-20...40 °C
Storage temperature range		-40...60 °C
Recommended minimum generator power [S_{gen}]		8 kVA
EMC class		A
Degree of protection		IP23
External dimensions	$L \times W \times H$	461 x 202 x 367 mm
Weight without accessories		9.6 kg
Standards		EN IEC 60974-1, -3, -10, IEC 61000-3-12

5.2 TIG GUIDE TABLE

 *The values in this chapter are given only as general guidance. The information provided is based solely on the use of WC20 (grey) electrode and Argon gas.*

Welding current range DC		Electrode (WC20)	Gas nozzle		Gas flow rate
Min. A	Max. A	ø mm	Number	ø mm	l/min (Argon)
5	80	1.0	4 / 5	6.5 / 8.0	5...6
70	140	1.6	4 / 5 / 6	6.5 / 8.0 / 9.5	6...7
140	230	2.4	6 / 7	9.5 / 11.0	7...8
225	330	3.2	7 / 8 / 10	11.0 / 12.5 / 16	8...10

5.3 MINARC T 223 DC ORDERING INFO

For Minarc T 223 DC ordering information and optional accessories, refer to [Kemppi.com](https://www.kemppi.com).