

RSA 230

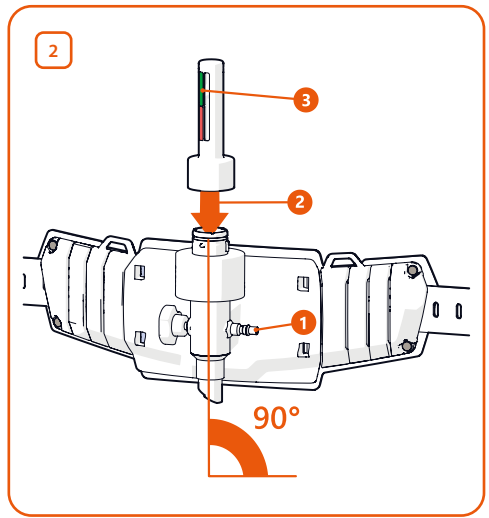

**Operating
manual**

Operating manual – Brugsanvisning – Gebrauchsanweisung – Manual de instrucciones – Käyttöohje – Manuel d'utilisation – Manuale d'uso – Gebruiksaanwijzing – Bruksanvisning – Instrukcja obsługi – Manual de utilização – Manual de utilizare – Инструкции по эксплуатации – Bruksanvisning – Kullanım kılavuzu – 操作手册

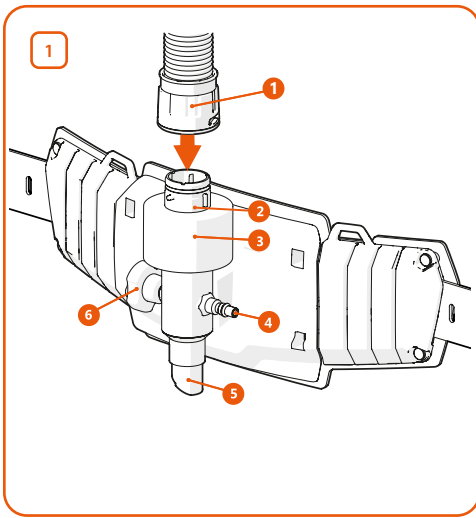

English.....	1
Dansk.....	4
Deutsch.....	7
Español.....	10
Français.....	13
Italiano.....	16
Nederlands.....	19
Norsk.....	22

Polski.....	25
Português.....	28
Română.....	31
Русский.....	34
Suomi.....	37
Svenska.....	39
Türkçe.....	43
中文.....	46



2834



1105



AS/NZS 1716:2012
LIC40175

1. Introduction



1.1 About RSA 230

RSA 230 supplied air regulator enables the welding helmet to be connected to a breathable pressurized air supply. The airflow creates positive pressure inside the headpiece, which prevents the external contaminated air from entering the user's breathing zone while supplying the user with clean breathing air. RSA 230 enables the user to regulate the airflow, and includes an integrated silencer to decrease the noise caused by the pressurized

air. Compatible with Gamma GTH3 SFA/PFA/RFA, Beta FA and Zeta W201/G201 helmets.

1.2 About this manual

Read this manual carefully before using the equipment for the first time. Pay particular attention to the safety instructions.

	Convention	Used For
	Note	Gives the user a piece of information of particular importance.
	Caution	Describes a situation that may result in damage to the equipment or system.
	Warning	Describes a potentially dangerous situation that may result in personal damage or fatal injury.

1.3 Disclaimer

While every effort has been made to ensure that the information contained in this guide is accurate and complete, no liability can be accepted for any errors or omissions. Kemppi reserves the right to change the

specification of the product described at any time without prior notice. Do not copy, record, reproduce or transmit the contents of this guide without prior permission from Kemppi.

2. Safety

Read the following precautions carefully before using the product.

2.1 Precautions

Read the following precautions carefully before using the product.



Warning:

- It is strictly forbidden to use any other than Kemppi branded filters or other parts or accessories with Kemppi's personal protection equipment. If you do not respect this safety regulation, serious damage for your health may occur.



Warning:

- Do not use the system in explosive or highly toxic environments.
- Do not use oxygen-enriched air or oxygen with RSA 230. Risk of explosion.
- Only use the system in environments where the probability of damaging the supply hose is small and the user's movement is not limited.
- Do not use any other pressure hose than the one supplied with RSA 230.
- Maximum working pressure of air supply pressure hose = 2000kPa.
- During an extreme work load, the pressure in the hood may reach negative values, the user may feel air deficiency, and the unit may provide reduced protection.
- Connect the RSA 230 supplied air regulator only to a breathable air supply (air in accordance with EN 12021). Do not connect RSA 230 to any other gas sources.

- Do not connect the RSA 230 supplied air regulator to the breathable air supply simultaneously with other devices.
- If there is a risk of connecting the RSA 230 supplied air regulator to other than a breathable air supply at the workplace, a local risk assessment regarding the use of RSA 230 must be prepared.
- Before each use, check that the air flow is sufficient.
- If the RSA 230 unit's low flow alarm whistle activates, the supply air pressure is not sufficient. Adjust the supply air pressure according to the requirement stated in section Technical data.
- If the system stops supplying air for any reason, leave the contaminated area immediately.
- The system, in a combination with a welding helmet, is not recommended for users with beard or long hair extending to the respiratory zone.
- Beware of a high CO concentration in the air supply, which may occur if the compressor does not work properly when lubricating oil burns due to high temperatures.
- The supply air pressure must be 550-600 kPa.
- Before connecting the unit to the air distribution, check the type and quality of the medium in the line. The RSA 230 units require breathable air that complies with EN 12021 standard.
- Ensure that the air hose is not exposed to sparks, even if an air hose protection cover is used.
- Kemppi RSA 230 system or supply tube is not marked "F" and thus cannot be used in situations where exposure to flame can be a risk. Before use, a local risk assessment must be prepared regarding the need for F-marked equipment.

i **Note:** If you ignore the recommendations stated in this manual, the warranty is automatically invalidated and the level of personal protection may not meet the designated standards.

2.2 Requirements for the compressed air

The RSA 230 unit requires breathable air that complies with EN 12021 standard. Note, for example, the following issues:

- Carbon dioxide concentration: max. 500 ppm.
 - Carbon monoxide concentration: max. 15 ppm.
- The maximum concentration of water in the air: 50 mg/m³ at the rated pressure of 1 – 20 MPa. The

humidity of the supplied air must be controlled to prevent the unit from freezing.

3. Parts 1

1. Air hose to the welding helmet
2. Air hose adapter
3. Replaceable silencer
4. Pressure hose connection
5. Low flow alarm whistle (alarm at 160 l/min)
6. Flow control knob

4. Operating RSA 230

4.1 Inspection before every use

- Check the parts and change any damaged ones.
- Check that the air pressure in the distribution system is 550-600 kPa.
- Perform the air flow test.
- Check that the air hose is properly connected at both ends.
- Ensure that air is supplied into the helmet breathing zone.

4.2 Assembling RSA 230

1. Connect the pressure hose from the compressed air source to RSA 230.

i **Note:** Only use the hose supplied with the product.

2. Fasten the belt around your waist. A shoulder harness is available as an accessory.
3. Connect the air hose to RSA 230 and to the welding helmet.

4.3 Air flow test 2

1. Connect the pressure hose from the compressed air source to RSA 230.
2. Connect a flow meter to RSA 230. Make sure it is properly connected and standing vertically.
3. Check that the ball inside the flow meter rises up to the green area.

5. Daily maintenance

Kemppi recommends cleaning RSA 230 after every use.

- Clean the device with mild soap, lukewarm water, and a soft cloth.
- Rinse the air hose with clean water, if needed.
- Let dry well before reassembling.

i **Note:**

- Always clean RSA 230 in a ventilated room or outside. Be aware of harmful dust settled on the device.
- Do not use cleaning agents containing solvents or abrasives.

6. Storage

Store RSA 230 in an environment with temperature between -20...+50 °C and humidity < 80 % Rh. The product has a two-year storage life if stored in its unopened original packaging. Temporary transportation to and from site is permitted, providing the units are stored in a dry container.

i **Note:** Silencer has a limited lifetime, which is indicated in the silencer label:



7. Troubleshooting

Problem	Probable cause	Recommendation
The unit does not work at all.	Compressed air supply failure	Check the compressed air supply.
	Hose damage	Check whether the connecting hoses are damaged, and replace if necessary.
The unit does not supply the sufficient amount of air.	The air hose or air channel is blocked.	Check and remove the possible obstacle.
	The silencer is blocked.	Replace the silencer.
	Air escapes through leakages.	Check all sealing elements and connections. Check that the hose is not damaged and does not leak.
	The baffle in the pressure flow control unit is clogged.	Replace the baffle.

8. Technical data

Model	RSA 230
Compliance	Regulation (EU) 2016/425 Regulation 2016/425 on personal protective equipment as brought into UK law and amended
Compliance with standards	EN 14594:2018 <ul style="list-style-type: none"> • With Beta FA: 2B class • With Gamma GTH3: 3B class • With Zeta FA: 3B class AS/NZ 1706:2012
Type inspected by	CE: FORCE Certification A/S, Notified body No. 0200 Park Alle 345, DK-2605 Brøndby (Module B). CE: CCQS Certification Services Limited, Notified body No. 2834, Block 1 Blanchardstown Corporate Park, Ballycoolin Road, Blanchardstown, Dublin 15 D15 AKK1 Dublin, Ireland (Module D). AS/NZS: SAI Global Certification Services Pty Limited, Level 7, 45 Clarence Street. Sydney NSW 2000, Australia. UKCA: CCQS UK Ltd., Approved body No. 1105. 25 Wilton Rd, Pimlico, London SW1V 1LW, UK (Modules B & D).
Minimum air flow	160 l/min
Maximum air flow	400 l/min
Length of supply pressure hose	10 m (Pressure hoses must not be connected to each other.)
Required supply air pressure	550-600 kPa
Weight of the unit, hose and belt	1600 g
Belt size	Max. 125 cm
Manufacturer	Kemppi Oy, Kempinkatu 1, P.O. BOX 13, 15801 Lahti, Finland

9. Ordering codes

Part	Code
RSA 230	SP011617
RSA 230 Regulator	SP012857
RSA 230 Silencer, 2 pcs	SP011735
RSA 230 Air hose adapter	SP011227
Pressure hose, 10 m	SP013848

Breathing air hose	SP012253
Harness	SP011894
Flow meter	SP012492
Hose protection cover	SP010788
Leather belt	SP010243

10. Disposal of the unit

 **Note:** Do not dispose of any electrical equipment with normal waste!



At the end of the useful working life of the unit and its accessories, make sure that you follow national and local regulations regarding the disposal of the unit. The unit includes some parts that include or are made of non-environmentally friendly or hazardous materials.

In observance of WEEE Directive 2012/19/EU on waste of electrical and electronic equipment and European Directive 2011/65/EU on the restriction of the use of certain hazardous substances in electrical and electronic equipment, and their implementation in accordance with national law, electrical equipment that has reached the end of its life must be collected separately and taken to an appropriate environmentally responsible recycling facility. The owner of the equipment is obliged to deliver a decommissioned unit to a regional collection centre, as per the instructions of local authorities or a Kemppi representative. By applying these European Directives you improve the environment and human health.



Operating temperature range – Driftstemperaturområde – Betriebstemperaturbereich – Rango temperatura de operación – Käyttölämpötila-alue – Plage de températures d'utilisation – Intervallo temperatura di funzionamento – Bedrijfstemperatuurbereik – Driftstemperaturområde – Zakres temperatur pracy – Faixa de temperatura operacional – Interval temperatură de operare – Диапазон рабочих температур – Driftstemperaturområde – Çalışma sıcaklığı aralığı – 工作温度范围



Recommended humidity range – Anbefalet luftfugtighedsområde – Empfohlener Bereich der Luftfeuchtigkeit – Rango recomendado de humedad – Suositeltu kosteusalue – Taux d'humidité recommandés – Intervallo di umidità consigliato – Aanbevolen luchtvochtigheidsbereik – Anbefalt fuktighetsområde – Zalecana wilgotność – Faixa de umidade recomendada para o uso – Interval de umiditate recomandată – Рекомендуемый диапазон относительной влажности – Rekomenderat fuktighetsområde – Önerilen nem aralığı – 推荐的湿度范围



See information supplied by the RPD manufacturer – Se oplysningerne fra RPD-producenten – Siehe die vom RPD-Hersteller bereitgestellten Informationen – Véase la información suministrada por el fabricante de la unidad RPD – Katso hengityksensuojaimen valmistajan toimittamat tiedot – Voir les informations fournies par le fabricant du RPD – Vedere le informazioni fornite dal produttore RPD – Zie de informatie die is verstrekt door de RPD-fabrikant – Se informasjón som leveres av RPD-tilvirker – Patrz informację podane przez producenta zaworu – Veja as informações fornecidas pelo fabricante do RPD – Consultați informațiile furnizate de producătorul RPD – См. информацию, предоставленную производителем средств индивидуальной защиты органов дыхания – Se information från RPD-tillverkaren – RPD üreticisinin sağladığı bilgilere bakınız – 请参见 RPD 制造商提供的信息

Declaration of Conformity EU/2016/425

Overensstemmelseserklæring – Konformitätserklärung – Declaración de conformidad – Vaatimustenmukaisuusvakuutus – Déclaration de conformité – Dichiarazione di conformità – Verklaring van overeenstemming – Samsvarserklæring – Deklaracja zgodności – Declaração de conformidade – Declarație de conformitate – Заявления о соответствии – Försäkran om överensstämmelse – Uygunluk Beyanı – 符合性声明



userdoc.kemppi.com

