

Gamma 100A

Gamma GTH3 SFA/XFA

Gamma GTH3 SFA AIRLINE

**Operating
manual**

Operating manual – Brugsanvisning – Gebrauchsanweisung – Manual de instrucciones – Käyttöohje – Manuel d'utilisation – Manuale d'uso – Gebruiksaanwijzing – Bruksanvisning – Instrukcja obsługi – Manual de utilização – Manual de utilizare – Инструкции по эксплуатации – Bruksanvisning – Kullanım kılavuzu – 操作手册

1

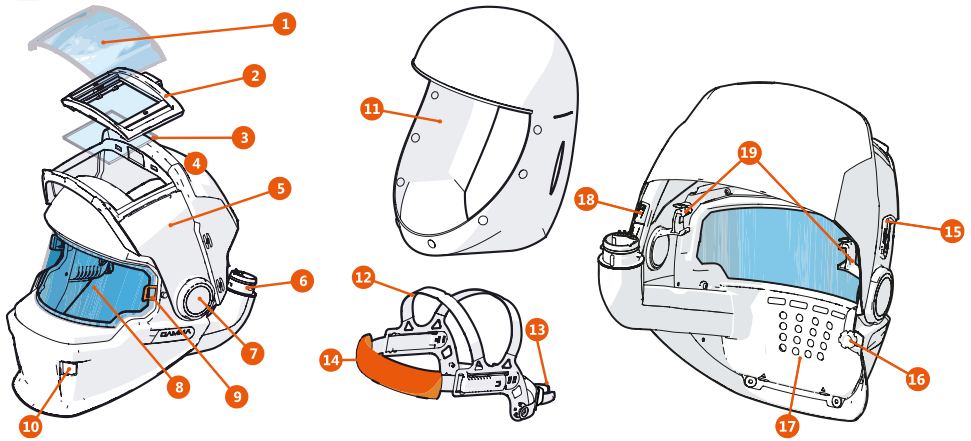

2

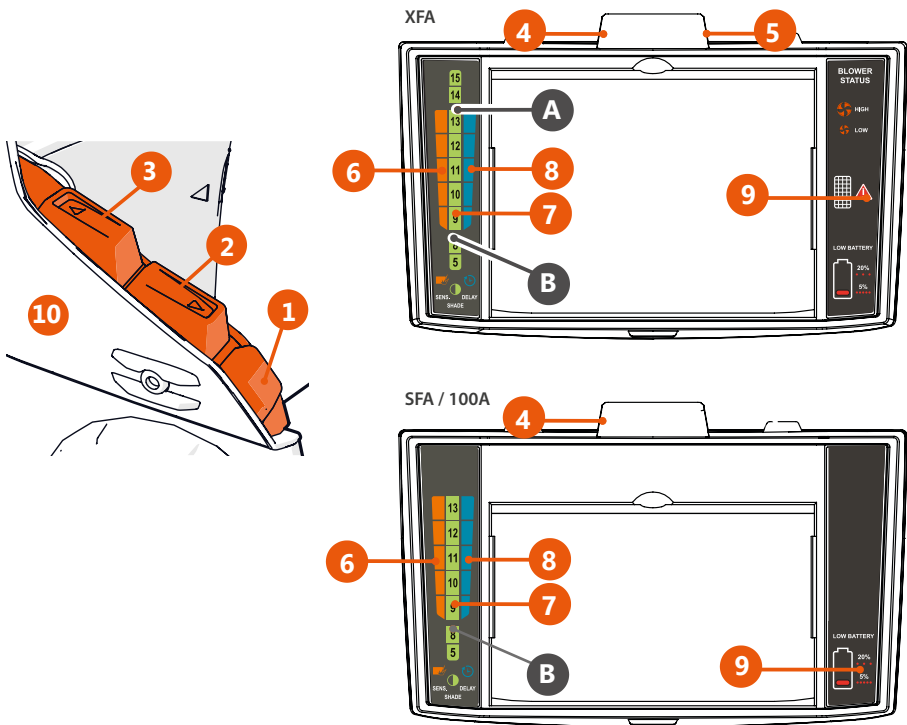

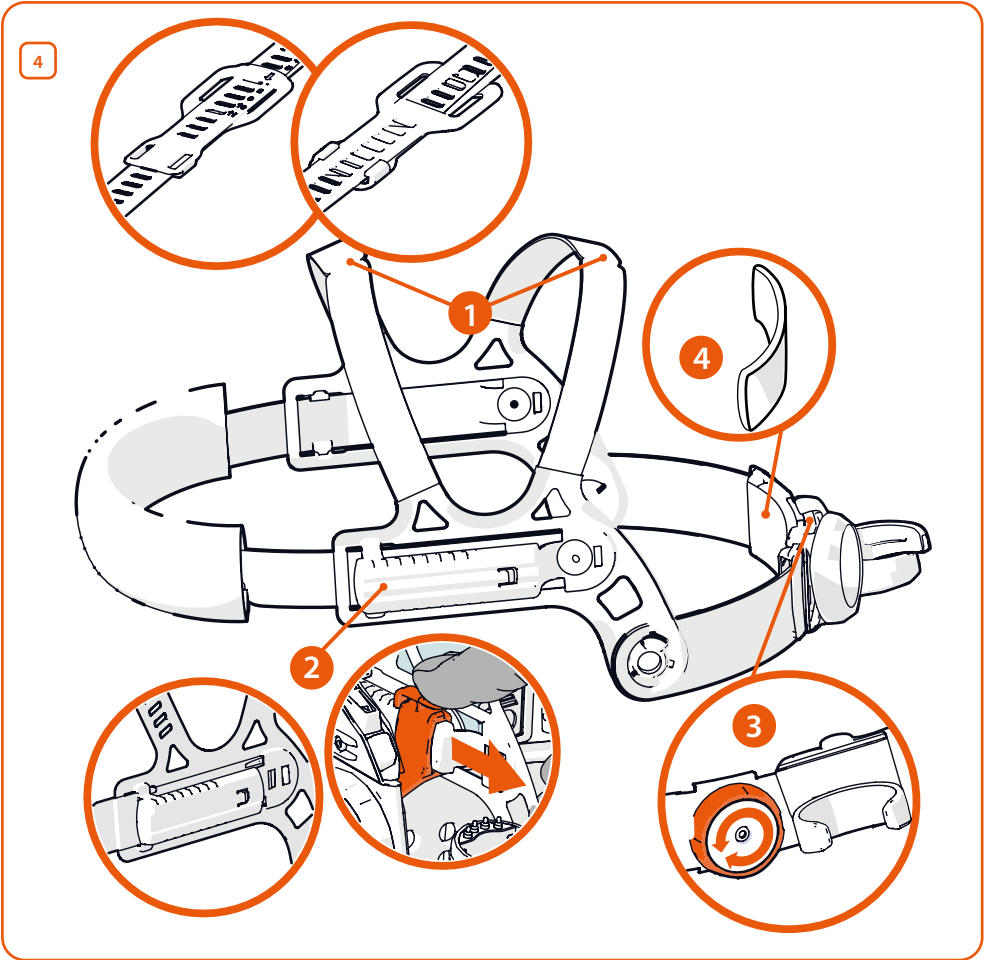
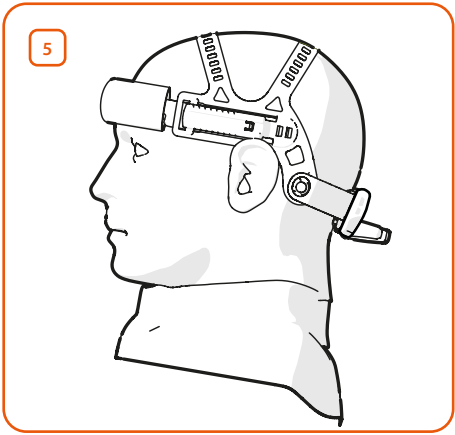
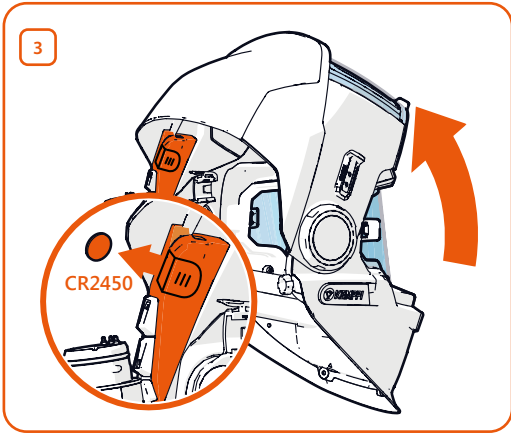

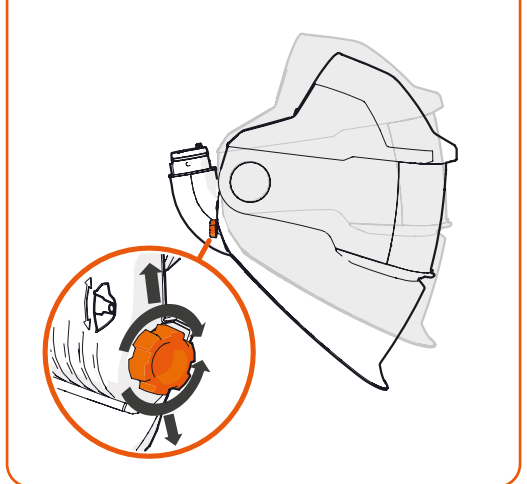
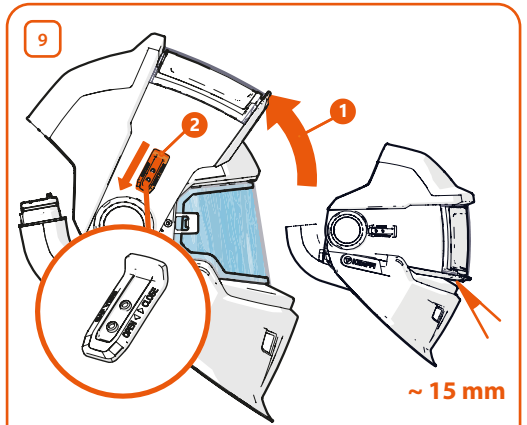
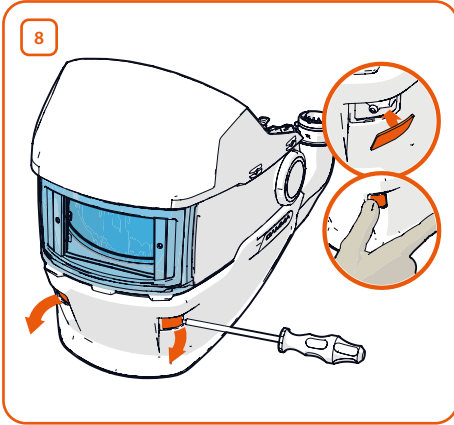
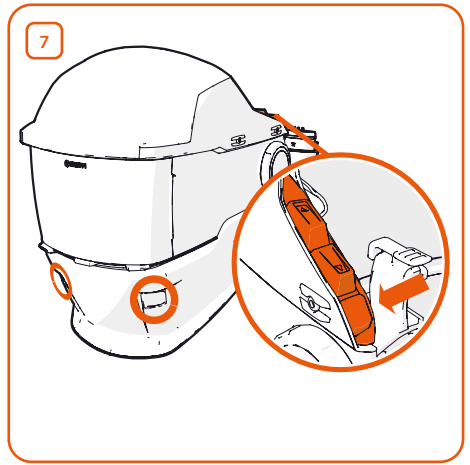
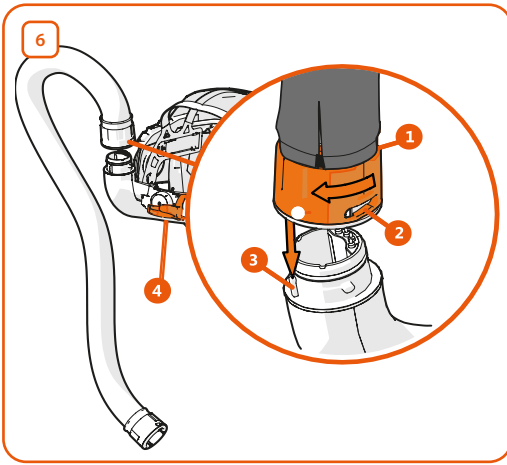

1. Introduction

1.1 About Gamma personal protective equipment

Gamma product models are personal protective equipment (PPE) for welders and fabrication personnel. They are designed for arc welding (MMA, MIG/MAG, TIG), grinding, gouging and plasma cutting.

Gamma welding helmets provide the users with protection for the eyes and face. They combine a flip-up welding visor with a protective grinding visor and include either an auto-darkening filter (ADF) or a passive welding filter lens.



Gamma GTH3 models also protect the user's respiratory system when used together with a compatible powered filter unit (PFU 210e) or supplied air unit (RSA 230). Gamma GTH3 models offer the highest level of respiratory protection: TH3 classification with PFU 210e, and 3B classification with RSA 230.

The following table introduces the features of the Gamma product models.

	GTH3 XFA	GTH3 SFA	GTH3 SFA Airline	100A
Compatible with PFU 210e powered filter unit	●	●		
Compatible with RSA 230 supplied air regulator			●	
Work lights	●			
Auto-darkening filter (ADF)	●	●	●	●

1.2 About this manual

Read this manual carefully before using the equipment for the first time. Pay particular attention to the safety instructions.

	Convention	Used For
	Note	Gives the user a piece of information of particular importance.
	Caution	Describes a situation that may result in damage to the equipment or system.
	Warning	Describes a potentially dangerous situation that may result in personal damage or fatal injury.

1.3 Disclaimer

While every effort has been made to ensure that the information contained in this guide is accurate and complete, no liability can be accepted for any errors or omissions. Kemppi reserves the right to change the specification of

the product described at any time without prior notice. Do not copy, record, reproduce or transmit the contents of this guide without prior permission from Kemppi.

2. Safety

Gamma personal protective equipment helps protect the wearer's eyes from harmful radiation including visible light and ultra-violet/infra-red radiation resulting from certain welding processes.



Warning:

- It is strictly forbidden to use any other than Kemppi branded filters or other parts or accessories with Kemppi's personal protection equipment. If you do not respect this safety regulation, serious damage for your health may occur.



Warning:

- We recommend a usage period of 5 years. The period of use depends on various factors such as use, cleaning, storage and maintenance. Inspect the helmet before each use. Replace damaged or worn parts. Never use a scratched or damaged welding filter and ocular.
- Use all adjustment features for maximum protection.
- Never weld with the welding visor up or without the welding filter.



Warning:

- If the auto-darkening filter (ADF) does not darken when the arc ignites, stop welding immediately. Inspect the ADF and its power supply. Change if necessary.
- Always use welding filters together with suitable protection plates.
- Never use welding filter without inner protection plates.
- Materials which may come into contact with the wearer's skin may cause allergic reactions to suscep-

tible individuals.

- Only operate this product within the temperature range -5...+55 °C.
- The product is not intended for use in environments with a risk of explosion.
- The helmet does not protect against explosive devices or corrosive liquids.
- The helmet is not suitable for laser welding and oxy-acetylene welding/cutting processes.
- Set and tighten the face seal properly. If the face seal is not tight, the respiratory protection may not reach the best level.
- The helmet gives designed protection against high speed particles only at room temperature (EN175 B) and only when all helmet components are properly attached, as described in the manual.
- If the symbols of the marking are not common to different parts of the protection equipment, the lower protection level shall be assigned to the complete protection equipment.
- If protection against high speed particles at extremes of temperature is required then the selected eye-protector should be marked with the letter T immediately after the impact letter, i.e. FT, BT or AT. If the impact letter is not followed by the letter T then the eye protector shall only be used against high speed particles at room temperature.

When helmet is worn over any spectacles, they may transmit the impact of high speed particles, thus creating a hazard to the wearer.

3. Parts 1

- Front cover lens
- Welding filter:
 - auto-darkening filter SA 60 (SFA, 100A)
 - auto-darkening filter XA 74 (XFA)
- Inner protection plate
- Welding visor
- Side cover plate of the welding visor
- Air duct for the respirator (SFA, XFA)
- Welding helmet rigidity adjustment knob.
- Grinding visor
- Grinding visor lock

- Work lights (XFA)
- Face seal: washable (SFA, XFA)
- Headband
- Air hose holder (SFA, XFA)
- Sweatband: washable
- Gap view switch: Control the gap view.
- Angle regulator knob: Adjust the viewing angle.
- Air duct nozzle (SFA, XFA)
- Remote control buttons for adjusting the ADF (SFA, XFA, 100A)
- Distance slide adjusters: Connect the headband to the helmet and adjust the distance of the helmet from the face.

4. Auto-darkening welding filter (ADF) 2

- Work light on/off (long press, XFA) and ADF mode selector (short press)
- Scroll down
- Scroll up
- USB port for ADF power and remote control (SFA, XFA, 100A)
- USB port for work lights and PFU 210e indicators (XFA)
- Sensitivity indicator: 5 levels
- Shade indicator: Shades 5/8 - 15 (XFA) or 5/8 - 13 (SFA and 100A)
A long press of the Scroll up/down button moves you to another shade block at points (A) and (B).
- Delay indicator: 5 levels
- Indicators for the PFU 210e battery, filter and blower (XFA).
Indicator for the ADF battery (SFA/100A).
- Battery casing

To move between sensitivity/shade/delay columns (6 - 8), shortly press the ADF mode selector (1). At the correct column, use the Scroll up/down buttons (2 - 3) to change the value.

Sensitivity defines how easily the ADF photo-sensors respond to arc light and trigger the darkening of the filter.

Shade defines how dark the ADF gets when the welding arc ignites. To select the optimal shade for the job at hand, see table Shade selection.

Delay defines how fast the ADF returns to the light state after welding has stopped.

 **Note:** To use the control buttons, make sure the USB connector is connected to the USB port (4).

XFA:  ADF is powered by the PFU 210e battery. If the connection to PFU 210e is cut off, ADF is powered by the battery inside the battery casing on the helmet. Check the battery regularly.







SFA, 100A:  ADF is powered by the battery inside the battery casing on the helmet.

Table 2: PFU 210e indicators (inside XFA helmet)

	<p>Battery status:</p> <ul style="list-style-type: none"> • Blinking slowly: the battery charge level is 20%. • Blinking rapidly: the battery charge level is 5%.
	<p>Filter status: When illuminated, change the filter.</p>
	<p>Blower status: normal and high blower speed. (When the gas filter is used, only normal speed is available.)</p>

5. Taking the product into use

1. Check that the product has not been damaged during the transport.
2. Adjust the helmet for your head:
 - A. Use the top bands to adjust how deep the helmet sits (1).
 - B. Use the distance slide adjuster to change the distance of the welding helmet from your face (2).
 - C. Turn the knob to tighten and secure the headband (3).
 - D. Attach the optional comfort band padding for additional comfort.
-  Make sure the helmet sits deep enough on your head, as shown in the picture.
3. Connect the air hose to the helmet and to a respiratory protection device (SFA, XFA): 
 - A. Turn the air hose connector (1) to fully expose the openings (2).
 - B. Align the groove in the air hose connector with the tab in the air duct (3).
 - C. Push the connector into the air duct.
 - D. Turn the connector clockwise to snap-lock the air hose into its place.
 - E. Secure the air hose into the air hose holder (4) to keep it out of the way.
4. Turn on the powered filter unit / air supply.
5. Set and tighten the face seal properly around your face, in front of the ears and under the chin using all three strap tighteners in the face seal.

 **Warning:** If the face seal is not tight, the respiratory protection may not reach the best level.

6. Using the helmet features

6.1 Work lights 7

Gamma GTH3 XFA has LED work lights that are powered by the PFU 210e battery. Press and hold the work light remote control button until the light turns on.

 **Note:** Make sure both USB connectors are connected.

To replace worn protective lenses on the work lights: 8

1. Remove the worn protective lenses with a screwdriver.
2. Insert the new protective lenses, starting from the outer edge.

 **Note:** Note that the left and right protective lenses are slightly different in shape.

7. Replacing parts

To replace the outer protection plate: 10

1. Use the grooves on the sides to pull the plate out.
2. To insert a new plate, push at the corners to snap-lock the corner grooves into place.

Before removing the welding filter cassette: 11

Before removing the welding filter cassette, detach the USB connector(s): either two (XFA), or one on the left (SFA, 100A).

 **Note:** When inserting the USB connector, the wider side goes up.

 **Caution:** Do not connect the USB connector to any other device.

To replace the welding filter cassette: 12

1. Remove the cassette by pressing the tab behind the lower edge of the cassette, and then pushing the cassette forward.
2. Insert the cassette by first pushing the upper edge tabs (1) into place, then the lower edge into its groove (2).

To replace the grinding visor: 13

1. Pull the grinding visor locks slightly outwards, and pull the visor out.
2. To insert the visor, align the grooves in the visor with the visor locks, and snap the visor into its place.

 **Note:** Make sure both sides snap into their place.

6.2 Gap view 9

1. Lift the welding visor up.
2. Push the gap view adjuster to OPEN position (towards the visor knob).

6.3 Adjusting the viewing angle 9

Turn the viewing angle adjuster to tilt the viewing angle upwards or downwards.

Tip: When adjusting the helmet upwards, support the helmet with the other hand.

To remove the headband: 14

1. Press and hold down the slide adjuster button (3).
2. Push the headband connector (1) forwards, out of the distance slide adjuster (2).

To replace the face seal: 15-16

1. Remove the headband.
2. Open the face seal snap fasteners (5).
3. To remove the face seal, slide the face seal's top sealing strip (1) out of the groove on the inside of the helmet (2) and remove the face seal.
4. To attach the face seal back, slide the face seal's top sealing strip (1) back into the groove on the inside of the helmet (2). Make sure the face seal is positioned in the middle.
5. Pass the distance slide adjusters and the air duct through the openings in the face seal (3, 4).
6. Secure the face seal in place with the snap fasteners (5).
7. Attach the headband back in place.

To attach the headband: 17

1. Bring the headband connector in front of the distance slide adjuster.
2. Press down the slide adjuster button while pushing the headband connector through the distance slide adjuster.
3. Slide the headband connector in place so that the slide adjuster pin locks into one of the grooves in the headband connector.
4. Ensure that the welding helmet is at a convenient distance from your face and that both sides are equally positioned.

8. Maintenance

Inspect the helmet after each use. Replace worn or damaged parts.

8.1 Cleaning

- Clean the protection plate and grinding visor with mild soap, lukewarm water and a soft cloth.
- Wipe the welding filter lens with a soft, clean cloth, if necessary.
- Detach and wash the sweatband and face seal, if necessary.



Note: The fire retardant on the face seal gradually wears out in wash. Wash the face seal max. 5 times.

8.2 Cleaning the air duct nozzle 18

1. Remove the air duct nozzle by pushing a tool under the two grooves below the plate.
2. Wipe the nozzle and the area behind it with a soft cloth and mild detergent or suitable disinfecting mask spray. Dry well before reassembling.

8.3 Shade selection

Shade numbers according to EN 169 (DIN shades) 19

9. Storage

Store the Gamma welding helmet in an environment with temperature between -20...+50 °C and humidity < 80 % Rh.

Store and transport the helmet and the accessories in the original bag or package.

10. Technical data

Compliance with standards	<ul style="list-style-type: none"> • EN 175:1997-08, Personal protection. Equipment for eye and face protection during welding and allied processes • EN 166:2002-04, Personal eye protection, specifications • Regulation 2016/425 • EN 169 • EN 379 • EN 12941 (TH3 together with PFU 210e) (TH3 = Max. inward leakage 0.2 %) • EN 14594 (3B together with RSA 230) (3B = Max. inward leakage 0.5 %) • AS/NZS 1716 (PAPR-P2) • AS/NZS 1337.1 (B) • AS/NZS 1338.1
Type inspected by:	<p>EN 12941, EN 14594: CE: FORCE Certification A/S, Park Alle 345, 2605 Brøndby, Denmark. Notified Body No. 0200 (Module B)</p> <p>CE: CCQS Certification Services Limited, Notified body No. 2834, Block 1 Blanchardstown Corporate Park, Ballycoolin Road, Blanchardstown, Dublin 15 D15 AKK1 Dublin, Ireland (Module D).</p> <p>EN 175: CE: DIN CERTCO Gesellschaft für Konformitätsbewertung mbH Alboinstr. 56D-12103 Berlin, Germany. Notified Body No. 0196</p> <p>UKCA: TUV Rheinland UK Ltd. Friars Gate (Third Floor), 1011 Stratford Road, Shirley, Solihull, B90 4BN, UK. Approved Body No. 2571 (UKCA for 100A)</p> <p>UKCA: CCQS UK Ltd. 25 Wilton Rd, Pimlico, London SW1V 1LW, UK. Approved Body No. 1105 (UKCA for SFA & XFA)</p>
Authorized representative: (UKCA)	Kemppi UK: Martti Kemppi Building, Priory Business Park, Fraser Road, MK44 3WH Bedford, UK
Manufacturer:	Kemppi Oy PL 13, Kempinkatu 1, 15801 LAHTI, FINLAND
Model:	GTH3 XFA, GTH3 SFA, 100A
ADF switching time	0.1 ms
ADF light state	Shade 4
ADF ultraviolet/infrared protection	Protection at all times
Operating temperature	-5°...+55 °C
Battery type (inside the remote control)	CR2450

Materials	Plastics: PA, PP, PC, ABS, POM Sweatband material 100 % cotton, padding foam plastic
Weight	GTH3 XFA: 1100g 100A: 775 g GTH3 SFA: 1002 g

Marking explanation of welder's face shield:

KMP EN 175 B CE UKCA

Symbol	Description of the field of use
KMP	Manufacturer's mark
EN 175	Number of the standard
B	Mechanical strength

EN 175 B: Personal protection, Equipment for eye and face protection during welding and allied processes.

Symbol	Type of protection	Description of the field of use
S	Increased robustness	Mechanical strength
-F	Low energy impact 45 m/s	Mechanical strength
-B	Medium energy impact 120 m/s	Mechanical strength

Front cover lens marking – KMP B CE UKCA

Ocular marking – KMP 1 B CE UKCA

KMP	Identification of the manufacturer
1	Optical class (except for cover plates)
B	Symbol for mechanical strength
CE	CE marking (European Conformity)
UKCA	UKCA marking (UK Conformity)

11. Ordering codes

Part	Ordering code
Face seal	SP009794
Front cover lens, 5 pcs	SP008034
Welding visor frame assembly	SP007996
Visor knob assembly	SP008152
LiFE+ -visor, 5 pcs	SP008040HC
Grinding visor, clear, 5 pcs	SP008040
Grinding visor, yellow, 5 pcs	SP008040Y
ADF welding filter SA 60	SP012422
ADF welding filter XA 74	SP012421

Part	Ordering code
Remote control	SP012097
Inside protection plate, ADF SA 60	SP012425
Inside protection plate, ADF XA 74	SP012424
Side cover plates	SP012053
Headband	SP009023
Sweatband, 2 pcs	SP9873018
Comfort band padding	SP013231
Work light solid cover plate, 3 pcs	SP010526

11

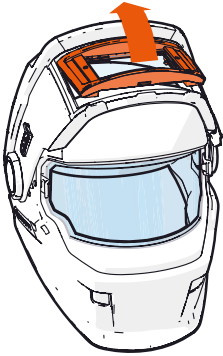
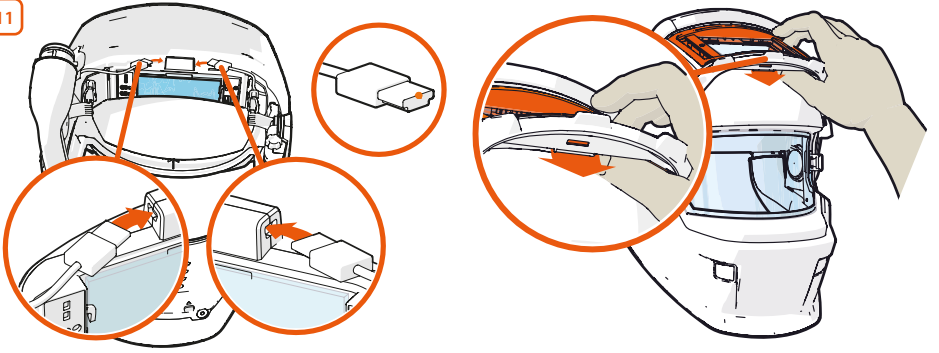

12

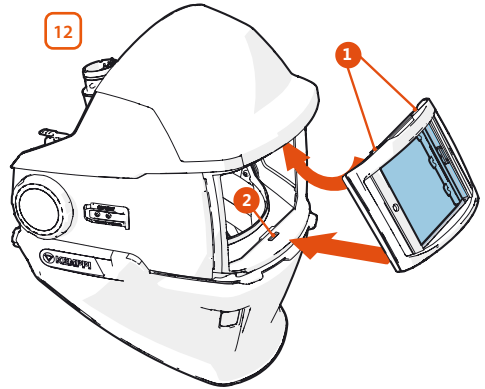

13

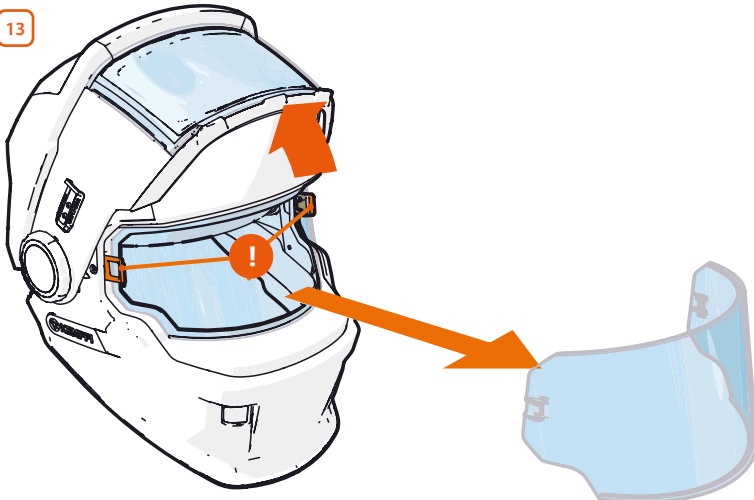

14

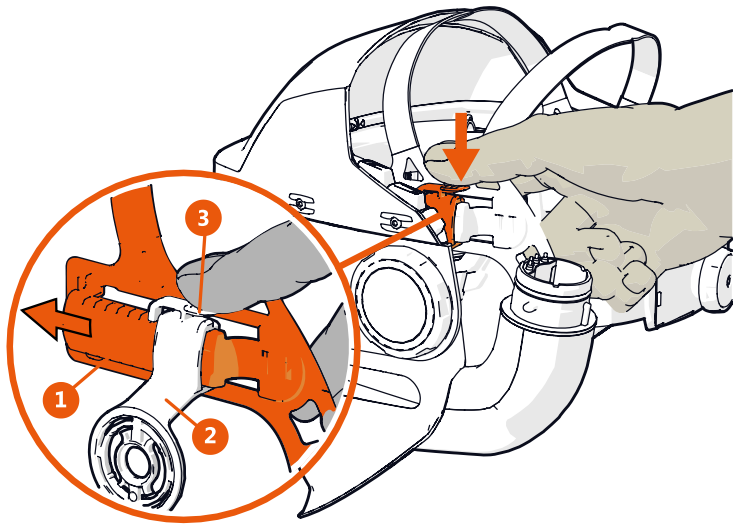

15

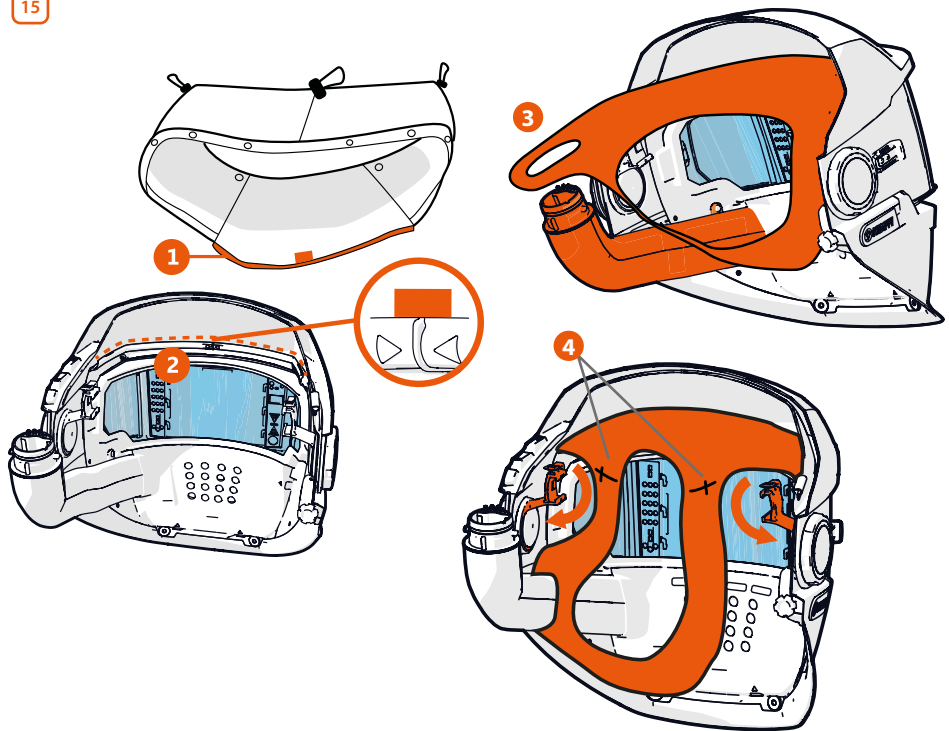

16

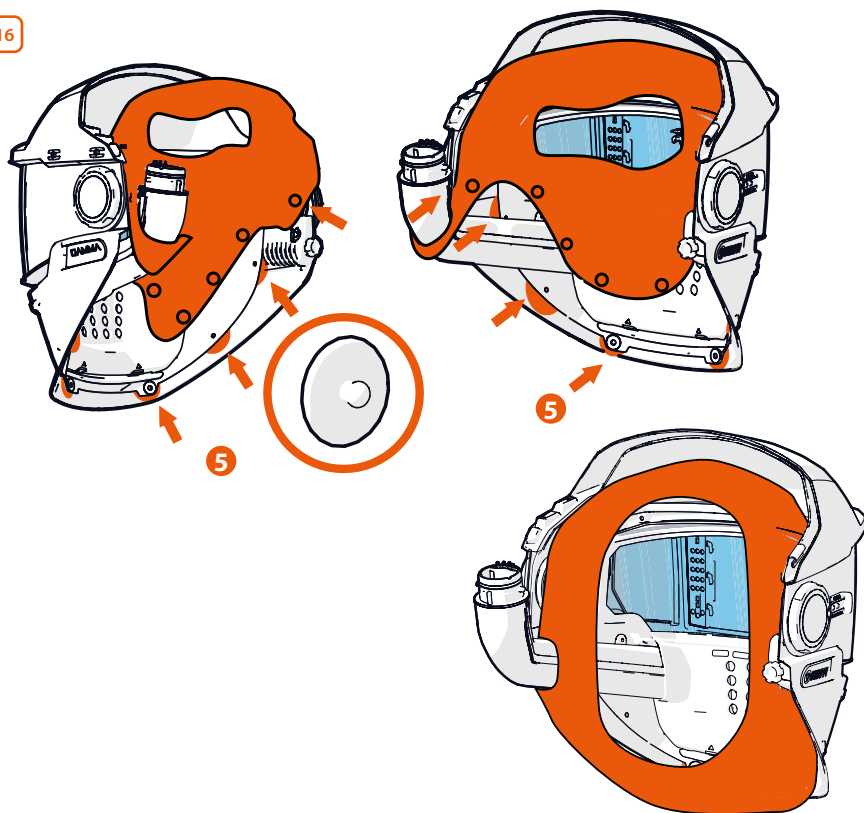

17

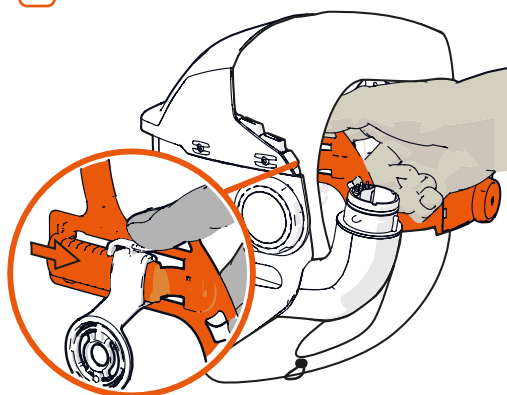

18

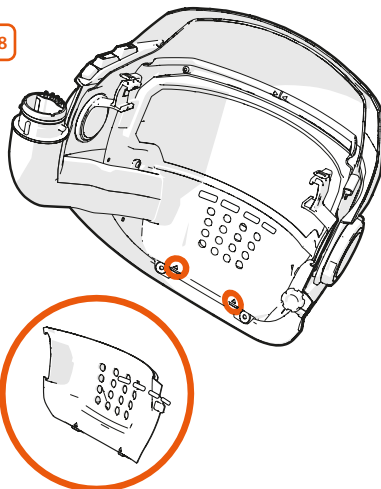

19	MMA (E-Hand)	MIG, Ss	MIG, AI	MAG, CO ₂	TIG	Gouging	Plasma cutting
15 A					9		
20 A	9				10		
30 A							
40 A	10			10	11		
60 A		10	10				
80 A				11			11
100 A	11						
125 A		11	11	12	12	10	
150 A							
175 A							
200 A			12		13	11	12
225 A	12	12		13		12	
250 A							
275 A			13		14	13	13
300 A							
350 A				14			
400 A	13	13	14			14	
450 A							
500 A	14	14		15		15	
550 A			15				
600 A	15	15					



Welding helmet weight – Svejsehjelmens vægt – Gewicht der Schweißerschutzmaske – Peso de la máscara de soldadura – Hitsauskypärän paino – Poids du masque de soudage – Peso del casco per saldatura – Gewicht lashelm – Sveisemaskevekt – Masa przyłbicy – Peso da máscara de soldagem – Greutate de căștii de sudură – Масса сварочной маски – Svetshjälms vikt – Kaynak kaski ağırlığı – 电焊帽重量



See information supplied by the RPD manufacturer – Se oplysningerne fra RPD-producenten – Siehe die vom RPD-Hersteller bereitgestellten Informationen – Véase la información suministrada por el fabricante de la unidad RPD – Katso hengityksensuojaimen valmistajan toimittamat tiedot – Voir les informations fournies par le fabricant du RPD – Vedere le informazioni fornite dal produttore RPD – Zie de informatie die is verstrekt door de RPD-fabrikant – Se informasjon som leveres av RPD-tilvirker – Patrz informacje podane przez producenta zaworu – Veja as informações fornecidas pelo fabricante do RPD – Consultați informațiile furnizate de producătorul RPD – См. информацию, предоставленную производителем средств индивидуальной защиты органов дыхания – Se information från RPD-tillverkaren – RPD üreticisinin sağladığı bilgilere bakınız – 请参见 RPD 制造商提供的信息



userdoc.kemppi.com



Declaration of Conformity – Overensstemmelseserklæring – Konformitätserklärung – Declaración de conformidad – Vaatimustenmukaisuusvakuutus – Déclaration de conformité – Dichiarazione di conformità – Verklaring van overeenstemming – Samsvarserklæring – Deklaracja zgodności – Declaração de conformidade – Declarație de conformitate – Заявления о соответствии – Försäkran om överensstämmelse – Uygunluk Beyanı – 符合性声明

Quality assurance of the production process (Module D):
CCQS Certification Services Limited
Block 1 Blanchardstown Corporate Park,
Ballycoolin Road, Blanchardstown,
Dublin 15 D15 AKK1 Dublin, Ireland
Notified body No. 2834

