

Flexlite GX

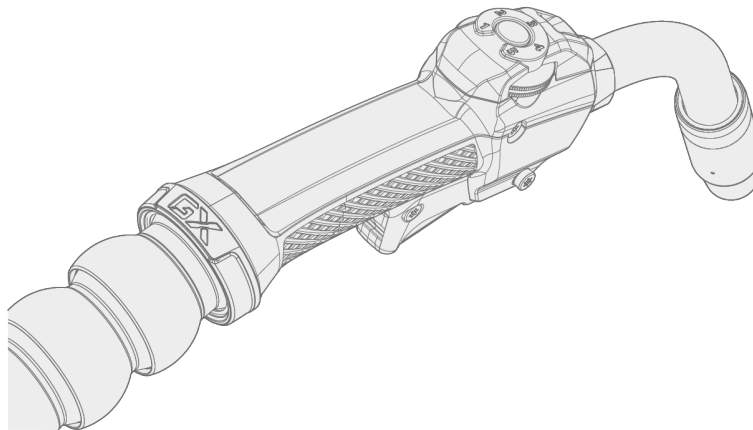

CONTENTS

1. General	3
2. About equipment	5
3. Installation	7
3.1 Assembling gun	8
3.2 Installing gun remote	9
3.3 Connecting gun	11
3.4 Installing and replacing wire liner	12
3.4.1 Replacing DL Chili wire liner	12
3.4.2 Replacing steel wire liner	16
3.4.3 Replacing wire liner for multi-neck	21
3.5 Trigger switch replacement	24
3.5.1 Trigger switch setting (GX series 5) – W015263 until 9/2020	25
3.5.2 Trigger switch setting (GX series 5) – W015263 since 10/2020	26
3.5.3 Trigger switch setting (GX series 5) – W022322	28
3.6 Installing and removing grip handle (optional)	30
3.7 Adjusting and tightening neck (gas-cooled models)	31
4. Operation	32
4.1 Using gun remote GXR10 (series 5)	33
4.2 Using gun remote GXR80B (series 8)	34
5. Maintenance	36
5.1 Troubleshooting	38
5.2 Disposal	40
6. Technical data	41
6.1 Technical data: Flexlite GX 200A/250A (gas-cooled)	42
6.2 Technical data: Flexlite GX 300A/350A (gas-cooled)	44
6.3 Technical data: Flexlite GX 250A/300A (water-cooled)	46
6.4 Technical data: Flexlite GX 400A (gas-cooled)	48
6.5 Technical data: Flexlite GX 300A/400A/420A (water-cooled)	50
6.6 Technical data: Flexlite GX 500A/520A (water-cooled)	52
6.7 Technical data: Flexlite GX 600A (water-cooled)	54
6.8 Technical data: Flexlite GX HD 300A (gas-cooled)	56
6.9 Technical data: Flexlite GX HD 400A (gas-cooled)	58
6.10 Component selection	60
7. Ordering codes	62

1. GENERAL

These instructions describe the use of Kemppi's Flexlite GX MIG welding guns. Flexlite GX welding guns are designed for professional manual welding. Flexlite GX range covers both water-cooled and gas-cooled models for MIG welding. Flexlite GX welding guns are available in three different series – 3, 5 and 8 – each designed to serve specific welding needs.

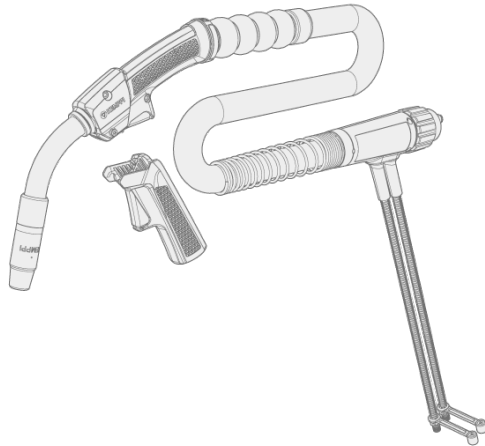

Flexlite GX models		
Series 3*:	Series 5**:	Series 8***:
GX 203G	GX 205G	GX 208GMN
GX 253G	GX 255G	GX 308GMN
GX 303G/W	GX 305G/W	GX 408GMN
GX 303GHD	GX 305GHD	GX 428W
GX 403G/W	GX 305GMN	GX 428WS
GX 403GHD	GX 305GS	GX 528W
GX 503W	GX 305WS	GX 608W
	GX 405G/W	
	GX 405GHD	
	GX 405WS	
	GX 505W	
	GX 605W	

* Series 3 welding gun models are compatible with the majority of welding equipment.

** Series 5 welding gun models are designed for Kemppi Fastmig equipment with limited support to other models.

*** Series 8 welding gun models are compatible with Kemppi X8 MIG Welder.

In model names: G = gas-cooled, W = water-cooled, MN = multi-neck, S = long cable, HD = heavy-duty.

Important notes

Read the instructions through carefully. For your own safety, and that of your working environment, pay particular attention to the safety instructions delivered with the equipment.

Items in the manual that require particular attention in order to minimize damage and harm are indicated with the below symbols. Read these sections carefully and follow their instructions.



Note: Gives the user a useful piece of information.



Caution: Describes a situation that may result in damage to the equipment or system.



Warning: Describes a potentially dangerous situation. If not avoided, it will result in personal damage or fatal injury.

Kemppi symbols: [Userdoc](#).

DISCLAIMER

While every effort has been made to ensure that the information contained in this guide is accurate and complete, no liability can be accepted for any errors or omissions. Kemppi reserves the right to change the specification of the product described at any time without prior notice. Do not copy, record, reproduce or transmit the contents of this guide without prior permission from Kemppi.

2. ABOUT EQUIPMENT

The Flexlite GX MIG welding gun equipment consists of:

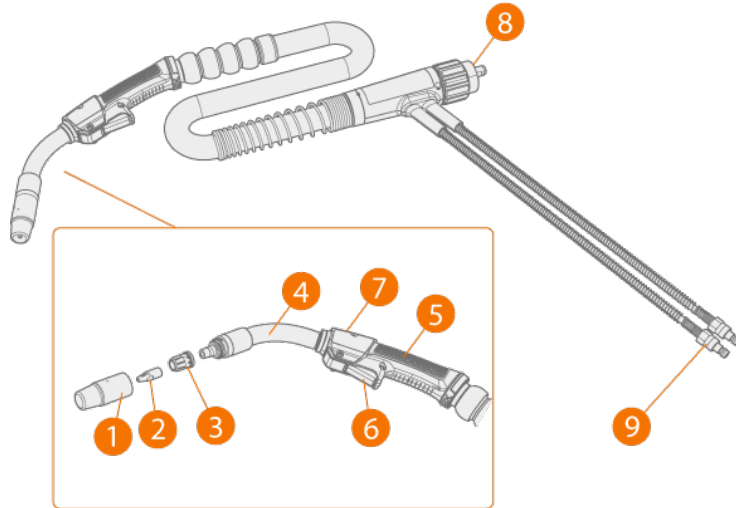

 The exact visual details may be different between different Flexlite GX models.

1. Gas nozzle
2. Contact tip
3. Contact tip adapter / gas diffuser
4. Gun neck
5. Handle
6. Trigger switch
7. Cover plate
 - >> This covers the handle if a welding gun remote is not used (Flexlite GX series 5 and series 8 models). For more information on the gun remotes, refer to "Installing gun remote" on page 9.
 - >> Not available with Flexlite GX series 3 models.
8. Gun connector
9. Coolant inlet and outlet hose connectors
 - >> With water-cooled welding guns only.

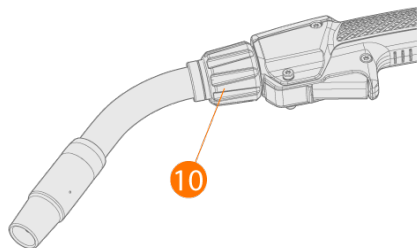

10. Neck tightening collar
 - >> With multi-neck welding guns only.

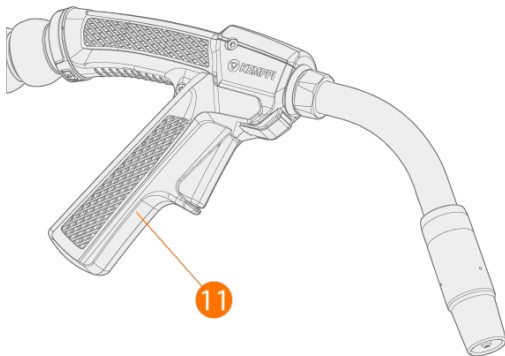
**11. Additional grip handle**

EQUIPMENT IDENTIFICATION

Quick Response (QR) code

Device-related information or a web link to such information may be found in the form of a QR code on the device. The code can be read, for example, with a mobile device camera and a QR code application.

3. INSTALLATION



Ensure that the welding equipment is not connected to the mains or that the welding gun is not connected to the welding machine until the installation is complete.



Protect the equipment from rain and direct sunshine.

"Assembling gun" on the next page

"Installing gun remote" on page 9

"Connecting gun" on page 11

"Replacing steel wire liner" on page 16

"Replacing wire liner for multi-neck" on page 21

"Installing and removing grip handle (optional)" on page 30

"Adjusting and tightening neck (gas-cooled models)" on page 31

Before installation and use

Ensure compliance with your local and national safety requirements regarding the installation and use of high voltage units.

Check the contents of the packages and make sure the parts are not damaged.

3.1 Assembling gun

 For the correct components, refer to "Component selection" on page 60.

Tools needed:



8mm

1. Attach the contact tip adapter and hand-tighten it firmly in place. It is important to tighten the adapter properly to enable a tight connection of the contact tip to the gun.
2. Attach the contact tip and secure it with the 8 mm spanner.
3. Attach the gas nozzle and hand-tighten it firmly in place.

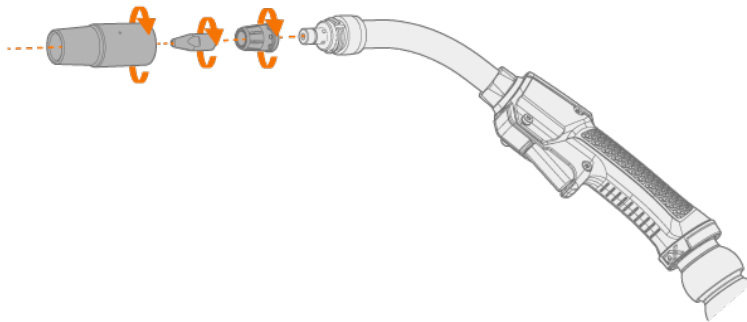



With multi-neck gun models only:

4. Attach the assembled neck to the gun body. Secure with the neck tightening collar.

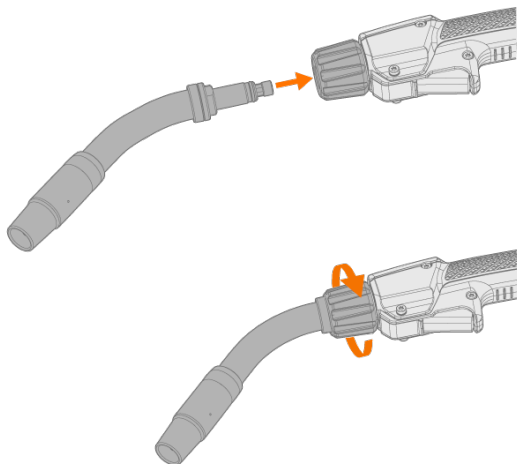
 Hand-tighten the neck tightening collar only. Over-tightening and/or using a tool can damage the gun components.



3.2 Installing gun remote

-  The Flexlite GX series 5 welding gun remote (GXR10) can be used with Kemppi Fastmig equipment only.
-  The Flexlite GX series 8 welding gun and digital gun remote (GXR80B) can be used with Kemppi X8 MIG Welder only.
-  Ensure that the welding equipment is not connected to the mains or that the welding gun is not connected at this stage.

Tools needed:



TX20

1. Remove the cover by releasing the screws on the sides and then moving the cover slightly forward and up.

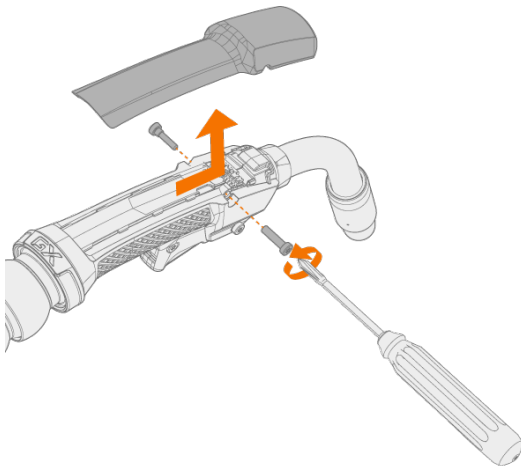

2. Remove the existing circuit board chip from the connectors inside the gun.

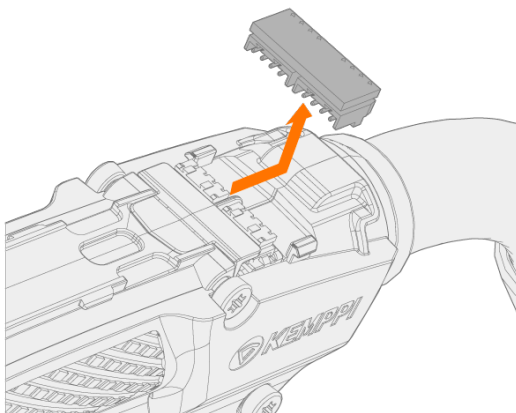

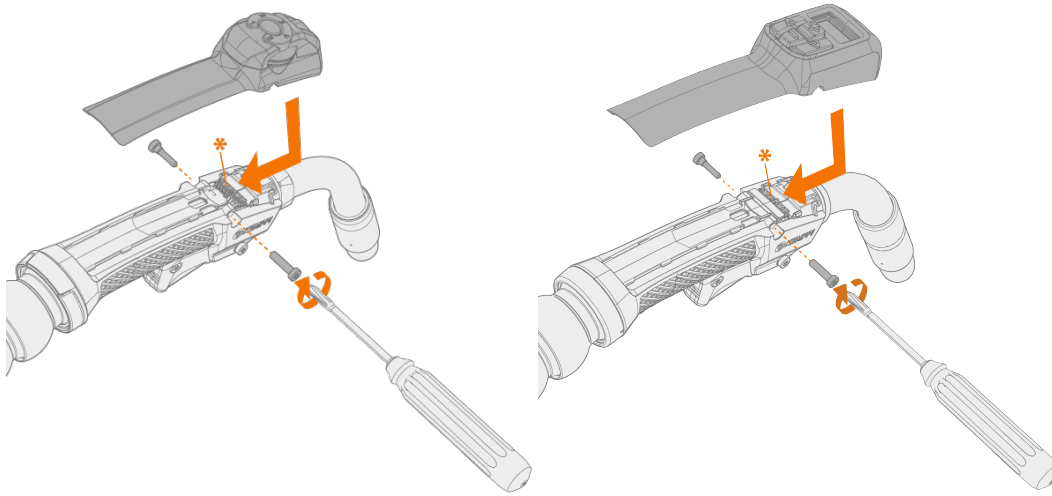

3. Set the new gun remote control cover against the gun body slightly off to the front and slide it backward so that the connectors (*) align and connect.



4. Secure the remote control cover in place with the screws from the sides.

3.3 Connecting gun

-  *Hand-tighten the gun connectors. Loose connectors may overheat, create contact disturbances, mechanical damage and water or gas leakage.*
-  *For connecting the gun (and applicable extension parts), refer also to your welding equipment's instructions.*
-  *If not already preinstalled, the wire liner must be installed before connecting the gun. Refer to "Replacing steel wire liner" on page 16 for instructions.*

- 1.** Connect the gun to your welding equipment. Secure the connector in place by turning the collar clockwise.

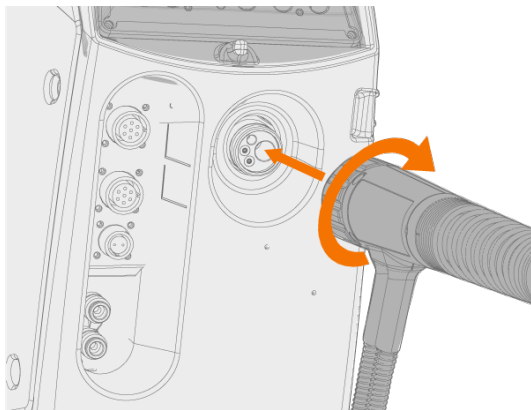

- 2.** Water-cooled models only: Connect the coolant inlet and outlet hoses to your welding equipment. Note that the connectors are color-coded.

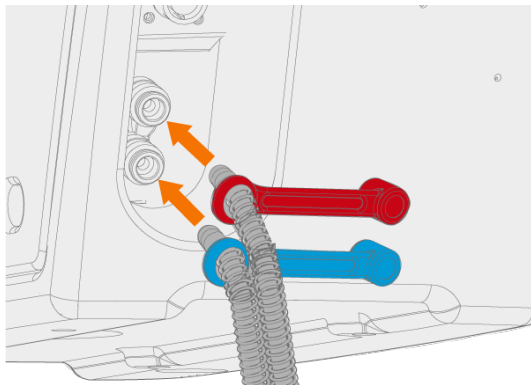

-  *Make sure to connect the coolant hoses to the correct hose connectors. If the connections cross, the welding gun may overheat.*

3.4 Installing and replacing wire liner

The Flexlite GX MIG welding gun cable packs are delivered with the wire liner preinstalled, except the S-models (long cable packages). Refer to this section when the wire liner needs to be replaced or when taking a Flexlite GX S-model in use.

The wire liner is a consumable part, which needs to be changed if worn and when the filler wire material changes.

For replacing the steel wire liner, refer to "Replacing steel wire liner" on page 16.

For replacing the DL Chili wire liner, refer to "Replacing DL Chili wire liner" below.

For the multi-neck wire liner replacement, refer to "Replacing wire liner for multi-neck" on page 21 in conjunction with the main wire liner replacement instructions.

 *If you change the filler wire to a different diameter or material, change also the feed rolls in the wire feed system accordingly.*

 *With most of the Flexlite GX welding gun models both steel wire liner and DL Chili wire liner can be used. However, with Flexlite GX S-models, it is recommended to use only DL Chili wire liners.*

 *The filler wire must be removed before the wire liner replacement.*

This replacement instruction applies to wire liners with a joint end cap and sleeve nut assembly (A). For replacing a wire liner using a separate end cap and sleeve nut assembly (B), refer to the instructions [here \(pdf\)](#). Always read the instructions delivered with the replacement wire liner as well.

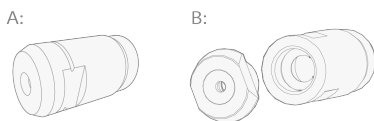

3.4.1 Replacing DL Chili wire liner

Tools needed:



Removing and inserting wire liner

This same method applies to both Euro connector (GX series 3 and 5) and Kemppi connector (GX series 8) welding guns, but the visual details may vary. The method is the same also for both gas- and water-cooled welding guns.

1. Straighten the welding gun cable pack.

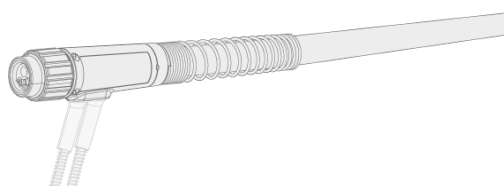

- At the wire feeder end of the cable, remove the wire liner's sleeve nut and retainer cone.

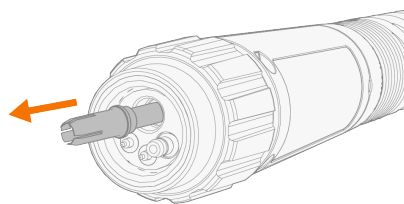
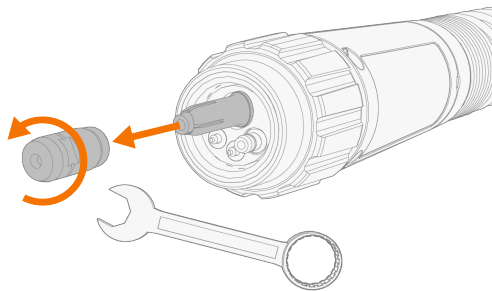

- i** The GX series 8 welding gun has a long sleeve nut and the series 8 GMN, WS and 608W models include also an additional sealing ring (*). Remove that also.

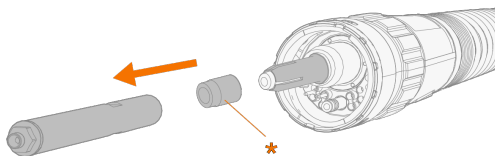

- Remove the old wire liner from the cable hose.

- !** If you still plan to use the same wire liner later, make sure not to damage the wire liner at this stage.

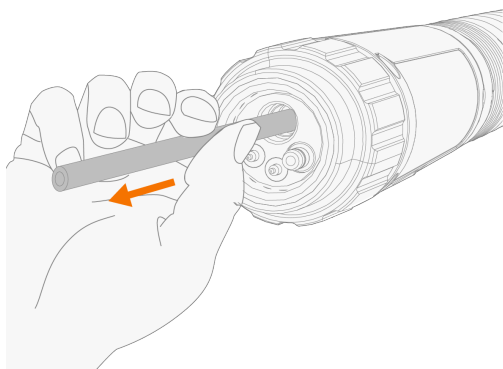

4. Feed the new wire liner into the cable hose until it stops at the gun neck end.

i The standard DL Chili wire liner includes a short metal spiral section at its front end. This metal spiral end goes in first. The DL Chili wire liner for a multi-neck welding gun does not include the metal spiral section.

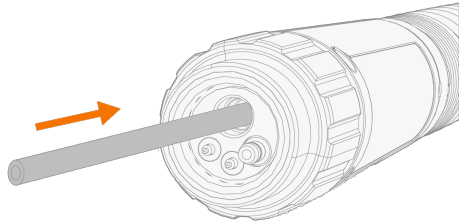

i To ensure that the wire liner is in the correct position, temporarily remove the welding gun contact tip. For more information on the contact tip, refer to "About equipment" on page 5 and "Assembling gun" on page 8. In case of a multi-neck welding gun, the wire liner does not go into the neck. With a multi-neck welding gun, the neck is to be removed (refer to "Replacing wire liner for multi-neck" on page 21).

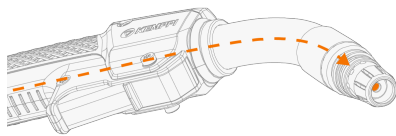

For finalizing the wire liner installation, refer to (depending on your welding gun model):

"Installing sleeve assembly and cutting wire liner (Euro connector: series 3 and series 5 welding guns)" below or

"Installing sleeve assembly and cutting wire liner (Kemppi connector: series 8 welding guns)" on the next page.

Installing sleeve assembly and cutting wire liner (Euro connector: series 3 and series 5 welding guns)

The method is the same for both gas- and water-cooled welding guns.

1. Insert the sleeve nut next to the wire liner for measure.
2. Using carpet knife, cut the wire liner flush with groove in the sleeve nut end.

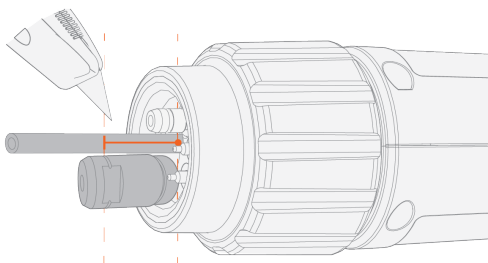

3. Insert the retainer cone onto the wire liner and push in place.

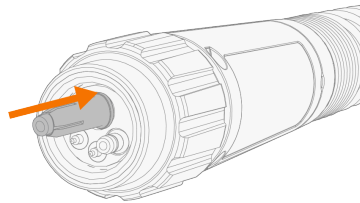

4. Place the sleeve nut on the wire liner and secure it in place. Tighten to 12 Nm torque.

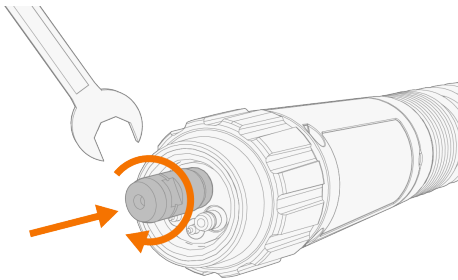

Installing sleeve assembly and cutting wire liner (Kemppi connector: series 8 welding guns)

The method is the same for both gas- and water-cooled welding guns, except for the additional sealing ring with the below-mentioned models.

1. Temporarily remove the end cap from the long sleeve nut.

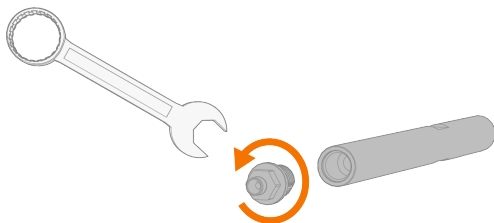

2. Insert the retainer cone and sleeve nut (without end cap) on the wire liner and secure them in place. Tighten to 12 Nm torque.



All series 8 Flexlite GX models (Kemppi connector) include a longer wire liner sleeve. The series 8 GMN, WS and 608W models include also an additional sealing ring (*):

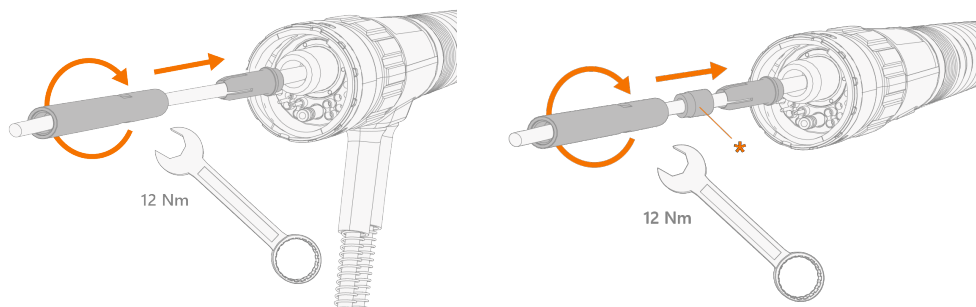

3. Cut the wire liner flush with the sleeve nut end. Use a carpet knife for cutting.

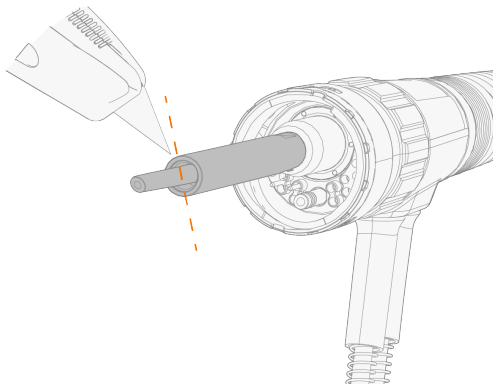

4. Install the end cap. Tighten to 1 Nm torque.

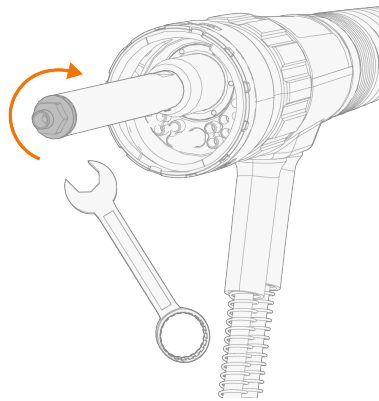

3.4.2 Replacing steel wire liner

Tools needed:

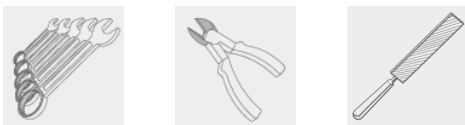

Removing and inserting wire liner

This same method applies to both Euro connector (GX series 3 and 5) and Kemppi connector (GX series 8) welding guns, but the visual details may vary. The method is the same also for both gas- and water-cooled welding guns.

1. Straighten the welding gun cable pack.

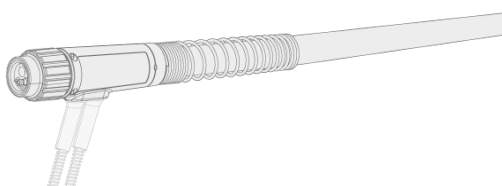

2. At the wire feeder end of the cable, remove the wire liner's sleeve nut and retainer cone.

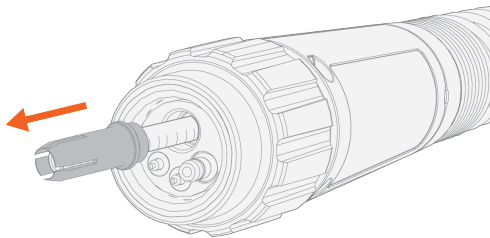
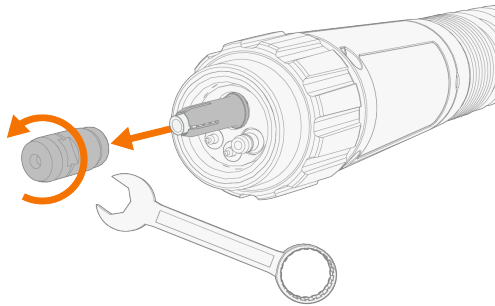

-  The GX series 8 welding gun has a long sleeve nut and the series 8 GMN, WS and 608W models include also an additional sealing ring (*). Remove that also.

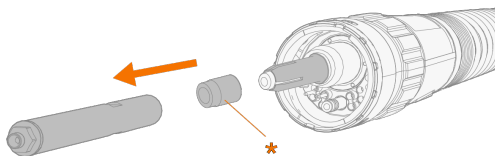

3. Remove the old wire liner from the cable hose.

-  If you still plan to use the same wire liner later, make sure not to damage the wire liner at this stage.

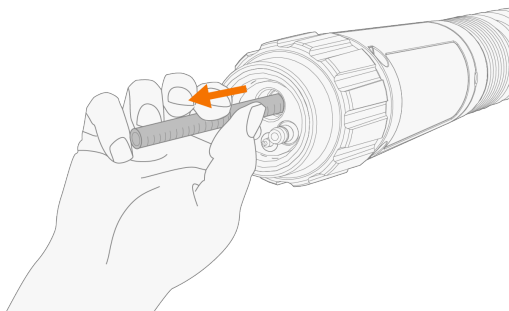

4. Feed the new wire liner into the cable hose until it stops at the gun neck end.

i The standard steel wire liner includes a stripped steel spiral section(*) at its front end. This section goes in first. The steel wire liner for a multi-neck welding gun does not include a stripped section.

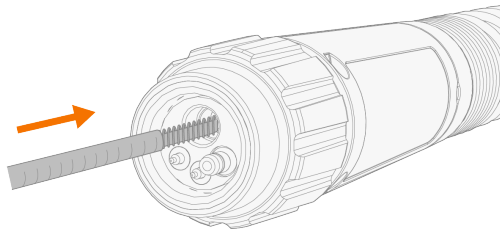

i To ensure that the wire liner is in the correct position, temporarily remove the welding gun contact tip. For more information on the contact tip, refer to "About equipment" on page 5 and "Assembling gun" on page 8. In case of a multi-neck welding gun, the wire liner does not go into the neck. With a multi-neck welding gun, the neck is to be removed (refer to "Replacing wire liner for multi-neck" on page 21).

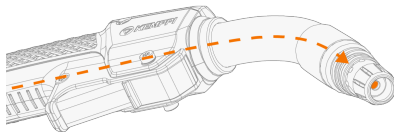

For finalizing the wire liner installation, refer to (depending on your welding gun model):

"Installing sleeve assembly and cutting wire liner (Euro connector: series 3 and 5 welding guns)" below or

"Installing sleeve assembly and cutting wire liner (Kemppei connector: series 8 welding guns)" on the next page.

Installing sleeve assembly and cutting wire liner (Euro connector: series 3 and 5 welding guns)

The method is the same for both gas- and water-cooled welding guns.

1. Insert the sleeve nut next to the wire liner for measure.
2. Using side cutting pliers, cut the wire liner flush with groove in the sleeve nut end.

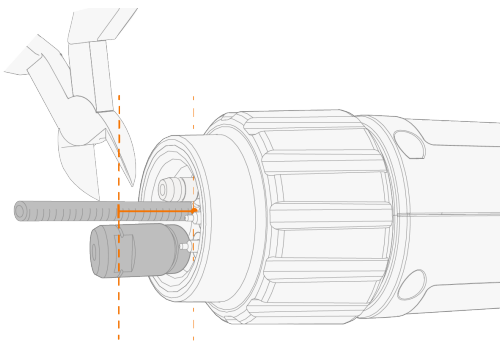

3. File the end of the liner.

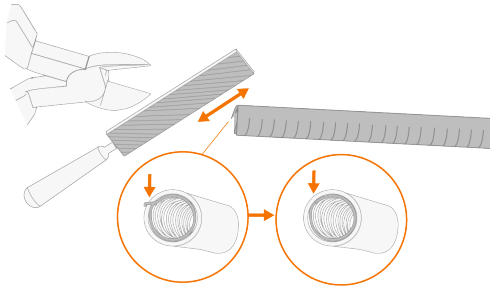

 *Don't leave any rough, inward edges that could potentially damage the filler wire.*

4. Insert the retainer cone onto the wire liner and push it in place.

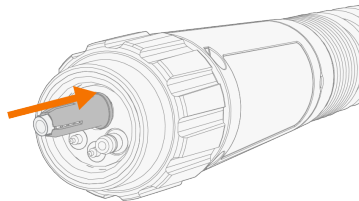

5. Place the sleeve nut on the wire liner and secure it in place. Tighten to 12 Nm torque.

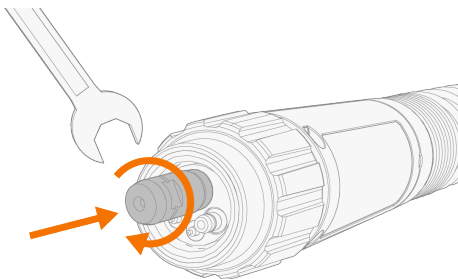

Installing sleeve assembly and cutting wire liner (Kemppi connector: series 8 welding guns)

The method is the same for both gas- and water-cooled welding guns, except for the additional sealing ring with the below-mentioned models.

1. Temporarily remove the end cap from the long sleeve nut.

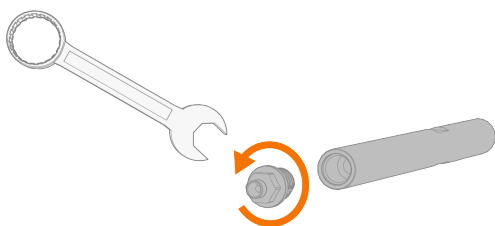

2. Insert the retainer cone and sleeve nut (without the end cap) on the wire liner and secure them in place. Tighten to 12 Nm torque.

 *Series 8 Flexlite GX models (Kemppi connector) include a longer wire liner sleeve. The series 8 GMN, WS and 608W models include also an additional sealing ring (*):*

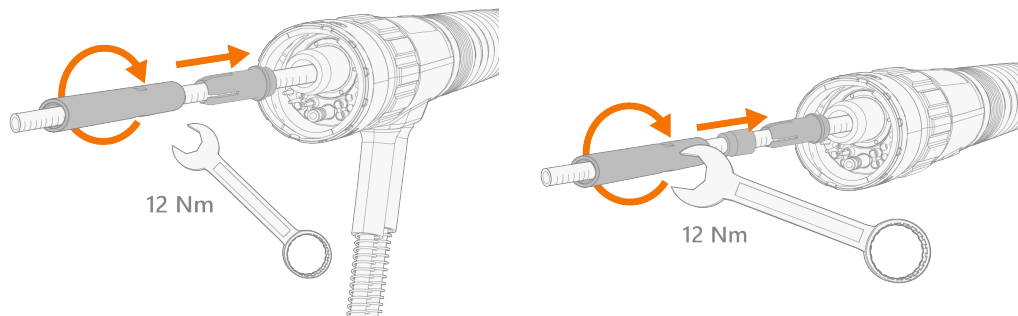

3. Cut the wire liner leaving 1-2 mm of excess liner measured from the sleeve nut end. Use side cutting pliers for cutting.

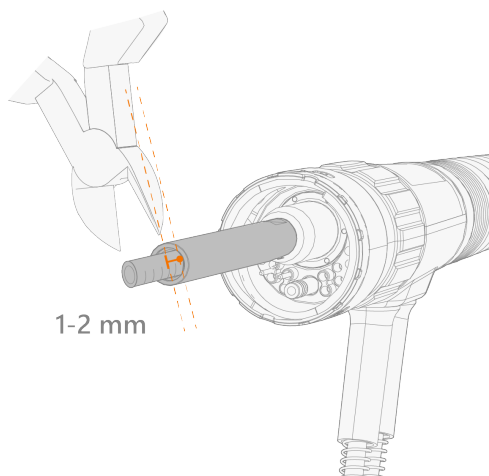

4. File the end of the liner.

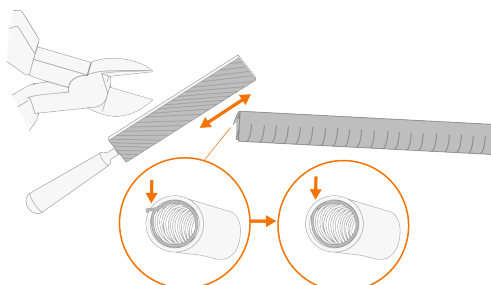

 *Don't leave any rough, inward edges that could potentially damage the filler wire.*

5. Install the end cap. Tighten to 1 Nm torque.

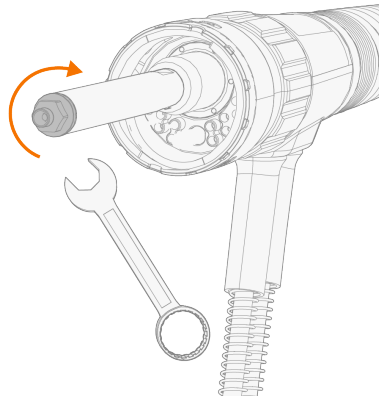

3.4.3 Replacing wire liner for multi-neck

With Flexlite GX multi-neck welding guns the wire liner needs to be replaced separately for the neck. For more information on wire liner replacement in general, refer to "Replacing steel wire liner" on page 16 and "Replacing DL Chili wire liner" on page 12.

1. Remove the neck.

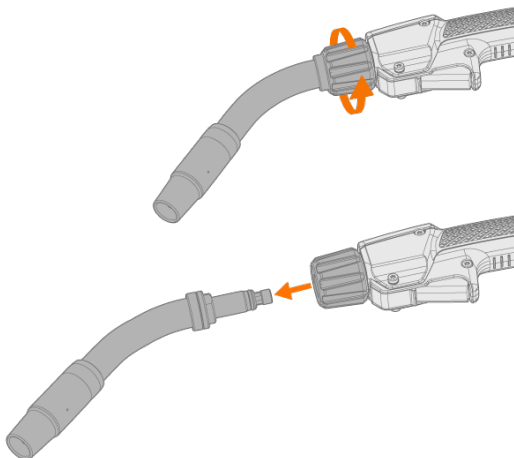

2. Release the neck liner fastener and remove the old neck wire liner.

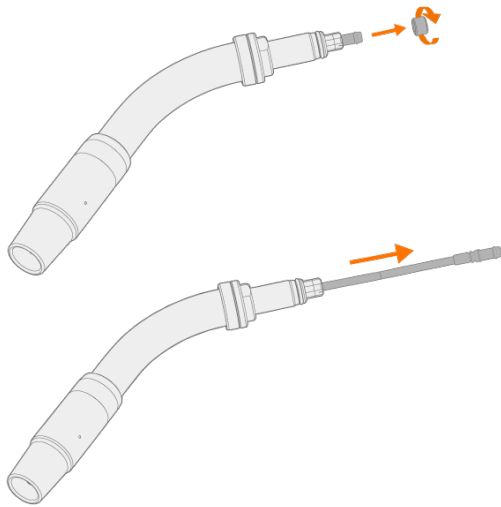

3. Insert the new neck wire liner into the neck and ensure that it goes all the way through and the liner's end(*) sits firmly in its housing. Secure with the fastener.

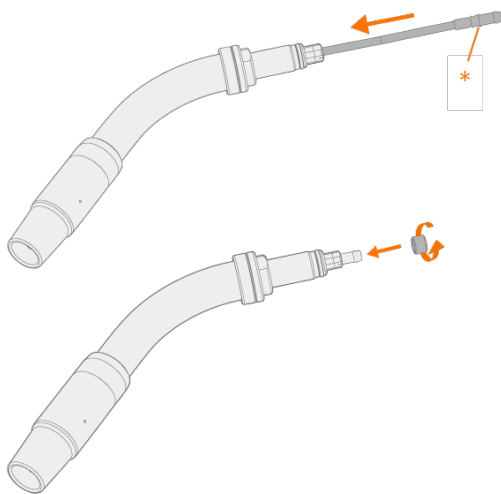

4. Attach the assembled neck to the gun body. Secure with the neck tightening collar.

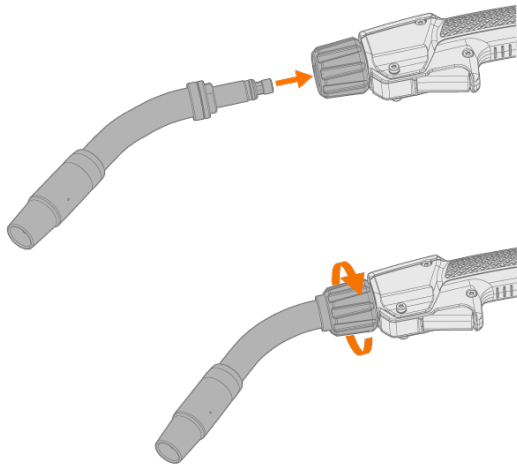

Hand-tighten only. Over-tightening and/or using a tool can damage the gun components.

3.5 Trigger switch replacement

i In normal use, the trigger switch replacement is not a frequent task. However, removing the trigger switch temporarily may be necessary, for example, when using a series 5 Flexlite GX welding gun with other than Kemppi Fast-mig equipment.

Tools needed:



TX20

1. Remove the screws holding the trigger switch in place.

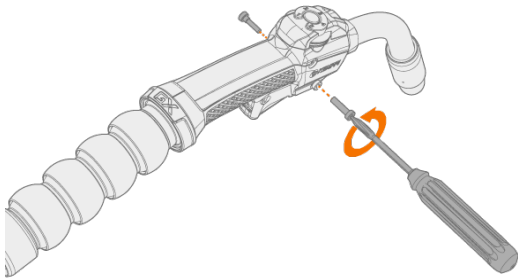

2. Slide the trigger switch slightly forward (towards the gun welding end) and pull it out.

⚠ Do not use excessive force, the trigger switch is still attached with a wiring connection underneath.

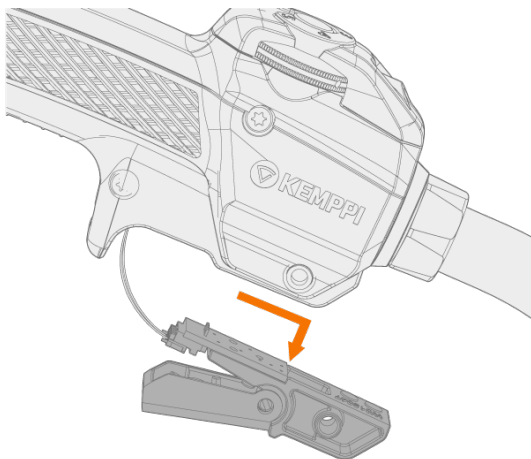

3. Disconnect the wiring connector from the trigger switch.

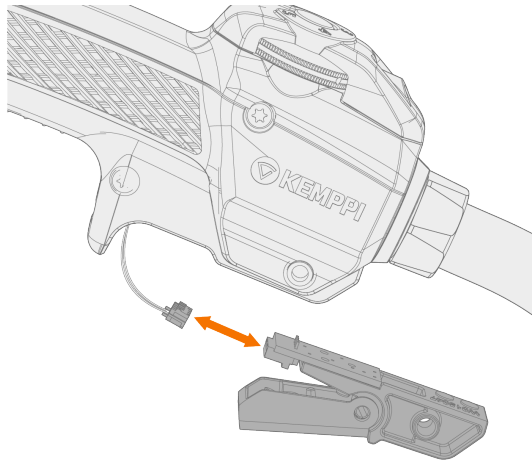

4. To reinstate the trigger switch or to install a replacement trigger switch, repeat the previous steps in reverse.



Use caution when connecting the wiring connector. Wrong alignment and/or too much force may damage the connector pins.



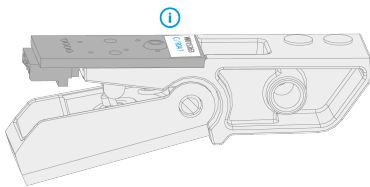

3.5.1 Trigger switch setting (GX series 5) – W015263 until 9/2020

This instruction applies to series 5 trigger switch circuit boards W015263 with the version identification **C** (9/2020) or older (e.g. A or B). Refer to the label on the circuit board for version information:



Series 5 Flexlite GX welding guns are designed and set up for Kemppi Fastmig equipment by default (circuit board W015263 until 9/2020). The secondary trigger switch setting provides only limited support for other than Kemppi Fastmig welding equipment. Use this option with caution.

Settings diagram:

Primary (default)		Secondary	
ON	ON	ON	ON
			
1	2	1	2
- Kemppi Fastmig		- Kempact Classic - Fitweld - X3 MIG Welder - Kempact RA - Other than Kemppi	

Tools needed:



TX6

For changing the setting:

1. Detach the trigger switch. Refer to "Trigger switch replacement" on page 24 for more detailed instructions.
2. Release the small screw holding the trigger switch circuit board and remove the circuit board.

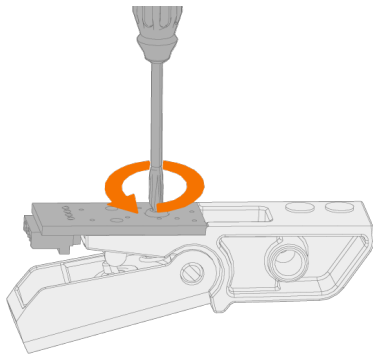

3. Set the two dip switches on the circuit board to the correct position (refer to the settings diagram above).

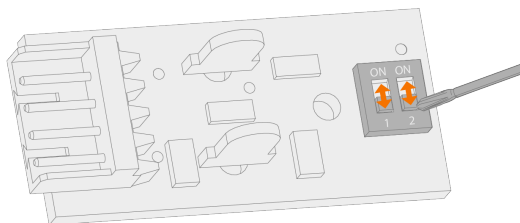

4. Reassemble and reinstate the trigger switch. Refer to "Trigger switch replacement" on page 24 for more detailed instructions.



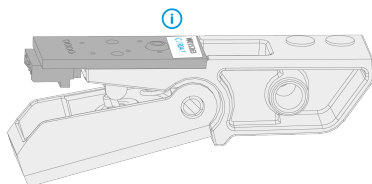

3.5.2 Trigger switch setting (GX series 5) – W015263 since 10/2020

This instruction applies to series 5 trigger switch circuit boards W015263 with the version identification **R04** (10/2020) or newer. Refer to the label on the circuit board for version information:



 *The series 5 Flexlite GX welding guns are designed and set up for Kemppi Fastmig, Pro and Kempact Pulse equipment by default (since trigger switch circuit board version R04 (10/2020)). The secondary trigger switch setting provides general support also for other than the above-mentioned Kemppi welding equipment. Use this option with caution.*

Settings diagram:

Primary (default)		Secondary	
ON	ON	ON	ON
			
1	2	1	2
- Kemppi Fastmig - Kemppi Pulse - Kemppi Pro		- Kempact Classic - Fitweld - X3 MIG Welder - Kempact RA - Other than Kemppi	

Tools needed:



TX6

For changing the setting:

1. Detach the trigger switch. Refer to "Trigger switch replacement" on page 24 for more detailed instructions.
2. Release the small screw holding the trigger switch circuit board and remove the circuit board.

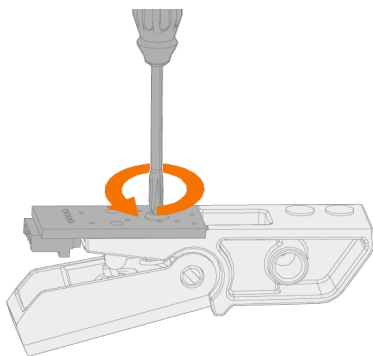

3. Set the two dip switches on the circuit board to the correct position (refer to the settings diagram above).

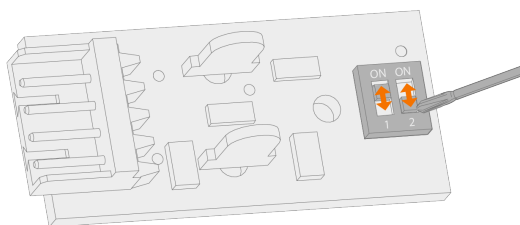

4. Reassemble and reinstate the trigger switch. Refer to "Trigger switch replacement" on page 24 for more detailed instructions.



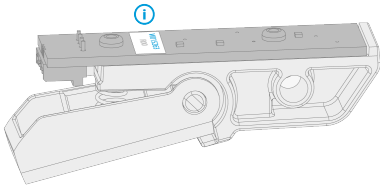

3.5.3 Trigger switch setting (GX series 5) – W022322

This instruction applies to series 5 trigger switch circuit board W022322. Refer to the label on the circuit board for version information:



The series 5 Flexlite GX welding guns are designed and set up for Kemppi Fastmig, Pro and Kempact Pulse equipment by default (trigger switch circuit board W022322). The secondary trigger switch setting provides general support also for other than the above-mentioned Kemppi welding equipment. Use this option with caution.

Settings diagram:

D1: Primary (default)		D2: Secondary	
ON	ON	ON	ON
			
1	2	1	2
<ul style="list-style-type: none"> - Kemppi Fastmig - Kempact Pulse - Kemppi Pro 		<ul style="list-style-type: none"> - Kempact Classic - Fitweld - X3 MIG Welder - Kempact RA - Other than Kemppi 	

Tools needed:



TX6

For changing the setting:

1. Detach the trigger switch. Refer to "Trigger switch replacement" on page 24 for more detailed instructions.
2. Set the two dip switches on the circuit board to the correct position (refer to the settings diagram above).

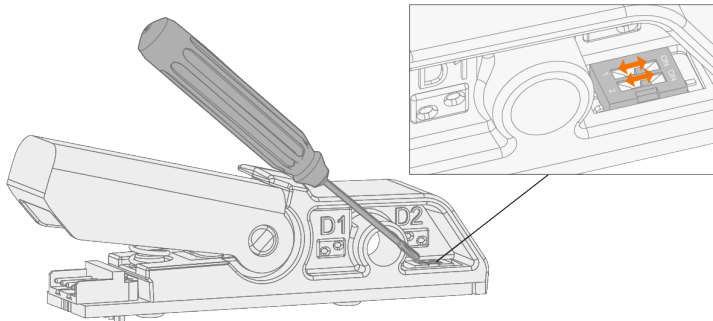

3. Reassemble and reinstate the trigger switch. Refer to "Trigger switch replacement" on page 24 for more detailed instructions.

3.6 Installing and removing grip handle (optional)

The additional grip handle is available for all Flexlite GX MIG welding guns.

1. Keeping the bottom of the grip handle pointing forward, fit the inside grooves of the grip handle over the screws on the gun.

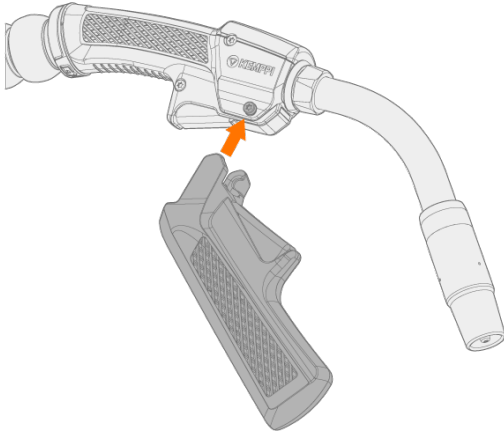

2. Pull the handle backward to lock it in position.

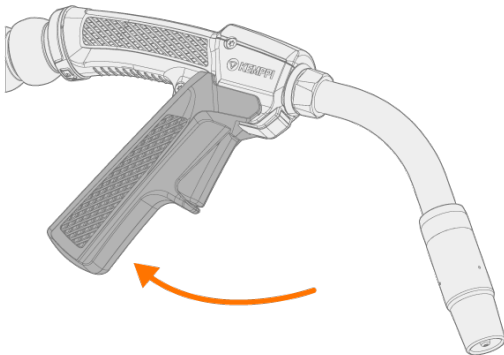

To remove the grip handle, press the unlock button in the grip handle rear:

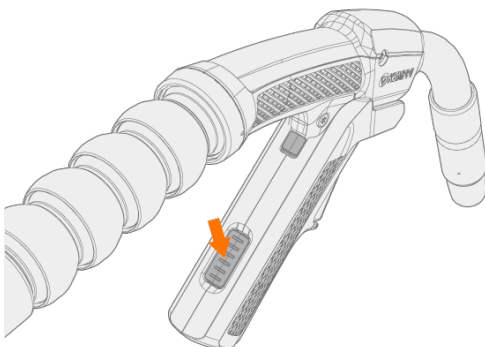



3.7 Adjusting and tightening neck (gas-cooled models)

With the gas-cooled Flexlite GX welding guns (G-models), the neck position can be adjusted.

Tools needed:



24mm



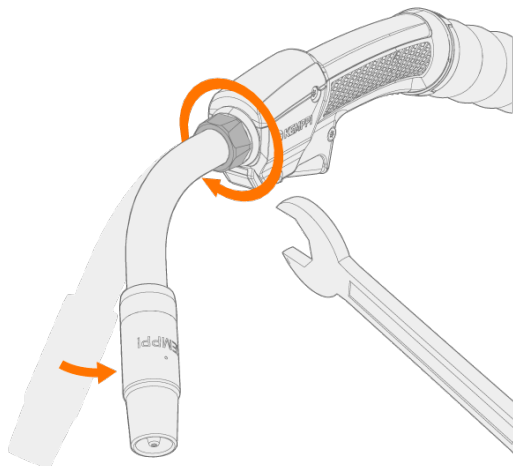

-  Do not loosen the neck retaining nut more than it is necessary to adjust the neck. Typically the neck retaining nut is tightened so that the neck is still adjustable by hand, but so that it does not accidentally shift position during welding.
-  The Flexlite GX HD models do not have a neck retaining nut. The neck is still adjustable by hand and stays in the desired position due to its design.

Tighten or loosen the neck retaining nut with a spanner so that it is either possible to adjust the neck position by hand or tighten the nut so that it secures the neck into the desired welding position.



4. OPERATION

Before using the equipment, ensure that all the necessary installation actions have been completed according to your equipment setup and instructions.

-  *Welding is forbidden in places where there is an immediate fire or explosion hazard!*
-  *Welding fumes may cause injury. Take care to ensure sufficient ventilation during welding and wear respiratory protection!*
-  *Always check before use that interconnecting cable, shielding gas hose, earth return lead/clamp and mains cable are in serviceable condition. Ensure that the connectors are correctly fastened. Loose connectors can impair welding performance and damage connectors.*
-  *The exact function of the gun and trigger may vary depending on your welding machine settings (e.g. 2T, 4T or Mini-log).*

To start welding, press the trigger switch.

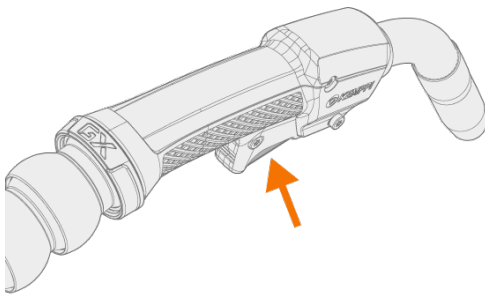

"Using gun remote GXR10 (series 5)" on the next page

"Using gun remote GXR80B (series 8)" on page 34

For more information on component selection and availability, refer to "Component selection" on page 60 and "Ordering codes" on page 62.

4.1 Using gun remote GXR10 (series 5)

 The Flexlite GX series 5 welding gun remote can be used with Kemppi Fastmig equipment only.

Adjust the wire feed speed or change the memory channel by turning the roller switch on the gun handle.

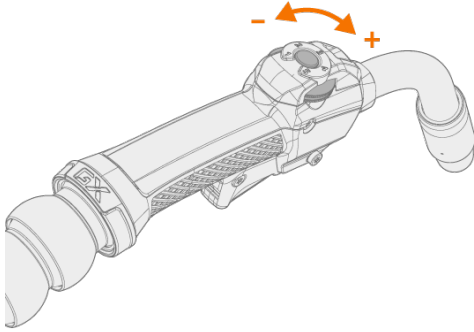

Tip: With the screw in front of the roller switch, under the rubber cap, it is possible to change the wheel's step-wise responsiveness. Fully stepless adjustment is best suited for adjusting the welding current.

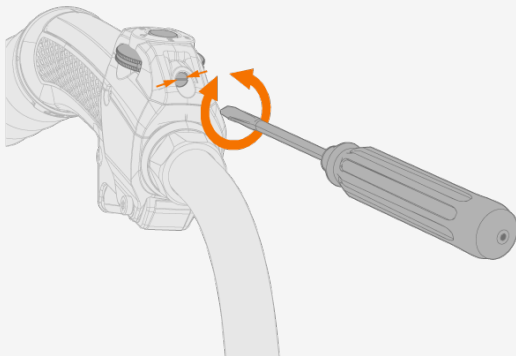

4.2 Using gun remote GXR80B (series 8)

i The Flexlite GX welding gun's GXR80B gun remote can be used with Kemppi X8 MIG Welder only.

i The remote control is disabled if TIG, MMA or gouging mode is used.

With the GXR80B remote control, you can select memory channels and adjust wire feed speed, welding current, welding voltage or voltage fine tuning depending on the welding process used.

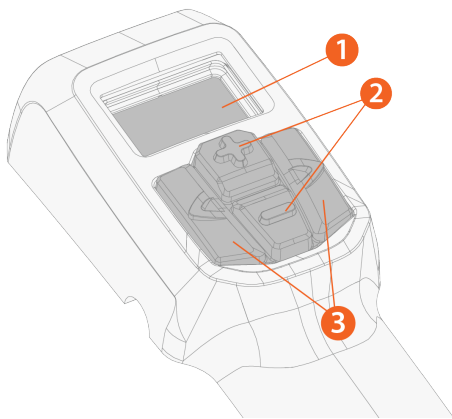

1. Custom LCD display
 - >> Displays the adjusted parameter and notifies if there is an error ("Err") in the welding system.
2. Plus/minus (+/-) buttons
 - >> Changes the parameter value or channel.
3. Left/right arrow buttons
 - >> Changes between adjustable parameters/views.

Remote control display items

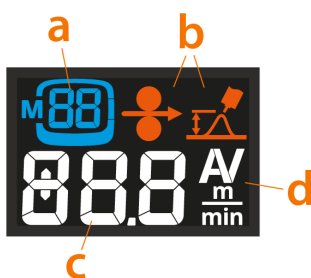

- a. Memory channel symbol and selected memory channel
- b. Wire feed speed and fine tuning symbols
- c. Adjusted parameter value (or error indicator)
- d. Adjusted parameter unit

When the parameter is adjusted with the remote and the parameter value doesn't reflect the one saved on the selected memory channel anymore, this is indicated on the display by showing only the memory channel number without the channel box around it:

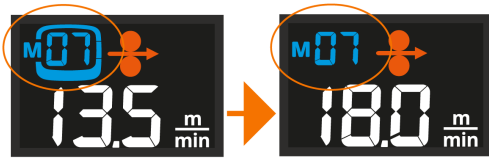

Remote control views and operation

- **Memory channel view:** The memory channel is changed by pressing the +/- buttons. Long press of a +/- button scrolls the parameter values faster. Long press of the left arrow button saves the adjusted parameters on the currently selected channel.
- **Welding power view:** Depending on the used welding process, wire feed speed or current is adjusted by pressing the +/- buttons. Long press of a +/- button scrolls the parameter values faster.
- **Fine tuning view:** Depending on the welding process used, voltage or welding process specific parameter is fine-tuned by pressing the +/- buttons. Long press of a +/- button scrolls the parameter values faster. Long press of the right arrow button switches between double pulse, double process and WP switch parameter sets, if one of these features or processes is in use.

5. MAINTENANCE

When planning routine maintenance, consider the operating frequency of the welding equipment and the working environment.

Correct operation of the welding equipment and regular maintenance helps you avoid unnecessary downtime and equipment failure. Mainly due to the high temperatures, MIG guns require regular checks and maintenance. Periodically, check the cables set for damage and ensure connections are tightened correctly.

Daily maintenance

 *Disconnect the power source from the mains power supply before handling electrical cables.*

- Check regularly that all the components are tightly fastened.
- Check that the current transfer surface on the Kemppi gun adapter is clean and unscratched, and the connector pins are straight and undamaged.
- Check the protective hose on the cable for damage.
- Check the two O-rings between the neck and the handle for wear and damage.
- Check the O-rings in the welding gun gas connector for wear and damage.

 *Only the gas-cooled gun has the O-rings.*

- Clean dust from the liner with pressurized air every time you change the wire spool, or every day during heavy use.
- Check and remove any spatter build-up from the nozzle.
- When not using the gun, keep it in the welding gun holder on the wire feeder.

For repairs, contact your Kemppi dealer.

Periodic maintenance

 *Only qualified service personnel are allowed to carry out periodic maintenance.*

Check the electrical connectors of the unit at least every six months. Clean oxidized parts and tighten loose connectors.

 *Use the correct tension torque when fastening loose parts.*

 *Do not use pressure washing devices.*

Service workshops

Kemppi Service Workshops complete the welding system maintenance according to the Kemppi service agreement.

The main aspects in the service workshop maintenance procedure are:

- Cleanup of the machine
- Maintenance of the welding tools
- Checkup of the connectors and switches
- Checkup of all electric connections
- Checkup of the power source mains cable and plug
- Repair of defective parts and replacement of defective components
- Maintenance test
- Test and calibration of operation and performance values when needed.

Find your closest service workshop at Kempfi website.

5.1 Troubleshooting

 *The problems and the possible causes listed are not definitive, but suggest some typical situations that may turn up during normal use of the welding system. For further information and assistance, contact your nearest Kemppi service workshop.*

General:

The welding system does not power up

- Check that the mains cable is plugged in properly.
- Check that the mains switch of the power source is at the ON position.
- Check that the mains power distribution is on.
- Check the mains fuse and/or the circuit breaker.
- Check that the earth return cable is connected.

The welding system stops working

- The gun may have overheated. Wait for it to cool down.
- Check that none of the cables is loose.
- The wire feeder may have overheated. Wait for it to cool down and see that the welding current cable is properly attached.
- The power source may have overheated. Wait for it to cool down and see that the cooling fans work properly and the air flow is unobstructed.

Wire feeder:

The filler wire on the spool unravels

- Check that the spool locking cover is closed.

The wire feeder does not feed the filler wire

- Check that the filler wire has not run out.
- Check that the filler wire is properly routed through the feed rolls to the wire liner.
- Check that the pressure handle is properly closed.
- Check that the feed roll pressure is adjusted correctly for the filler wire.
- Blow compressed air through the wire liner to check that it is not blocked.

Welding gun:

The wire burns into the contact tip

- Make sure the size and type of the current tip and liner are suitable for the filler wire.
- Make sure the wire liner is clean.
- Make sure the wire liner does not make any steep loops.
- Check the motor current level. If the current is too high, there may be problems in the wire liner.
- Check the tightness of the feeding rolls. Too tight feeding rolls may affect soft filler wires, such as aluminium and flux-cored wires.

The gun overheats

- Make sure the gun's neck is correctly connected to the handle: push the neck deep enough and check that the neck tightener is properly tightened.
- Make sure that the contact tip adapter is properly hand-tightened and the contact tip properly attached to it.
- Make sure that the welding parameters are within the range of the welding gun and the neck. The gun and the neck have separate limits for the maximum current; the lower one of these is the maximum current that can be used.

The gun neck overheats

- Make sure you are using original Kemppi consumable and spare parts. Incorrect spare part materials may cause the overheating of the neck.

The welding gun connector overheats

- Make sure the connector is properly connected to the wire feeder.
- Make sure the current transfer surface and the connector pins of the gun connector are clean and undamaged.

The gun vibrates too much during welding

- Check the tightness of the contact tip adapter and contact tip.
- Check the motor current.
- Check the wire liner (e.g. for dirt and to ensure that the wire liner has been cut properly).
- Check the filler wire. It must be straight and start coiling when it comes out from the contact tip. If not, check the tightness of the feeding rolls.
- Check the filler wire batch for any quality issues with the wire.

Weld quality:

Dirty and/or poor weld quality

- Check that the shielding gas has not run out.
- Check that the shielding gas flow is unobstructed.
- Check that the gas type is correct for the application.
- Check the polarity of the gun/electrode.
- Check that the welding procedure is correct for the application.

Varying welding performance

- Check that the wire feed mechanism is adjusted properly.
- Blow compressed air through the wire liner to check that it is not blocked.
- Check that the wire liner is correct for the selected wire size and type.
- Check the welding gun contact tip's size, type and wear.
- Check that the welding gun is not overheating.
- Check that the earth return clamp is properly attached to a clean surface of the workpiece.

High spatter volume

- Check the welding parameter values and welding procedure.
- Check the gas type and flow.
- Check the polarity of the gun/electrode.
- Check that the filler wire is correct for the current application.

5.2 Disposal



Do not dispose of any electrical equipment with normal waste!

In observance of WEEE Directive 2012/19/EU on waste of electrical and electronic equipment and European Directive 2011/65/EU on the restriction of the use of certain hazardous substances in electrical and electronic equipment, and their implementation in accordance with national law, electrical equipment that has reached the end of its life must be collected separately and taken to an appropriate environmentally responsible recycling facility. The owner of the equipment is obliged to deliver a decommissioned unit to a regional collection center, as per the instructions of local authorities or a Kemppi representative. By applying these European Directives you improve the environment and human health.

For more information: <https://kemp.cc/disposal-recycle>



6. TECHNICAL DATA

"Technical data: Flexlite GX 200A/250A (gas-cooled)" on the next page

"Technical data: Flexlite GX 300A/350A (gas-cooled)" on page 44

"Technical data: Flexlite GX 250A/300A (water-cooled)" on page 46

"Technical data: Flexlite GX 400A (gas-cooled)" on page 48

"Technical data: Flexlite GX 300A/400A/420A (water-cooled)" on page 50

"Technical data: Flexlite GX 500A/520A (water-cooled)" on page 52

"Technical data: Flexlite GX 600A (water-cooled)" on page 54

"Technical data: Flexlite GX HD 300A (gas-cooled)" on page 56

"Technical data: Flexlite GX HD 400A (gas-cooled)" on page 58

For component selection, refer to "Component selection" on page 60.

For ordering codes, refer to "Ordering codes" on page 62.

6.1 Technical data: Flexlite GX 200A/250A (gas-cooled)

Flexlite GX	203G / 205G	208GMN	253G / 255G
Feature	Value		
Welding process	MIG/MAG	MIG/MAG	MIG/MAG
Contact tip	M10x1	M10x1	M6
Method of guidance	Manual	Manual	Manual
Type of cooling	Air	Air	Air
Coolant max. pressure (bar)	-	-	-
Min. cooling power at 1l/min * (kW)	-	-	-
Min. flow rate (l/min)	-	-	-
Type of connection	Euro	Kemppi	Euro
Wire diameters (mm)	0.8...1.2	0.8...1.2	0.6...1.2
Load capacity:			
35% / Ar + 18% CO ₂	200 A	-	250 A
60% / Ar + 18% CO ₂	-	200 A	-
100% / Ar + 18% CO ₂	-	-	-
35% / CO ₂	-	-	-
60% / CO ₂	-	-	-
100% / CO ₂	-	-	-
Gas flow (l/min) in load capacity test	13	13	13
Filler wire diameter in load capacity test	1.0	1.0	1.0
Stick out length in load capacity test	15	15	15
Filler wire diameters (mm):			
Fe	0.8...1.2	0.8...1.2	0.6...1.2
Fe-MC/FC	0.9...1.2	0.9...1.2	0.9...1.2
Ss	0.8...1.2	0.8...1.2	0.8...1.2
Ss-MC/FC	0.9...1.2	0.9...1.2	0.9...1.2
Al	0.8...1.2	0.8...1.2	0.8...1.2
Operating temperature range	-20°C...+40°C	-20°C...+40°C	-20°C...+40°C
Storage temperature range	-40°C...+60°C	-40°C...+60°C	-40°C...+60°C
Pistol grip handle	Yes	Yes	Yes
Rotating neck	Yes	Yes	Yes
Changeable neck	No	Yes	No
Neck dimensions:			
Length x (mm) (see figure below)	117	101	114
Height y (mm) (see figure below)	80	86	65
Neck angle α (°) (see figure below)	45	50	40

Standards	IEC 60974-7	IEC 60974-7	IEC 60974-7
Gun length (m)	3.5 / 5	3.5 / 5	3.5 / 5

** Measured using the longest gun length available.*

Neck dimensions, G-models:

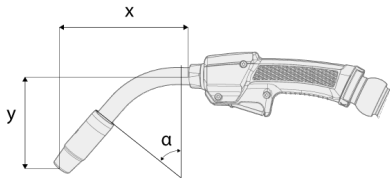

Neck dimensions, MN-models:

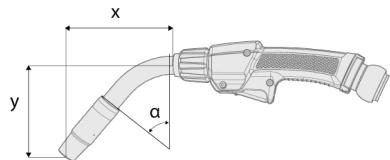

6.2 Technical data: Flexlite GX 300A/350A (gas-cooled)

Flexlite GX	303G / 305G	305GMN	305GS	308GMN
Feature	Value			
Welding process	MIG/MAG	MIG/MAG	MIG/MAG	MIG/MAG
Contact tip	M10x1	M10x1	M10x1	M10x1
Method of guidance	Manual	Manual	Manual	Manual
Type of cooling	Air	Air	Air	Air
Coolant max. pressure (bar)	-	-	-	-
Min. cooling power at 1l/min * (kW)	-	-	-	-
Min. flow rate (l/min)	-	-	-	-
Type of connection	Euro	Euro	Euro	Kemppi
Wire diameters (mm)	0.8...1.2	0.8...1.2	1.0...1.2	0.8...1.2
Load capacity:				
35% / Ar + 18% CO ₂	300 A	350 A	300 A	-
60% / Ar + 18% CO ₂	-	-	-	300 A
100% / Ar + 18% CO ₂	-	-	-	-
35% / CO ₂	-	-	-	-
60% / CO ₂	-	-	-	-
100% / CO ₂	-	-	-	-
Gas flow (l/min) in load capacity test	15	15	15	15
Filler wire diameter in load capacity test	1.2	1.2	1.2	1.2
Stick out length in load capacity test	18	18	18	18
Filler wire diameters (mm):				
Fe	0.8...1.2	0.8...1.2	-	0.8...1.2
Fe-MC/FC	0.9...1.2	0.9...1.2	-	0.9...1.2
Ss	0.8...1.2	0.8...1.2	1.0	0.8...1.2
Ss-MC/FC	0.9...1.2	0.9...1.2	-	0.9...1.2
Al	0.8...1.2	0.8...1.2	1.2	0.8...1.2
Operating temperature range	-20°C...+40°C	-20°C...+40°C	-20°C...+40°C	-20°C...+40°C
Storage temperature range	-40°C...+60°C	-40°C...+60°C	-40°C...+60°C	-40°C...+60°C
Pistol grip handle	Yes	Yes	Yes	Yes
Rotating neck	Yes	Yes	Yes	Yes
Changeable neck	No	Yes	No	Yes
Neck dimensions:				
Length x (mm) (see figure below)	138	117	138	117

Height y (mm) (see figure below)	100	97	100	97
Neck angle α (°) (see figure below)	50	50	50	50
Standards	IEC 60974-7	IEC 60974-7	IEC 60974-7	IEC 60974-7
Gun length (m)	3.5 / 5	3.5 / 5	6 / 8	3.5 / 5

** Measured using the longest gun length available.*

Neck dimensions, G-models:

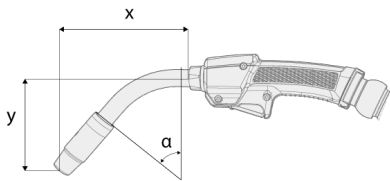

Neck dimensions, MN-models:

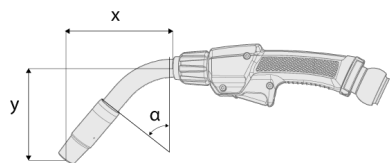

6.3 Technical data: Flexlite GX 250A/300A (water-cooled)

Flexlite GX	303W / 305W	305WS
Feature	Value	
Welding process	MIG/MAG	MIG/MAG
Contact tip	M10x1	M10x1
Method of guidance	Manual	Manual
Type of cooling	Liquid	Liquid
Coolant max. pressure (bar)	5	5
Min. cooling power at 1l/min * (kW)	0.9	0.9
Min. flow rate (l/min)	1	1
Type of connection	Euro	Euro
Wire diameters (mm)	0.8..1.6	1.0..1.6
Load capacity:		
35% / Ar + 18% CO ₂	-	-
60% / Ar + 18% CO ₂	-	-
100% / Ar + 18% CO ₂	300 A	250 A
35% / CO ₂	-	-
60% / CO ₂	-	-
100% / CO ₂	-	-
Gas flow (l/min) in load capacity test	15	15
Filler wire diameter in load capacity test	1.2	1.2
Stick out length in load capacity test	18	18
Filler wire diameters (mm):		
Fe	0.8..1.6	-
Fe-MC/FC	0.9..1.6	-
Ss	0.8..1.6	1.0..1.2
Ss-MC/FC	0.9..1.6	-
Al	0.8..1.6	1.2..1.6
Operating temperature range	-20°C...+40°C	-20°C...+40°C
Storage temperature range	-40°C...+60°C	-40°C...+60°C
Pistol grip handle	Yes	Yes
Rotating neck	No	No
Changeable neck	No	No
Neck dimensions:		
Length x (mm) (see figure below)	124	124
Height y (mm) (see figure below)	88	88
Neck angle α (°) (see figure below)	45	45

Standards	IEC 60974-7	IEC 60974-7
Gun length (m)	3.5 / 5	6

** Measured using the longest gun length available.*

Neck dimensions, W-models:

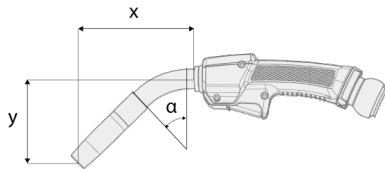

6.4 Technical data: Flexlite GX 400A (gas-cooled)

Flexlite GX	403G / 405G	408GMN
Feature	Value	
Welding process	MIG/MAG	MIG/MAG
Contact tip	M10x1	M10x1
Method of guidance	Manual	Manual
Type of cooling	Air	Air
Coolant max. pressure (bar)	-	-
Min. cooling power at 1l/min * (kW)	-	-
Min. flow rate (l/min)	-	-
Type of connection	Euro	Kemppi
Wire diameters (mm)	0.8..1.6	0.8..1.6
Load capacity:		
35% / Ar + 18% CO ₂	400 A	-
60% / Ar + 18% CO ₂	-	400 A
100% / Ar + 18% CO ₂	-	-
35% / CO ₂	-	-
60% / CO ₂	-	-
100% / CO ₂	-	-
Gas flow (l/min) in load capacity test	20	20
Filler wire diameter in load capacity test	1.6	1.6
Stick out length in load capacity test	22	22
Filler wire diameters (mm):		
Fe	0.8..1.6	0.8..1.6
Fe-MC/FC	0.9..1.6	0.9..1.6
Ss	0.8..1.6	0.8..1.6
Ss-MC/FC	0.9..1.6	0.9..1.6
Al	0.8..1.6	0.8..1.6
Operating temperature range	-20°C...+40°C	-20°C...+40°C
Storage temperature range	-40°C...+60°C	-40°C...+60°C
Pistol grip handle	Yes	Yes
Rotating neck	Yes	Yes
Changeable neck	No	Yes
Neck dimensions:		
Length x (mm) (see figure below)	156	132
Height y (mm) (see figure below)	112	110
Neck angle α (°) (see figure below)	50	50

Standards	IEC 60974-7	IEC 60974-7
Gun length (m)	3.5 / 5	3.5 / 5

** Measured using the longest gun length available.*

Neck dimensions, G-models:

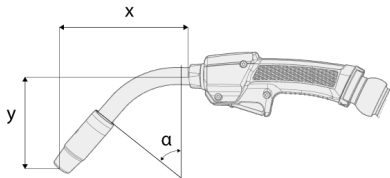

Neck dimensions, MN-models:

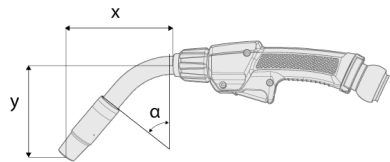

6.5 Technical data: Flexlite GX 300A/400A/420A (water-cooled)

Flexlite GX	403W / 405W	405WS	428W	428WS
Feature	Value			
Welding process	MIG/MAG	MIG/MAG	MIG/MAG	MIG/MAG
Contact tip	M10x1	M10x1	M10x1	M10x1
Method of guidance	Manual	Manual	Manual	Manual
Type of cooling	Liquid	Liquid	Liquid	Liquid
Coolant max. pressure (bar)	5	5	5	5
Min. cooling power at 1l/min * (kW)	0.9	0.9	-	-
Min. cooling power at 1.6l/min * (kW)	-	-	1.9	1.9
Min. flow rate (l/min)	1	1	1.6	1.6
Type of connection	Euro	Euro	Kemppi	Kemppi
Wire diameters (mm)	0.8...1.6	1.0...1.6	0.8...1.6	1.2...1.6
Load capacity:				
35% / Ar + 18% CO ₂	-	-	-	-
60% / Ar + 18% CO ₂	-	-	-	-
100% / Ar + 18% CO ₂	400 A	300 A	420 A	300 A
35% / CO ₂	-	-	-	-
60% / CO ₂	-	-	-	-
100% / CO ₂	-	-	-	-
Gas flow (l/min) in load capacity test	20	20	20	20
Filler wire diameter in load capacity test	1.6	1.6	1.6	1.6
Stick out length in load capacity test	22	22	22	22
Filler wire diameters (mm):				
Fe	0.8...1.6	-	0.8...1.6	-
Fe-MC/FC	0.9...1.6	-	0.9...1.6	-
Ss	0.8...1.6	1.0...1.2	0.8...1.6	1.2...1.6
Ss-MC/FC	0.9...1.6	-	0.9...1.6	-
Al	0.8...1.6	1.2...1.6	0.8...1.6	1.2...1.6
Operating temperature range	-20°C...+40°C	-20°C...+40°C	-20°C...+40°C	-20°C...+40°C
Storage temperature range	-40°C...+60°C	-40°C...+60°C	-40°C...+60°C	-40°C...+60°C
Pistol grip handle	Yes	Yes	Yes	Yes
Rotating neck	No	No	No	No
Changeable neck	No	No	No	No
Neck dimensions:				

Length x (mm) (see figure below)	134	134	132 / 232	132
Height y (mm) (see figure below)	100	100	104	104
Neck angle α (°) (see figure below)	48	48	50	50
Standards	IEC 60974-7	IEC 60974-7	IEC 60974-7	IEC 60974-7
Gun length (m)	3.5 / 5	6 / 8	3.5 / 5	8

** Measured using the longest gun length available.*

Neck dimensions, W-models:

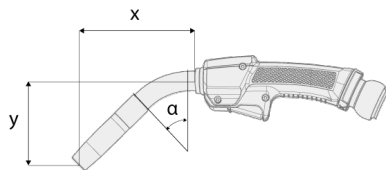

6.6 Technical data: Flexlite GX 500A/520A (water-cooled)

Flexlite GX	503W / 505W	528W
Feature	Value	
Welding process	MIG/MAG	MIG/MAG
Contact tip	M10x1	M10x1
Method of guidance	Manual	Manual
Type of cooling	Liquid	Liquid
Coolant max. pressure (bar)	5	5
Min. cooling power at 1l/min * (kW)	0.9	-
Min. cooling power at 1.6l/min * (kW)	-	1.9
Min. flow rate (l/min)	1	1.6
Type of connection	Euro	Kemppi
Wire diameters (mm)	0.8...1.6	0.8...1.6
Load capacity:		
35% / Ar + 18% CO ₂	-	-
60% / Ar + 18% CO ₂	-	-
100% / Ar + 18% CO ₂	500 A	520 A
35% / CO ₂	-	-
60% / CO ₂	-	-
100% / CO ₂	-	-
Gas flow (l/min) in load capacity test	20	20
Filler wire diameter in load capacity test	1.6	1.6
Stick out length in load capacity test	22	22
Filler wire diameters (mm):		
Fe	0.8...1.6	0.8...1.6
Fe-MC/FC	0.9...1.6	0.9...1.6
Ss	0.8...1.6	0.8...1.6
Ss-MC/FC	0.9...1.6	0.9...1.6
Al	0.8...1.6	0.8...1.6
Operating temperature range	-20°C...+40°C	-20°C...+40°C
Storage temperature range	-40°C...+60°C	-40°C...+60°C
Pistol grip handle	Yes	Yes
Rotating neck	No	No
Changeable neck	No	No
Neck dimensions:		
Length x (mm) (see figure below)	147	145 / 245
Height y (mm) (see figure below)	107	111

Neck angle α (°) (see figure below)	48	50
Standards	IEC 60974-7	IEC 60974-7
Gun length (m)	3.5 / 5	3.5 / 5

** Measured using the longest gun length available.*

Neck dimensions, W-models:

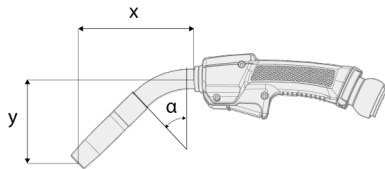

6.7 Technical data: Flexlite GX 600A (water-cooled)

Flexlite GX	605W	608W
Feature	Value	
Welding process	MIG/MAG	MIG/MAG
Contact tip	M10x1	M10x1
Method of guidance	Manual	Manual
Type of cooling	Liquid	Liquid
Coolant max. pressure (bar)	5	5
Min. cooling power at 1l/min * (kW)	0.9	-
Min. cooling power at 1.6l/min * (kW)	-	1.9
Min. flow rate (l/min)	1	1.6
Type of connection	Euro	Kemppi
Wire diameters (mm)	1.2...2.4	1.2...2.4
Load capacity:		
35% / Ar + 18% CO ₂	600 A (40%)	600 A (40%)
60% / Ar + 18% CO ₂	-	-
100% / Ar + 18% CO ₂	-	-
35% / CO ₂	-	-
60% / CO ₂	-	-
100% / CO ₂	-	-
Gas flow (l/min) in load capacity test	25	25
Filler wire diameter in load capacity test	1.6	1.6
Stick out length in load capacity test	25	25
Filler wire diameters (mm):		
Fe	1.2...2.4	1.2...2.4
Fe-MC/FC	1.2...2.4	1.2...2.4
Ss	1.2...1.6	1.2...1.6
Ss-MC/FC	1.2...1.6	1.2...1.6
Al	1.2...2.4	1.2...2.4
Operating temperature range	-20°C...+40°C	-20°C...+40°C
Storage temperature range	-40°C...+60°C	-40°C...+60°C
Pistol grip handle	Yes	Yes
Rotating neck	No	No
Changeable neck	No	No
Neck dimensions:		
Length x (mm) (see figure below)	255	251
Height y (mm) (see figure below)	74	72

Neck angle α (°) (see figure below)	30	30
Standards	IEC 60974-7	IEC 60974-7
Gun length (m)	5	5

** Measured using the longest gun length available.*

Neck dimensions, W-models:

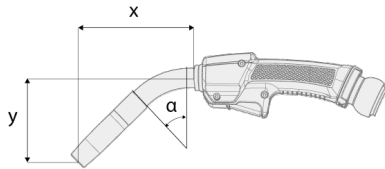

6.8 Technical data: Flexlite GX HD 300A (gas-cooled)

Flexlite GX	303GHD / 305GHD
Feature	Value
Welding process	MIG/MAG
Contact tip	M10x1
Method of guidance	Manual
Type of cooling	Air
Coolant max. pressure (bar)	-
Min. cooling power at 1l/min * (kW)	-
Min. flow rate (l/min)	-
Type of connection	Euro
Wire diameters (mm)	0.8...1.2
Load capacity:	
35% / Ar + 18% CO ₂	300 A
60% / Ar + 18% CO ₂	-
100% / Ar + 18% CO ₂	-
35% / CO ₂	-
60% / CO ₂	-
100% / CO ₂	-
Gas flow (l/min) in load capacity test	15
Filler wire diameter in load capacity test	1.2
Stick out length in load capacity test	18
Filler wire diameters (mm):	
Fe	0.8...1.2
Fe-MC/FC	0.9...1.2
Ss	0.8...1.2
Ss-MC/FC	0.9...1.2
Al	0.8...1.2
Operating temperature range	-20°C...+40°C
Storage temperature range	-40°C...+60°C
Pistol grip handle	Yes
Rotating neck	Yes
Changeable neck	No
Neck dimensions:	
Length x (mm) (see figure below)	136
Height y (mm) (see figure below)	98
Neck angle α (°) (see figure below)	50

Standards	IEC 60974-7
Gun length (m)	3.5 / 5

** Measured using the longest gun length available.*

Neck dimensions, G-models:

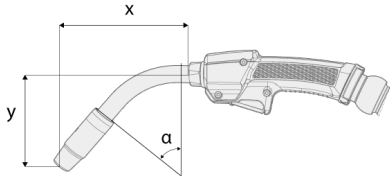

6.9 Technical data: Flexlite GX HD 400A (gas-cooled)

Flexlite GX	403GHD / 405GHD
Feature	Value
Welding process	MIG/MAG
Contact tip	M10x1
Method of guidance	Manual
Type of cooling	Air
Coolant max. pressure (bar)	-
Min. cooling power at 1l/min * (kW)	-
Min. flow rate (l/min)	-
Type of connection	Euro
Wire diameters (mm)	0.8...1.6
Load capacity:	
35% / Ar + 18% CO ₂	400 A
60% / Ar + 18% CO ₂	-
100% / Ar + 18% CO ₂	-
35% / CO ₂	-
60% / CO ₂	-
100% / CO ₂	-
Gas flow (l/min) in load capacity test	20
Filler wire diameter in load capacity test	1.6
Stick out length in load capacity test	22
Filler wire diameters (mm):	
Fe	0.8...1.6
Fe-MC/FC	0.9...1.6
Ss	0.8...1.6
Ss-MC/FC	0.9...1.6
Al	0.8...1.6
Operating temperature range	-20°C...+40°C
Storage temperature range	-40°C...+60°C
Pistol grip handle	Yes
Rotating neck	Yes
Changeable neck	No
Neck dimensions:	
Length x (mm) (see figure below)	150
Height y (mm) (see figure below)	104
Neck angle α (°) (see figure below)	50

Standards	IEC 60974-7
Gun length (m)	3.5 / 5

** Measured using the longest gun length available.*

Neck dimensions, G-models:

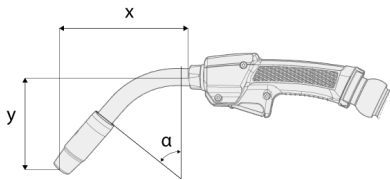

6.10 Component selection

The following table provides basic guidance regarding the Flexlite GX component compatibility.

Model	Gas nozzle	Contact tip
GX 253G	L61 / OD18 / D14 / non-threaded 	1.0C1 M6 
GX 255G		
GX 203G	L57 / OD22 / D14 / threaded 	1.0C1 M10 
GX 205G		
GX 303G	L57 / OD25 / D15 / threaded 	
GX 305G		
GX 403G	L60 / OD28 / D15 / threaded 	1.2C1 M10 
GX 405G		
GX 303W	L57 / OD22 / D14 / threaded 	1.0C1 M10 
GX 305W		
GX 403W	L57 / OD15 / D25 / threaded 	
GX 405W		
GX 503W	L60 / OD28 / D15 / threaded 	1.2C1 M10 
GX 505W		
GX 605W	L64 / OD30 / D17 / threaded 	
GX 305GMN	L57 / OD25 / D15 / threaded 	1.0C1 M10 
GX 305GS	L57 / OD25 / D15 / threaded 	1.2C1 M10 
GX 305WS	L57 / OD22 / D14 / threaded 	
GX 405WS	L57 / OD25 / D15 / threaded 	
GX 428W	L61 / OD25 / D16 / threaded 	1.0C1 M10 
GX 428W N250		
GX 208GMN	L57 / OD25 / D15 / threaded 	
GX 308GMN		

GX 528W	L64 / OD28 / D17 / threaded		1.2C1 M10	
GX 608W	L64 / OD30 / D17 / threaded			
GX 428WS	L61 / OD25 / D16 / threaded			
GX 528W N250	L64 / OD28 / D17 / threaded			
GX 408GMN	L60 / OD28 / D15 / threaded			
GX 303GHD	L61 / OD25 / D16 / threaded		1.0C1 L+ M10	
GX 305GHD				
GX 403GHD	L64 / OD28 / D17 / threaded		1.2C1 L+ M10	
GX 405GHD				

The letters in the gas nozzle specification stand for: L = length, OD = outer diameter (at the widest point), D = diameter (inner diameter of the gas nozzle tip).

In the contact tip specification: L+ = Life+ contact tip with longer life time.

7. ORDERING CODES

Tip: Letters with the product model names stand for:

W = water-cooled, G = gas-cooled, MN = multi-neck, S = long cable, HD = heavy-duty.

Flexlite GX				
Product	Ordering code			
	3.5 m:	5 m:	6 m:	8 m:
Flexlite GX 203G	GX203G35	GX203G5	-	-
Flexlite GX 205G	GX205G35	GX205G5	-	-
Flexlite GX 253G	GX253G35	GX253G5	-	-
Flexlite GX 255G	GX255G35	GX255G5	-	-
Flexlite GX 303G	GX303G35	GX303G5	-	-
Flexlite GX 303GHD	GX303GHD35	GX303GHD5	-	-
Flexlite GX 303W	GX303W35	GX303W5	-	-
Flexlite GX 305G	GX305G35	GX305G5	-	-
Flexlite GX 305GHD	GX305GHD35	GX305GHD5	-	-
Flexlite GX 305W	GX305W35	GX305W5	-	-
Flexlite GX 305GMN	GX305GMN35	GX305GMN5	-	-
Flexlite GX 305GS	-	-	GX305GS6	GX305GS8
Flexlite GX 305WS	-	-	GX305WS6	-
Flexlite GX 403G	GX403G35	GX403G5	-	-
Flexlite GX 403GHD	GX403GHD35	GX403GHD5	-	-
Flexlite GX 403W	GX403W35	GX403W5	-	-
Flexlite GX 405G	GX405G35	GX405G5	-	-
Flexlite GX 405GHD	GX405GHD35	GX405GHD5	-	-
Flexlite GX 405W	GX405W35	GX405W5	-	-
Flexlite GX 405WS	-	-	GX405WS6	GX405WS8
Flexlite GX 503W	GX503W35	GX503W5	-	-
Flexlite GX 505W	GX505W35	GX505W5	-	-
Flexlite GX 605W	-	GX605W5	-	-
Flexlite GX 208GMN	GX208GMN35	GX208GMN5	-	-
Flexlite GX 308GMN	GX308GMN35	GX308GMN5	-	-
Flexlite GX 408GMN	GX408GMN35	GX408GMN5	-	-
Flexlite GX 428W	GX428W35	GX428W5	-	-
Flexlite GX 428WS	-	-	-	GX428WS8
Flexlite GX 528W	GX528W35	GX528W5	-	-

Flexlite GX 608W	-	GX608W5	-	-
Flexlite GX 428W (250 mm neck)	GX428W35N250	GX428W5N250	-	-
Flexlite GX 528W (250 mm neck)	GX528W35N250	GX528W5N250	-	-

Flexlite GX remotes (optional)	
Product	Ordering code
GXR10 gun remote, series 5	GXR10
GXR80B gun remote, series 8	GXR80B