

FLEXLITE GXE

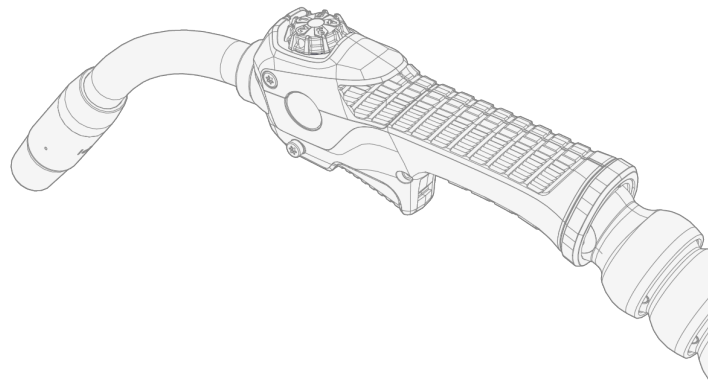

CONTENTS

1. General	3
2. Safety	5
3. About equipment	6
4. Installation	8
4.1 Assembling torch	9
4.2 Installing torch remote control GRe50	10
4.3 Installing torch remote control GRe80	12
4.4 Connecting torch	14
4.5 Installing and replacing wire liner	15
4.5.1 Replacing DL Chili wire liner	15
4.5.2 Replacing steel wire liner	19
4.5.3 Replacing wire liner for multi-neck	22
4.6 Installing additional gun handle and heat protector (optional)	24
5. Operation	26
5.1 Using torch remote GRe50 (series 3 and 5)	27
5.2 Using torch remote GRe80 (series 8)	28
6. Maintenance	30
6.1 Troubleshooting	32
6.2 Disposal	34
7. Technical data	35
7.1 Technical data: Flexlite GXe 200A (gas-cooled)	36
7.2 Technical data: Flexlite GXe 300A (gas-cooled)	42
7.3 Technical data: Flexlite GXe 400A (gas-cooled)	48
7.4 Technical data: Flexlite GXe 300A (water-cooled)	56
7.5 Technical data: Flexlite GXe 400A (water-cooled)	61
7.6 Technical data: Flexlite GXe 500A (water-cooled)	67
7.7 Component selection	71
8. Ordering information	72

1. GENERAL

These instructions describe the use of Kemppi's Flexlite GXe MIG/MAG welding torches. Flexlite GXe welding torches are designed for professional manual welding. Flexlite GXe range covers both water-cooled (W) and gas-cooled (G) models for MIG welding. Flexlite GXe welding torches are available in model series 3, 5 and 8 – all incorporating Euro welding connectors.

The series 8 Flexlite GXe welding torches include also an additional control cable connection for trigger and remote controls. The series 8 GXe torches can be used with X5 FastMig and Master M (350 models) welding equipment only.

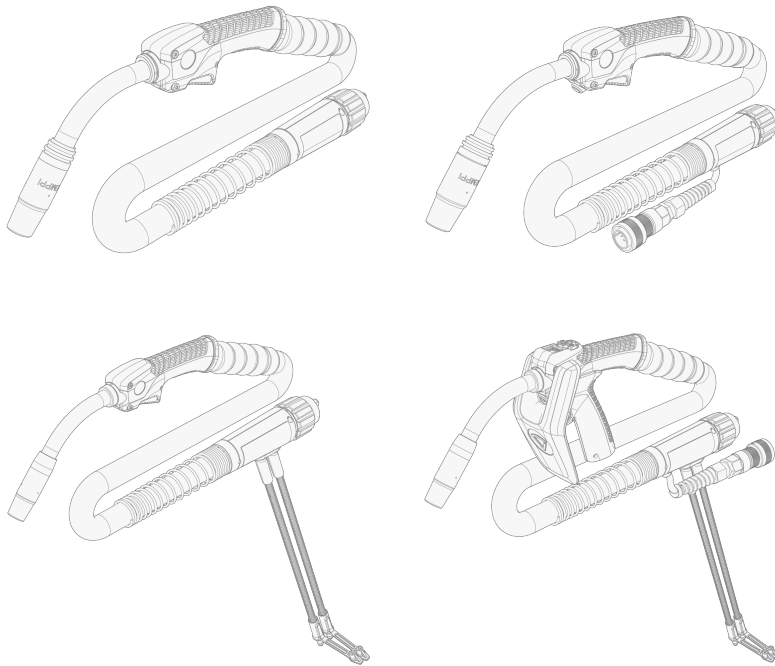

Flexlite GXe models		
Series 3:	Series 5:	Series 8:
GXe 223G3	GXe 205G35	GXe 308GA35
GXe 223G35	GXe 205G5	GXe 308GA5
GXe 223G5	GXe 305G35	GXe 408GA35
GXe 253G35	GXe 305G5	GXe 408GA5
GXe 253G5	GXe 305G6	GXe 308WA35
GXe 323G35	GXe 405G35	GXe 308WA5
GXe 323G5	GXe 405G5	GXe 408WA35
GXe 403GMN35	GXe 305W35	GXe 408WA5
GXe 403GMN5	GXe 305W5	GXe 408WA8
GXe 423G35	GXe 305W6	GXe 408GAMN35
GXe 423G5	GXe 405W35	GXe 408GAMN5
	GXe 405W5	GXe 508WA35
	GXe 405W6	GXe 508WA5

	GXe 405W8	
	GXe 505W35	
	GXe 505W5	

In model names: G = gas-cooled, W = water-cooled, MN = multi-neck, A = Additional control cable connection (Amphenol connector). The number at the end of the model name indicates the welding torch length (3 m / 3.5 m / 5 m / 6 m / 8 m).

Important notes

Read the instructions through carefully.

Items in the manual that require particular attention in order to minimize damage and harm are indicated with the below symbols. Read these sections carefully and follow their instructions.



Note: Gives the user a useful piece of information.



Caution: Describes a situation that may result in damage to the equipment or system.



Warning: Describes a potentially dangerous situation. If not avoided, it will result in personal damage or fatal injury.

[General notices](https://kemp.cc/ud/notices)

<https://kemp.cc/ud/notices>

[EULA \(End User License Agreement\)](https://kemp.cc/ud/eula)

<https://kemp.cc/ud/eula>

[Warranty](https://kemp.cc/ud/warranty)

<https://kemp.cc/ud/warranty>

DISCLAIMER

While every effort has been made to ensure that the information contained in this guide is accurate and complete, no liability can be accepted for any errors or omissions. Kemppe reserves the right to change the specification of the product described at any time without prior notice. Do not copy, record, reproduce or transmit the contents of this guide without prior permission from Kemppe.

The source language for this document is English. All other language versions available are either professional human translations or advanced machine translations. Any feedback regarding translation terminology can be sent to userdoc@kemppe.com.

Other links

Kemppe symbols: [Userdoc](#).

2. SAFETY

Welding is always classified as hot work, and welding equipment typically contains high-voltage circuits. If you are not familiar with welding and welding principles, it is recommended that you acquire welding training or professional guidance before commencing welding. The welding equipment mentioned in this manual is intended for professional use in an industrial environment.

 *For your own safety, and that of your working environment, pay particular attention to the safety instructions delivered with the equipment.*

You can also access and download the safety instructions by using these links:

- [Safety](#)

(<https://kemp.cc/safety/general>)

- [Personal protection](#)

(<https://kemp.cc/safety/ppe>)

- [Welding torches](#)

(<https://kemp.cc/safety/torches>)

3. ABOUT EQUIPMENT

The Flexlite GXe MIG welding torch equipment consists of:

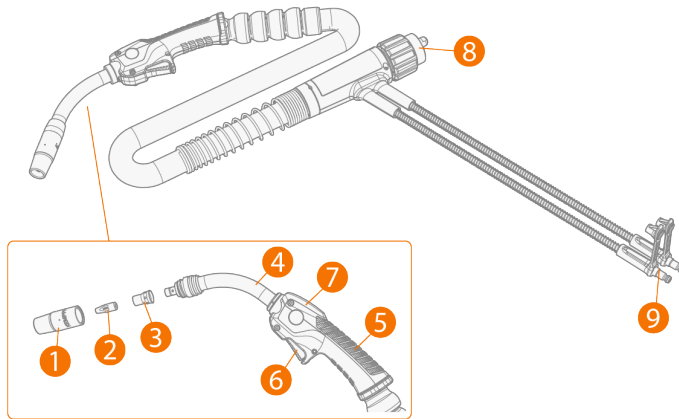

 *The exact visual details may be different between different Flexlite GXe models.*

1. Gas nozzle
2. Contact tip
3. Contact tip adapter / gas diffuser
4. Torch neck
5. Handle
6. Trigger switch
7. Cover plate or torch remote
 - >> Cover plate covers the handle if a welding torch remote is not installed (Flexlite GXe series 5 models). For more information on the torch remotes, refer to "Installing torch remote control GRe50" on page 10.
8. Torch connector
9. Coolant inlet and outlet hose connectors
 - >> With water-cooled welding torches only.

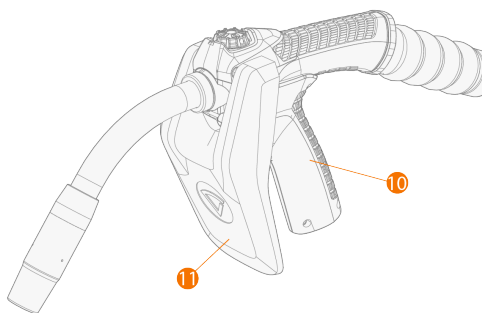

10. Additional gun handle (optional)
11. Additional heat protector (optional)

Series 8 GXe only:

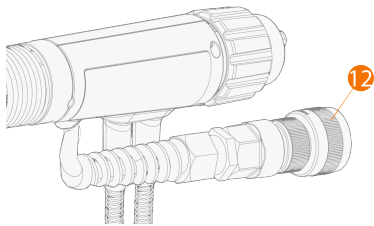

12. Additional control cable connection (Amphenol connector)

>> To be used with X5 FastMig and Master M 350 series welding equipment.

Multi-neck welding torches only:

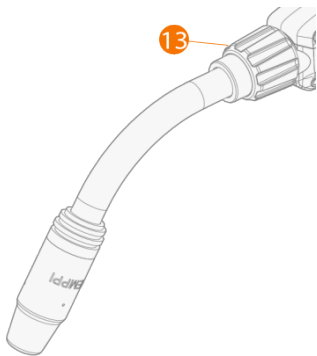

13. Neck tightening collar

Optional accessories

- GRe50 torch remote control
- Heat protector for hand protection
- Mechanical safety control switch to prevent accidental trigger action and ignitions (not compatible with the additional gun handle or the Flexlite GXe 223G and 253G welding torch models):

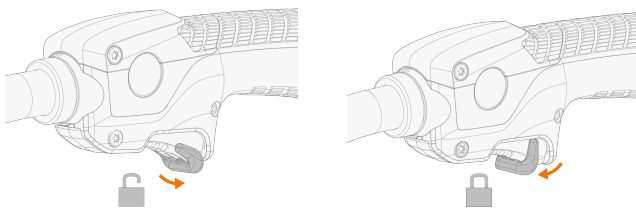

EQUIPMENT IDENTIFICATION

Quick Response (QR) code

Device-related information or a web link to such information may be found in the form of a QR code on the device. The code can be read, for example, with a mobile device camera and a QR code application.

4. INSTALLATION



Ensure that the welding equipment is not connected to the mains or that the welding torch is not connected to the welding machine until the installation is complete.



Protect the equipment from rain and direct sunshine.

"Assembling torch" on the next page

"Installing torch remote control GRe50" on page 10

"Connecting torch" on page 14

"Installing and replacing wire liner" on page 15

"Installing additional gun handle and heat protector (optional)" on page 24

Before installation and use

Ensure compliance with your local and national safety requirements regarding the installation and use of high voltage units.

Check the contents of the packages and make sure the parts are not damaged.

4.1 ASSEMBLING TORCH

 For the correct components, refer to "Component selection" on page 71.

Tools needed:



8mm

1. Attach the contact tip adapter and hand-tighten it firmly in place. It is important to tighten the adapter properly to enable a tight connection of the contact tip to the torch.
2. Attach the contact tip and secure it with spanner.
3. Attach the gas nozzle and hand-tighten it firmly in place.

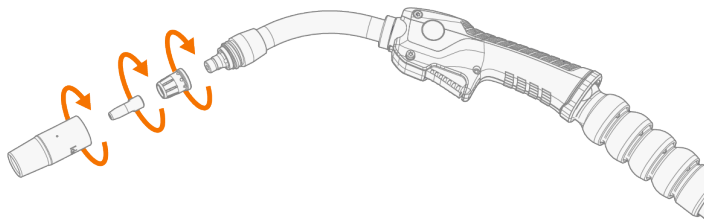

Multi-neck welding torches only:

4. Attach the assembled neck to the welding torch body. Secure with the neck tightening collar.
-  *Hand-tighten the neck tightening collar only. Over-tightening and/or using a tool can damage the torch components.*

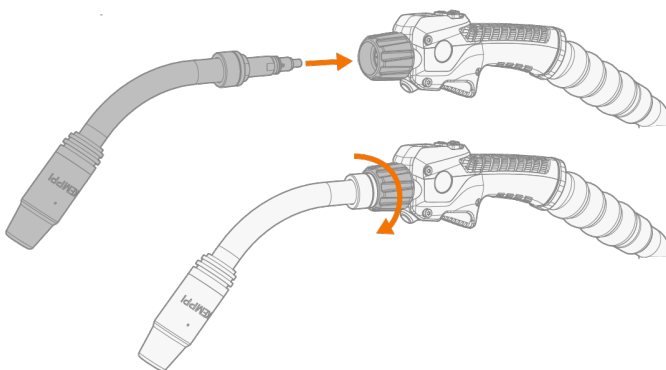

4.2 INSTALLING TORCH REMOTE CONTROL GRE50

i The Flexlite GXe series 5 welding torch remote (GRe50) is available as an optional accessory for series 3 and series 5 GXe welding torches, except Flexlite GXe 223G3. GRe50 is not compatible with series 8 GXe welding torches.

! Ensure that the welding equipment is not connected to the mains or that the welding torch is not connected at this stage.

Tools needed:



TX20

1. Remove the cover by releasing the screws on the sides and then moving the cover slightly forward and up.

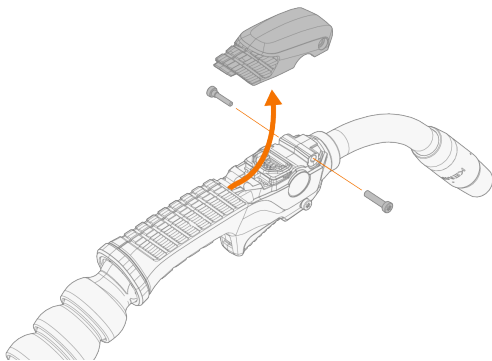

2. First set the torch remote control rear into the groove on the torch body and then press the remote control fully in place so that the connectors align.

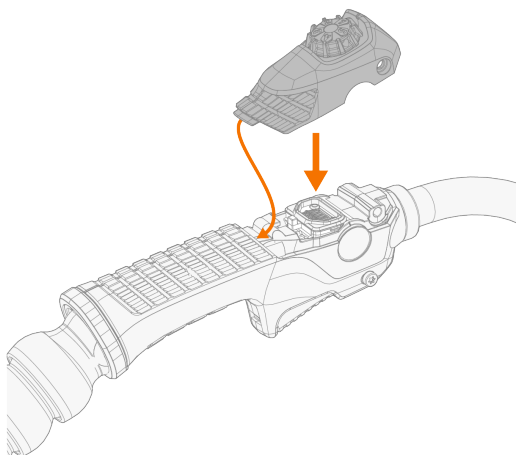

3. Secure the remote control cover in place with the screws from the sides.

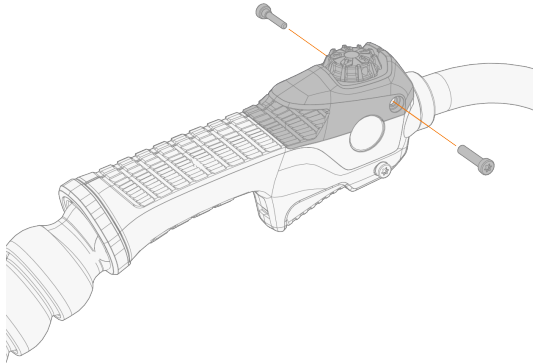

4.3 INSTALLING TORCH REMOTE CONTROL GRE80

i With the Flexlite GXe series 8 welding torches the torch remote GRe80 is delivered with the welding torch. Before welding, the temporary protection plate must be removed from the welding torch and the torch remote installed. The series 8 GXe welding torches incorporate the use of the additional control cable with X5 FastMig and Master M (350 models) welding equipment. The series 8 welding torch remote does not work with series 5 welding torches.

⚠ Ensure that the welding equipment is not connected to the mains or that the welding torch is not connected at this stage.

Tools needed:



TX20

1. Remove the cover by releasing the screws on the sides and then moving the cover slightly forward and up.

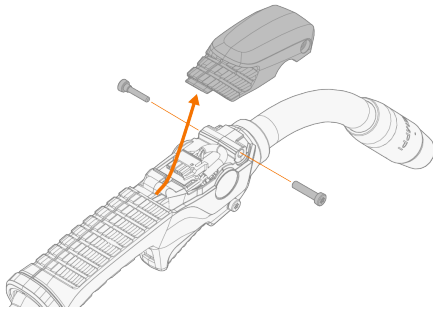

2. Attach the connection cable between the torch body and the torch remote control.

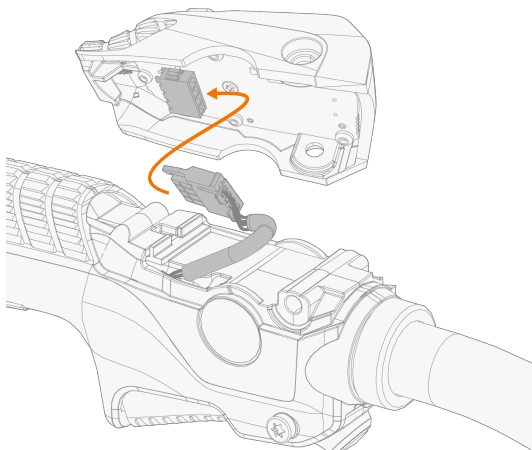

3. First set the torch remote control rear into the groove on the torch body and then press the remote control in place.

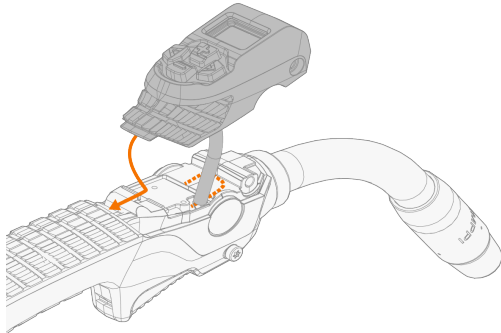

 *Ensure that the cable sets neatly under the remote control cover and that it doesn't get caught between any sharp edges.*

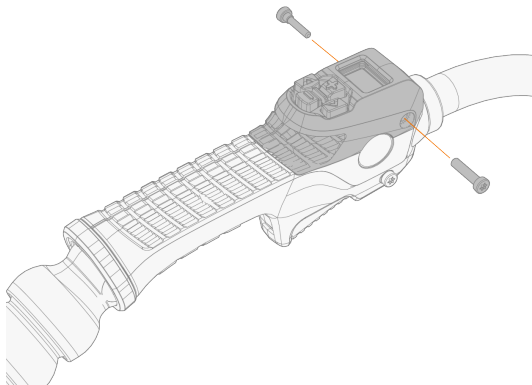

4. Secure the remote control cover in place with the screws from the sides.



4.4 CONNECTING TORCH

-  *Hand-tighten the torch connectors. Loose connectors may overheat, create contact disturbances, mechanical damage and water or gas leakage.*
-  *For connecting the torch (and applicable extension parts), refer also to your welding equipment's instructions.*
-  *If not already preinstalled, the wire liner must be installed before connecting the torch. Refer to "Installing and replacing wire liner" on the next page for instructions.*

1. Connect the torch to your welding equipment. Secure the connector in place by turning the collar clockwise.

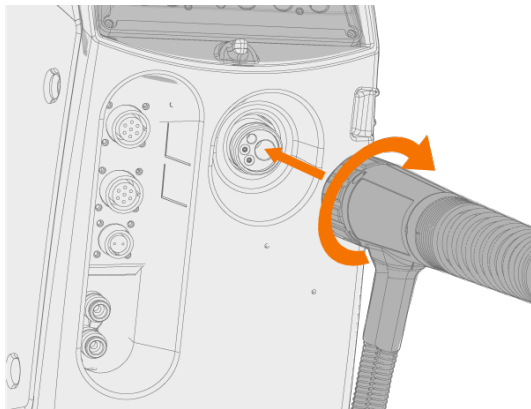

2. Water-cooled models only: Connect the coolant inlet and outlet hoses to your welding equipment. Note that the connectors are color-coded.

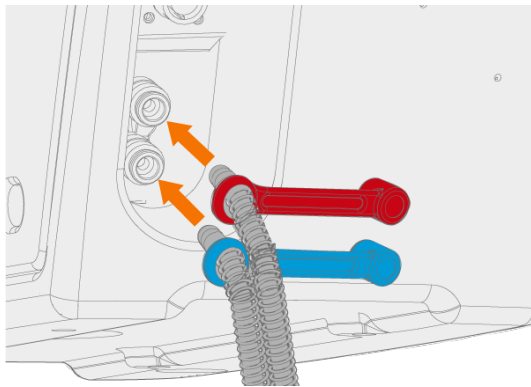

-  *Make sure to connect the coolant hoses to the correct hose connectors. If the connections cross, the welding torch may overheat.*
3. Flexlite GXe series 8 welding torches only: Connect the control cable to your X5 FastMig or Master M (350 models) welding equipment's control connector.

Refer to your welding equipment's operating instructions for more information on its connection features.



4.5 INSTALLING AND REPLACING WIRE LINER

The 3 m, 3.5 m and 5 m Flexlite GXe welding torches are delivered with the wire liner preinstalled. The user must install the wire liner to the 6 m and 8 m Flexlite GXe welding torches. Refer to this section when the wire liner needs to be replaced or when taking a 6 m or 8 m Flexlite GXe welding torch model in use.

The wire liner is a consumable part, which needs to be changed if worn and when the filler wire material changes.

For replacing the steel wire liner, refer to "Replacing steel wire liner" on page 19.

For replacing the DL Chili wire liner, refer to "Replacing DL Chili wire liner" below.

-  *If you change the filler wire to a different diameter or material, change also the feed rolls in the wire feed system accordingly.*
-  *With most of the 3 m, 3.5 m and 5 m Flexlite GXe welding torch models both steel wire liner and DL Chili wire liner can be used. With the 6 m and 8 m Flexlite GXe welding torch models the DL Chili wire liner is recommended to be used.*
-  *The filler wire must be removed before the wire liner replacement. Always read the instructions delivered with the replacement wire liner as well.*

4.5.1 REPLACING DL CHILI WIRE LINER

Tools needed:



Removing and inserting wire liner

The visual details may vary slightly between different welding torch models. The method is the same for both gas- and water-cooled welding torches.

1. Straighten the welding torch cable.



- At the wire feeder end of the cable, remove the wire liner's sleeve nut.

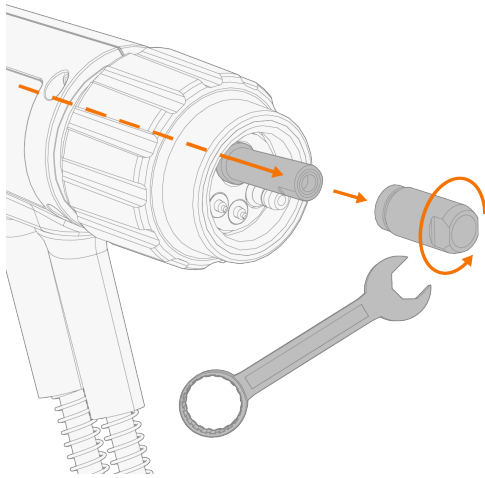

- Remove the old wire liner from the cable hose.

 *If you still plan to use the same wire liner later, make sure not to damage the wire liner at this stage.*

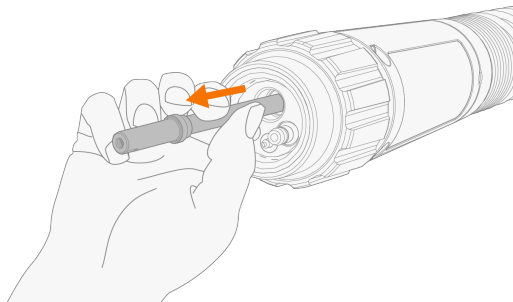

- Feed the new wire liner into the cable hose until it stops at the torch neck end.

 *The standard DL Chili wire liner includes a short metal spiral section at its front end. This metal spiral end goes in first.*

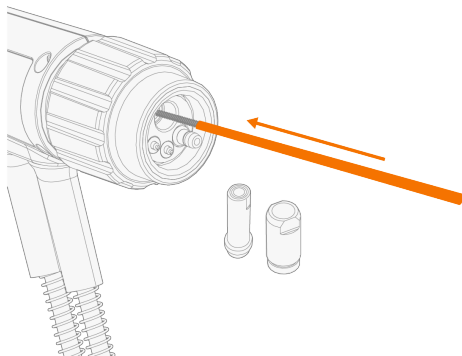

- i** To ensure that the wire liner is in the correct position, temporarily remove the welding torch contact tip. For more information on the contact tip, refer to "About equipment" on page 6 and "Assembling torch" on page 9.

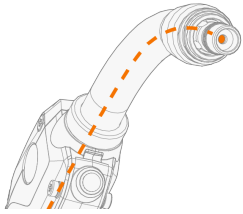

- i** In case of a multi-neck welding torch, the wire liner does not go into the neck. To ensure that the wire liner is in the correct position, temporarily remove the neck. For more information on assembling the multi-neck welding torch, refer to "Assembling torch" on page 9.

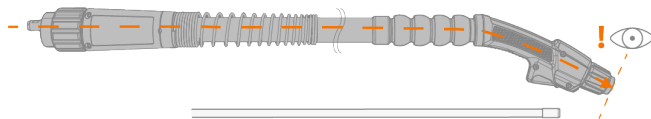

- 5.** Insert the sleeve nut next to the wire liner for measure. (Do not install the sleeve nut in its actual position at this stage.)

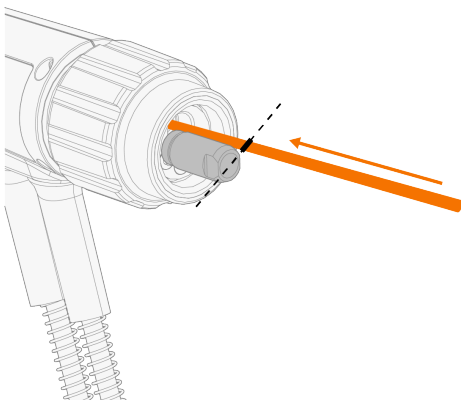

- Using carpet knife, cut the wire liner flush with the sleeve nut end.

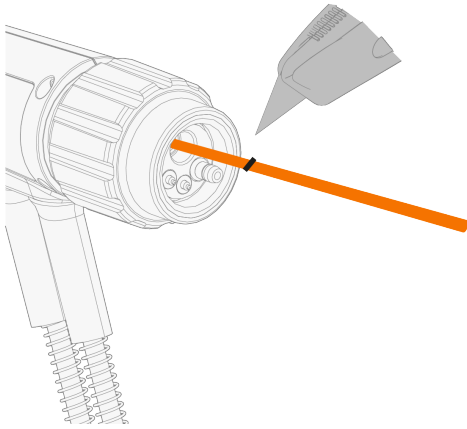

- Insert the retainer cone onto the wire liner and push in place. Ensure that the wire liner goes all the way into the tip of the retainer cone.

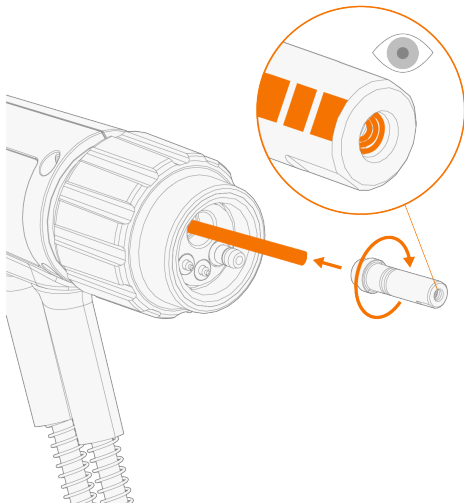

- Place the sleeve nut on the wire liner and secure it in place by tightening it to 5 Nm torque.

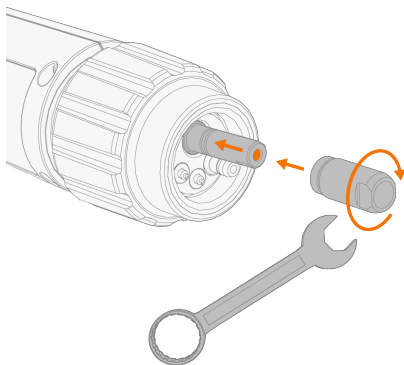

4.5.2 REPLACING STEEL WIRE LINER

Tools needed:

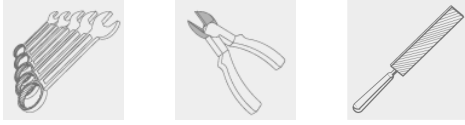

Removing and inserting wire liner

The visual details may vary slightly between different welding torch models. The method is the same for both gas- and water-cooled welding torches.

1. Straighten the welding torch cable.



2. At the wire feeder end of the cable, remove the wire liner's sleeve nut.

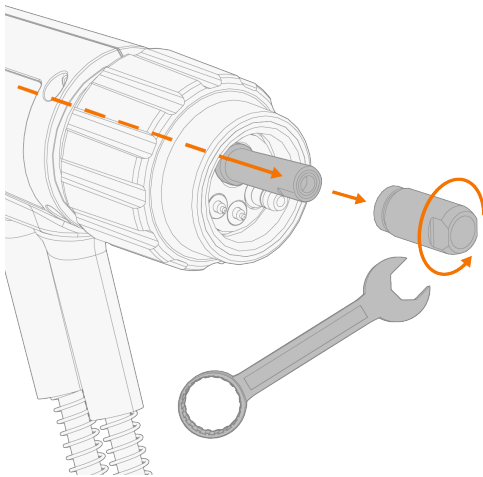

3. Remove the old wire liner from the cable hose.

 *If you still plan to use the same wire liner later, make sure not to damage the wire liner at this stage.*

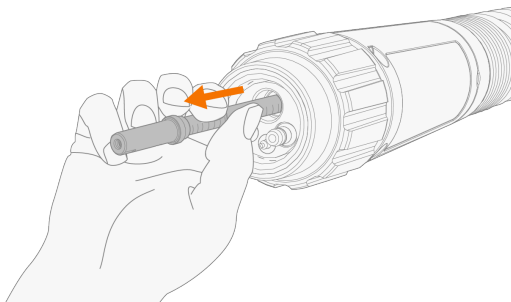

4. Feed the new wire liner into the cable hose until it stops at the torch neck end.

i The standard steel wire liner includes a stripped steel spiral section (*) in the welding torch end. This longer stripped section goes in first.

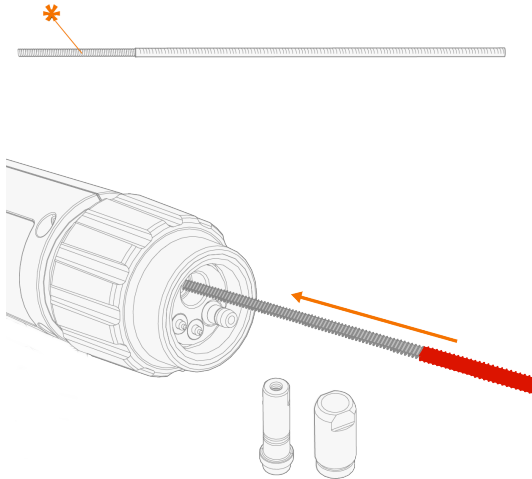

i To ensure that the wire liner is in the correct position, temporarily remove the welding torch contact tip. For more information on the contact tip, refer to "About equipment" on page 6 and "Assembling torch" on page 9.

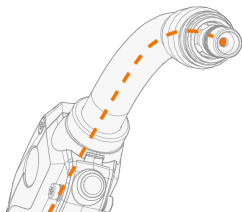

i In case of a multi-neck welding torch, the wire liner does not go into the neck. To ensure that the wire liner is in the correct position, temporarily remove the neck. For more information on assembling the multi-neck welding torch, refer to "Assembling torch" on page 9.

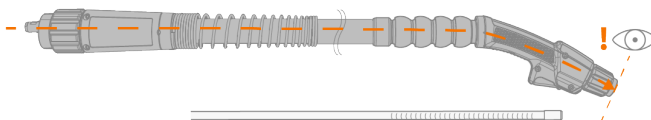

5. Insert the sleeve nut next to the wire liner for measure. (Do not install the sleeve nut in its actual position at this stage.)

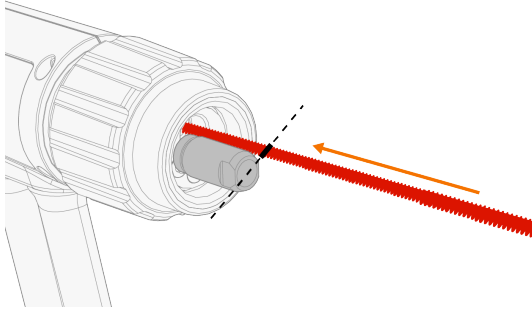

6. Using side cutting pliers, cut the wire liner flush with sleeve nut end.

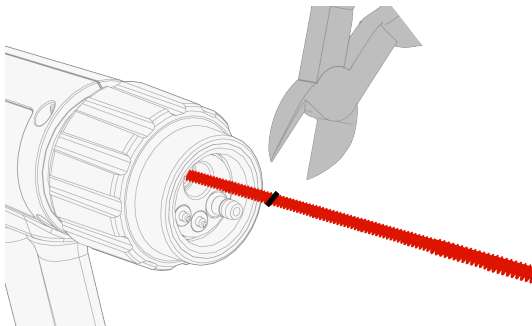

7. File the end of the wire liner.

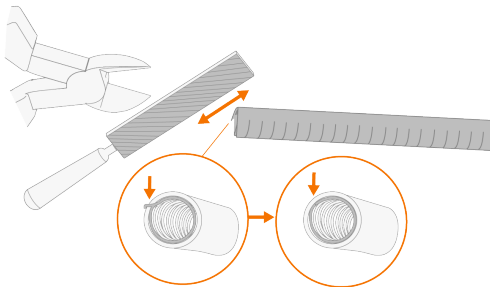

 *Don't leave any rough, inward edges that could potentially damage the filler wire.*

8. Strip the end of the wire liner for approximately 10...20 mm.

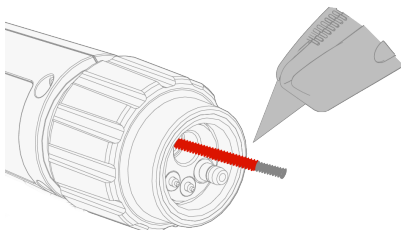

9. Insert the retainer cone onto the wire liner and push it in place. Ensure that the wire liner goes all the way into the tip of the retainer cone.

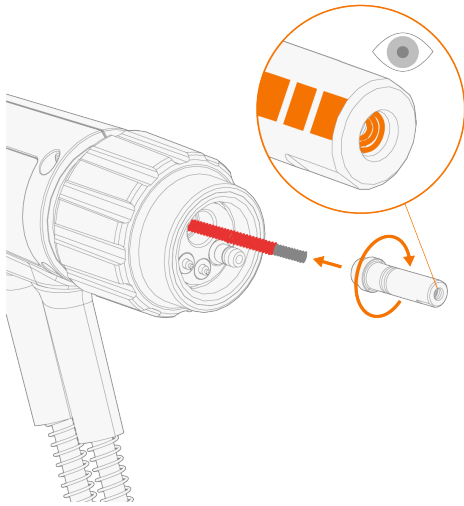

10. Place the sleeve nut on the wire liner and secure it in place by tightening it to 5 Nm torque.

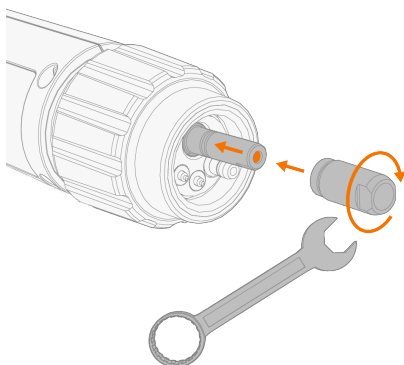

4.5.3 REPLACING WIRE LINER FOR MULTI-NECK

In addition to the wire liner, Flexlite GXe multi-neck welding torches require a separate neck wire liner to be replaced. For more information on wire liner replacement in general, refer to "Replacing steel wire liner" on page 19 and "Replacing DL Chili wire liner" on page 15.

1. Loosen the neck tightening collar and remove the neck.

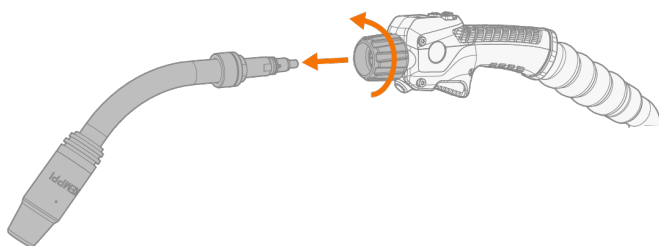

2. Remove the old neck wire liner.

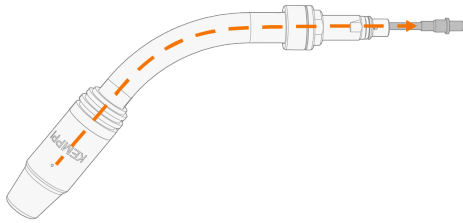

3. Insert the new neck wire liner into the neck and ensure that it goes all the way through and the liner's end (*) sits firmly in its housing.

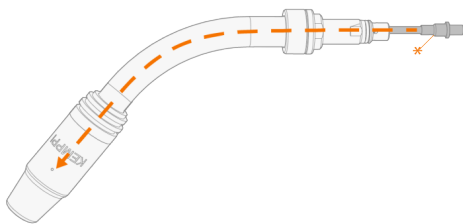

4. Attach the assembled neck to the torch body. Secure with the neck tightening collar.

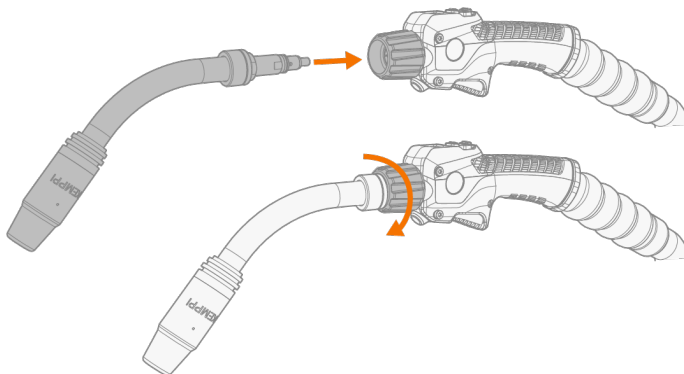

 *Hand-tighten only. Over-tightening and/or using a tool can damage the torch components.*

4.6 INSTALLING ADDITIONAL GUN HANDLE AND HEAT PROTECTOR (OPTIONAL)

The additional gun handle and heat protector are available for all Flexlite GXe MIG welding torches.

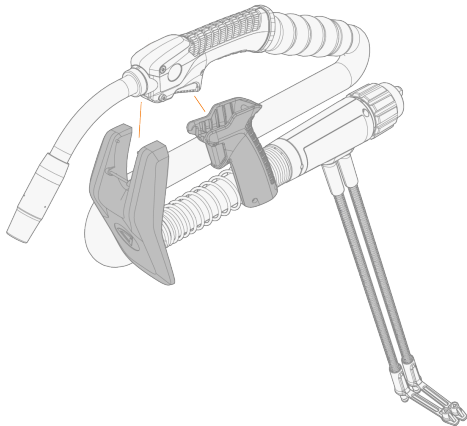

Gun handle

1. Keeping the bottom of the grip handle pointing forward, fit the inside grooves of the grip handle over the screws on the torch.

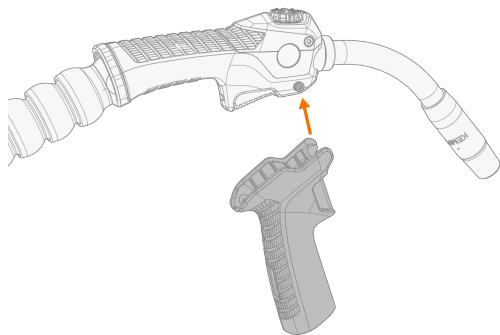

2. Pull the handle backward to lock it in position.

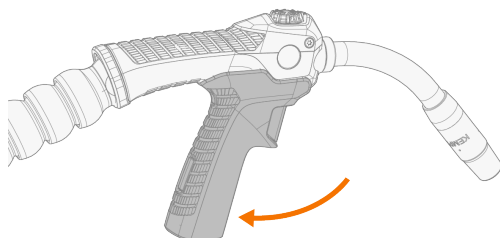

To remove the grip handle, press the unlock button in the grip handle rear:

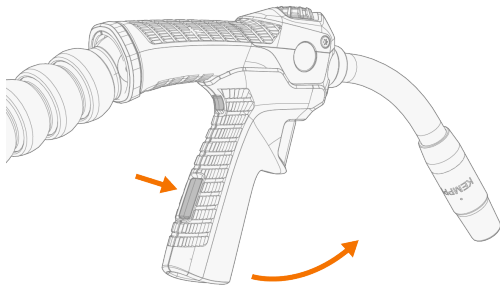

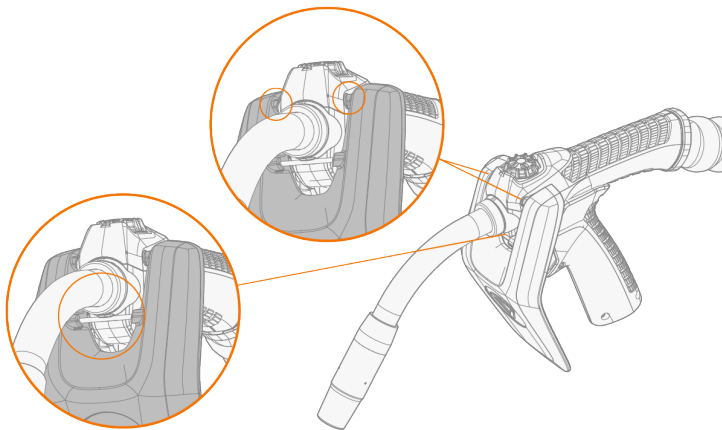

**Heat protector**

1. Place the heat protector's top fixing heads into the screw ends on both sides of the welding torch body.
2. Push the bottom of the heat protector towards the handle so that the protector clicks in place.



5. OPERATION

Before using the equipment, ensure that all the necessary installation actions have been completed according to your equipment setup and instructions.

-  *Welding is forbidden in places where there is an immediate fire or explosion hazard!*
-  *Welding fumes may cause injury. Take care to ensure sufficient ventilation during welding and wear respiratory protection!*
-  *Always check before use that interconnecting cable, shielding gas hose, earth return lead/clamp and mains cable are in serviceable condition. Ensure that the connectors are correctly fastened. Loose connectors can impair welding performance and damage connectors.*
-  *The exact function of the torch and trigger may vary depending on your welding machine settings (e.g. 2T, 4T or Minilog).*

To start welding, press the trigger switch.

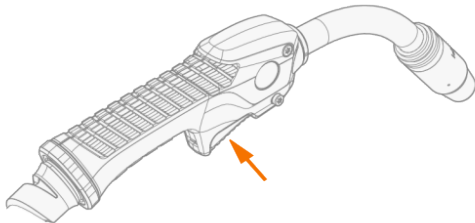

"Using torch remote GRe50 (series 3 and 5)" on the next page

"Using torch remote GRe80 (series 8)" on page 28

With the gas-cooled Flexlite GXe welding torches (G-models), the neck direction can be adjusted (360°) by turning it.

For more information on component selection and availability, refer to "Component selection" on page 71.

5.1 USING TORCH REMOTE GRE50 (SERIES 3 AND 5)

Adjust the wire feed speed or change the memory channel by turning the roller switch on the torch handle.

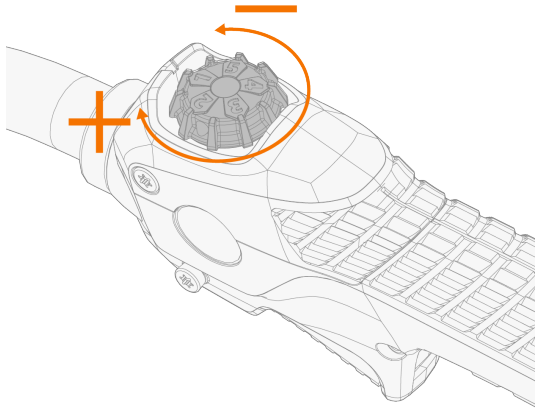

By default, the roller switch adjustment is stepwise according to the number values on the roller. The adjustment feel of the roller can be changed to stepless by turning the screw under the roller switch. This requires removing the roller switch temporarily.

5.2 USING TORCH REMOTE GRE80 (SERIES 8)

i The series 8 Flexlite GXe welding torches can be used with X5 FastMig and Master M (350 models) welding equipment only.

With the GRe80 welding torch remote control, you can select memory channels and adjust wire feed speed, welding current, welding voltage or voltage fine tuning depending on the welding process used.

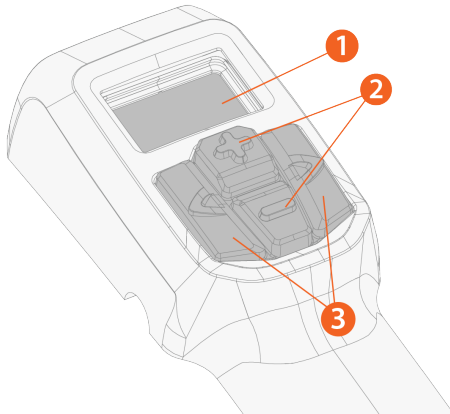

1. Custom LCD display
 - >> Displays the adjusted parameter and notifies if there is an error ("Err") in the welding system.
2. Plus/minus (+/-) buttons
 - >> Changes the parameter value.
3. Left/right arrow buttons
 - >> Changes between adjustable parameters/views.

Remote control display items

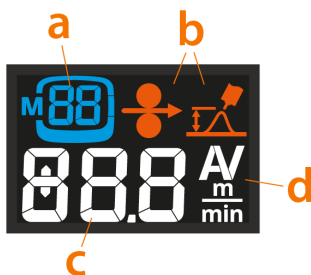

- a. Memory channel symbol and selected memory channel
- b. Wire feed speed and fine tuning symbols
- c. Adjusted parameter value (or error indicator)
- d. Adjusted parameter unit

When the parameter is adjusted with the remote and the parameter value doesn't reflect the one saved on the selected memory channel anymore, this is indicated on the display by showing only the memory channel number without the channel box around it:

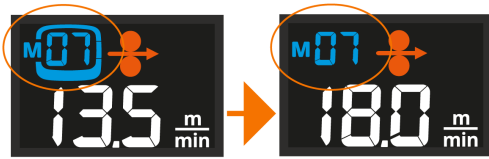

Remote control views and operation

- **Memory channel view:** The memory channel is changed by pressing the +/- buttons. Long press of a +/- button scrolls the parameter values faster. Long press of the left arrow button saves the adjusted parameters on the currently selected channel.
- **Welding power view:** Depending on the used welding process, wire feed speed or current is adjusted by pressing the +/- buttons. Long press of a +/- button scrolls the parameter values faster.
- **Fine tuning view:** Depending on the welding process used, voltage or welding process specific parameter is fine-tuned by pressing the +/- buttons. Long press of the +/- button scrolls the parameter values faster. Long press of the right arrow button switches between different parameter sets, as applicable.

6. MAINTENANCE

When planning routine maintenance, consider the operating frequency of the welding equipment and the working environment.

Correct operation of the welding equipment and regular maintenance helps you avoid unnecessary downtime and equipment failure. Mainly due to the high temperatures, MIG welding torches require regular checks and maintenance. Periodically, check the cables set for damage and ensure connections are tightened correctly.

Daily maintenance

 *Disconnect the power source from the mains power supply before handling electrical cables.*

- Check regularly that all the components are tightly fastened.
- Check that the current transfer surface on the Kemppi torch adapter is clean and unscratched, and the connector pins are straight and undamaged.
- Check the protective hose on the cable for damage.
- Check the O-rings in the welding torch gas connector for wear and damage.

 *The gas-cooled GXe torch does not have O-rings.*

- Clean dust from the liner with pressurized air every time you change the wire spool, or every day during heavy use.
- Check and remove any spatter build-up from the nozzle.
- When not using the torch, keep it in the welding torch holder on the wire feeder.

For repairs, contact your Kemppi dealer.

Periodic maintenance

 *Only qualified service personnel are allowed to carry out periodic maintenance.*

Check the electrical connectors of the unit at least every six months. Clean oxidized parts and tighten loose connectors.

 *Use the correct tension torque when fastening loose parts.*

 *Do not use pressure washing devices.*

Service workshops

Kemppi Service Workshops complete the welding system maintenance according to the Kemppi service agreement.

The main aspects in the service workshop maintenance procedure are:

- Cleanup of the machine
- Maintenance of the welding tools
- Checkup of the connectors and switches
- Checkup of all electric connections
- Checkup of the power source mains cable and plug
- Repair of defective parts and replacement of defective components

- Maintenance test
- Test and calibration of operation and performance values when needed.

Find your closest service workshop at Kempfi website.

6.1 TROUBLESHOOTING

 *The problems and the possible causes listed are not definitive, but suggest some typical situations that may turn up during normal use of the welding system. For further information and assistance, contact your nearest Kemppi service workshop.*

General:

The welding system does not power up

- Check that the mains cable is plugged in properly.
- Check that the mains switch of the power source is at the ON position.
- Check that the mains power distribution is on.
- Check the mains fuse and/or the circuit breaker.
- Check that the earth return cable is connected.

The welding system stops working

- The torch may have overheated. Wait for it to cool down.
- Check that none of the cables is loose.
- The wire feeder may have overheated. Wait for it to cool down and see that the welding current cable is properly attached.
- The power source may have overheated. Wait for it to cool down and see that the cooling fans work properly and the air flow is unobstructed.

Wire feeder:

The filler wire on the spool unravels

- Check that the spool locking cover is closed.

The wire feeder does not feed the filler wire

- Check that the filler wire has not run out.
- Check that the filler wire is properly routed through the feed rolls to the wire liner.
- Check that the pressure handle is properly closed.
- Check that the feed roll pressure is adjusted correctly for the filler wire.
- Blow compressed air through the wire liner to check that it is not blocked.

Welding torch:

The wire burns into the contact tip

- Make sure the size and type of the current tip and liner are suitable for the filler wire.
- Make sure the wire liner is clean.
- Make sure the wire liner does not make any steep loops.
- Check the motor current level. If the current is too high, there may be problems in the wire liner.
- Check the tightness of the feeding rolls. Too tight feeding rolls may affect soft filler wires, such as aluminum and flux-cored wires.

The torch overheats

- Make sure the torch neck is correctly connected to the handle.
- Make sure that the contact tip adapter is properly hand-tightened and the contact tip properly attached to it.
- Make sure that the welding parameters are within the range of the welding torch and the neck. The torch and the neck have separate limits for the maximum current; the lower one of these is the maximum current that can be used.

The torch neck overheats

- Make sure you are using original Kemppi consumable and spare parts. Incorrect spare part materials may cause the overheating of the neck.

The welding torch connector overheats

- Make sure the connector is properly connected to the wire feeder.
- Make sure the current transfer surface and the connector pins of the torch connector are clean and undamaged.

The torch vibrates too much during welding

- Check the tightness of the contact tip adapter and contact tip.
- Check the motor current.
- Check the wire liner (e.g. for dirt and to ensure that the wire liner has been cut properly).
- Check the filler wire. It must be straight and start coiling when it comes out from the contact tip. If not, check the tightness of the feeding rolls.
- Check the filler wire batch for any quality issues with the wire.

Weld quality:

Dirty and/or poor weld quality

- Check that the shielding gas has not run out.
- Check that the shielding gas flow is unobstructed.
- Check that the gas type is correct for the application.
- Check the polarity of the torch/electrode.
- Check that the welding procedure is correct for the application.

Varying welding performance

- Check that the wire feed mechanism is adjusted properly.
- Blow compressed air through the wire liner to check that it is not blocked.
- Check that the wire liner is correct for the selected wire size and type.
- Check the welding torch contact tip's size, type and wear.
- Check that the welding torch is not overheating.
- Check that the earth return clamp is properly attached to a clean surface of the workpiece.

High spatter volume

- Check the welding parameter values and welding procedure.
- Check the gas type and flow.
- Check the polarity of the torch/electrode.
- Check that the filler wire is correct for the current application.

6.2 DISPOSAL



Do not dispose of any electrical equipment with normal waste!

In observance of WEEE Directive 2012/19/EU on waste of electrical and electronic equipment and European Directive 2011/65/EU on the restriction of the use of certain hazardous substances in electrical and electronic equipment, and their implementation in accordance with national law, electrical equipment that has reached the end of its life must be collected separately and taken to an appropriate environmentally responsible recycling facility. The owner of the equipment is obliged to deliver a decommissioned unit to a regional collection center, as per the instructions of local authorities or a Kempfi representative. By applying these European Directives you improve the environment and human health.

For more information:



7. TECHNICAL DATA

"Technical data: Flexlite GXe 200A (gas-cooled)" on the next page

"Technical data: Flexlite GXe 300A (gas-cooled)" on page 42

"Technical data: Flexlite GXe 400A (gas-cooled)" on page 48

"Technical data: Flexlite GXe 300A (water-cooled)" on page 56

"Technical data: Flexlite GXe 400A (water-cooled)" on page 61

"Technical data: Flexlite GXe 500A (water-cooled)" on page 67

7.1 TECHNICAL DATA: FLEXLITE GXE 200A (GAS-COOLED)

Flexlite GXe 205G (3.5 m):

GXe 205G	
Feature	Value
Welding connection type	Euro
Type of cooling	Air
Contact tip	M10x1
Method of guidance	Manual
Load capacity 35% / Ar + 18% CO ₂	200 A
Load capacity test, filler wire material	Fe
Load capacity test, filler wire diameter	1 mm
Load capacity test, stick out length	15 mm
Load capacity test, gas flow	13 l/min
Filler wire diameter, Fe	0.8...1.2 mm
Filler wire diameter, Ss	0.8...1.2 mm
Filler wire diameter, Al	0.8...1.2 mm
Filler wire diameter, Fe-MC/FC	0.9...1.2 mm
Filler wire diameter, Ss-MC/FC	0.9...1.2 mm
Gun handle	Yes
Neck type	Rotating
Neck dimensions: length	123 mm
Neck dimensions: height	77 mm
Neck dimensions: angle	45 °
Remote control	Optional
Operating temperature range	-20...40 °C
Storage temperature range	-40...60 °C
Standards	IEC 60974-7

Flexlite GXe 205G (5 m):

GXe 205G	
Feature	Value
Welding connection type	Euro
Type of cooling	Air
Contact tip	M10x1
Method of guidance	Manual
Load capacity 35% / Ar + 18% CO ₂	200 A
Load capacity test, filler wire material	Fe

Load capacity test, filler wire diameter	1 mm
Load capacity test, stick out length	15 mm
Load capacity test, gas flow	13 l/min
Filler wire diameter, Fe	0.8...1.2 mm
Filler wire diameter, Ss	0.8...1.2 mm
Filler wire diameter, Al	0.8...1.2 mm
Filler wire diameter, Fe-MC/FC	0.9...1.2 mm
Filler wire diameter, Ss-MC/FC	0.9...1.2 mm
Gun handle	Yes
Neck type	Rotating
Neck dimensions: length	123 mm
Neck dimensions: height	77 mm
Neck dimensions: angle	45 °
Remote control	Optional
Operating temperature range	-20...40 °C
Storage temperature range	-40...60 °C
Standards	IEC 60974-7

Flexlite GXe 223G (3 m):

GXe 223G 3M	
Feature	Value
Welding connection type	Euro
Type of cooling	Air
Contact tip	M10x1
Method of guidance	Manual
Load capacity 35% / Ar + 18% CO ₂	220 A
Load capacity 60% / Ar + 18% CO ₂	170 A
Load capacity test, filler wire material	Fe
Load capacity test, filler wire diameter	1 mm
Load capacity test, stick out length	15 mm
Load capacity test, gas flow	13 l/min
Filler wire diameter	0.8...1.2 mm
Filler wire diameter, Fe	0.8...1.2 mm
Filler wire diameter, Ss	0.8...1.2 mm
Filler wire diameter, Al	0.8...1.2 mm
Filler wire diameter, Fe-MC/FC	0.9...1.2 mm
Filler wire diameter, Ss-MC/FC	0.9...1.2 mm

Gun handle	Yes
Neck type	Rotating
Neck dimensions: length	123 mm
Neck dimensions: height	77 mm
Neck dimensions: angle	45 °
Cable type	Coaxial
Remote control	No
LED light	No
Operating temperature range	-20...40 °C
Storage temperature range	-40...60 °C
Standards	IEC 60974-7

Flexlite GXe 223G (3.5 m):

GXe 223G	
Feature	Value
Welding connection type	Euro
Type of cooling	Air
Contact tip	M10x1
Method of guidance	Manual
Load capacity 35% / Ar + 18% CO ₂	220 A
Load capacity 60% / Ar + 18% CO ₂	170 A
Load capacity test, filler wire material	Fe
Load capacity test, filler wire diameter	1 mm
Load capacity test, stick out length	15 mm
Load capacity test, gas flow	13 l/min
Filler wire diameter	0.8...1.2 mm
Filler wire diameter, Fe	0.8...1.2 mm
Filler wire diameter, Ss	0.8...1.2 mm
Filler wire diameter, Al	0.8...1.2 mm
Filler wire diameter, Fe-MC/FC	0.9...1.2 mm
Filler wire diameter, Ss-MC/FC	0.9...1.2 mm
Gun handle	Yes
Neck type	Rotating
Neck dimensions: length	123 mm
Neck dimensions: height	77 mm
Neck dimensions: angle	45 °
Remote control	Optional

Operating temperature range	-20...40 °C
Storage temperature range	-40...60 °C
Standards	IEC 60974-7

Flexlite GXe 223G (5 m):

GXe 223G	
Feature	Value
Welding connection type	Euro
Type of cooling	Air
Contact tip	M10x1
Method of guidance	Manual
Load capacity 35% / Ar + 18% CO ₂	220 A
Load capacity 60% / Ar + 18% CO ₂	170 A
Load capacity test, filler wire material	Fe
Load capacity test, filler wire diameter	1 mm
Load capacity test, stick out length	15 mm
Load capacity test, gas flow	13 l/min
Filler wire diameter	0.8...1.2 mm
Filler wire diameter, Fe	0.8...1.2 mm
Filler wire diameter, Ss	0.8...1.2 mm
Filler wire diameter, Al	0.8...1.2 mm
Filler wire diameter, Fe-MC/FC	0.9...1.2 mm
Filler wire diameter, Ss-MC/FC	0.9...1.2 mm
Gun handle	Yes
Neck type	Rotating
Neck dimensions: length	123 mm
Neck dimensions: height	77 mm
Neck dimensions: angle	45 °
Remote control	Optional
Operating temperature range	-20...40 °C
Storage temperature range	-40...60 °C
Standards	IEC 60974-7

Flexlite GXe 253G (3.5 m):

GXe 253G	
Feature	Value
Welding connection type	Euro

Type of cooling	Air
Contact tip	M6
Method of guidance	Manual
Load capacity 35% / Ar + 18% CO ₂	250 A
Load capacity 60% / Ar + 18% CO ₂	200 A
Load capacity test, filler wire material	Fe
Load capacity test, filler wire diameter	1 mm
Load capacity test, stick out length	15 mm
Load capacity test, gas flow	13 l/min
Filler wire diameter	0.6...1.2 mm
Filler wire diameter, Fe	0.6...1.2 mm
Filler wire diameter, Ss	0.8...1.2 mm
Filler wire diameter, Al	0.8...1.2 mm
Filler wire diameter, Fe-MC/FC	0.9...1.2 mm
Filler wire diameter, Ss-MC/FC	0.9...1.2 mm
Gun handle	Yes
Neck type	Rotating
Neck dimensions: length	107 mm
Neck dimensions: height	65 mm
Neck dimensions: angle	40 °
Remote control	Optional
Operating temperature range	-20...40 °C
Storage temperature range	-40...60 °C
Standards	IEC 60974-7

Flexlite GXe 253G (5 m):

GXe 253G	
Feature	Value
Welding connection type	Euro
Type of cooling	Air
Contact tip	M6
Method of guidance	Manual
Load capacity 35% / Ar + 18% CO ₂	250 A
Load capacity 60% / Ar + 18% CO ₂	200 A
Load capacity test, filler wire material	Fe
Load capacity test, filler wire diameter	1 mm
Load capacity test, stick out length	15 mm

Load capacity test, gas flow	13 l/min
Filler wire diameter	0.6...1.2 mm
Filler wire diameter, Fe	0.6...1.2 mm
Filler wire diameter, Ss	0.8...1.2 mm
Filler wire diameter, Al	0.8...1.2 mm
Filler wire diameter, Fe-MC/FC	0.9...1.2 mm
Filler wire diameter, Ss-MC/FC	0.9...1.2 mm
Gun handle	Yes
Neck type	Rotating
Neck dimensions: length	107 mm
Neck dimensions: height	65 mm
Neck dimensions: angle	40 °
Remote control	Optional
Operating temperature range	-20...40 °C
Storage temperature range	-40...60 °C
Standards	IEC 60974-7

Neck dimensions, G-models:

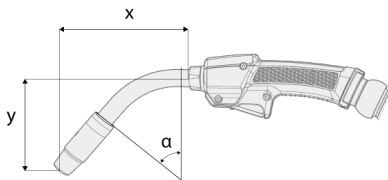

7.2 TECHNICAL DATA: FLEXLITE GXE 300A (GAS-COOLED)

Flexlite GXe 305G (3.5 m):

GXe 305G	
Feature	Value
Welding connection type	Euro
Type of cooling	Air
Contact tip	M10x1
Method of guidance	Manual
Load capacity 35% / Ar + 18% CO ₂	300 A
Load capacity test, filler wire material	Fe
Load capacity test, filler wire diameter	1.2 mm
Load capacity test, stick out length	18 mm
Load capacity test, gas flow	15 l/min
Filler wire diameter, Fe	0.8...1.2 mm
Filler wire diameter, Ss	0.8...1.2 mm
Filler wire diameter, Al	0.8...1.2 mm
Filler wire diameter, Fe-MC/FC	0.9...1.2 mm
Filler wire diameter, Ss-MC/FC	0.9...1.2 mm
Gun handle	Yes
Neck type	Rotating
Neck dimensions: length	135 mm
Neck dimensions: height	96 mm
Neck dimensions: angle	50 °
Remote control	Optional
Operating temperature range	-20...40 °C
Storage temperature range	-40...60 °C
Standards	IEC 60974-7

Flexlite GXe 305G (5 m):

GXe 305G	
Feature	Value
Welding connection type	Euro
Type of cooling	Air
Contact tip	M10x1
Method of guidance	Manual
Load capacity 35% / Ar + 18% CO ₂	300 A
Load capacity test, filler wire material	Fe

Load capacity test, filler wire diameter	1.2 mm
Load capacity test, stick out length	18 mm
Load capacity test, gas flow	15 l/min
Filler wire diameter, Fe	0.8...1.2 mm
Filler wire diameter, Ss	0.8...1.2 mm
Filler wire diameter, Al	0.8...1.2 mm
Filler wire diameter, Fe-MC/FC	0.9...1.2 mm
Filler wire diameter, Ss-MC/FC	0.9...1.2 mm
Gun handle	Yes
Neck type	Rotating
Neck dimensions: length	135 mm
Neck dimensions: height	96 mm
Neck dimensions: angle	50 °
Remote control	Optional
Operating temperature range	-20...40 °C
Storage temperature range	-40...60 °C
Standards	IEC 60974-7

Flexlite GXe 305G (6 m):

GXe 305G 6m	
Feature	Value
Welding connection type	Euro
Type of cooling	Air
Contact tip	M10x1
Method of guidance	Manual
Load capacity 35% / Ar + 18% CO2	300 A
Load capacity test, filler wire material	Fe
Load capacity test, filler wire diameter	1.2 mm
Load capacity test, stick out length	18 mm
Load capacity test, gas flow	15 l/min
Filler wire diameter	1...1.2 mm
Filler wire diameter, Ss	1...1.2 mm
Filler wire diameter, Al	1.2...1.2 mm
Gun handle	Yes
Neck type	Rotating
Neck dimensions: length	135 mm
Neck dimensions: height	96 mm
Neck dimensions: angle	50 °

Remote control	Optional
Operating temperature range	-20...40 °C
Storage temperature range	-40...60 °C
Standards	IEC 60974-7

Flexlite GXe 308GA (3.5 m):

GXe 308GA (+GRe80)	
Feature	Value
Welding connection type	Euro
Type of cooling	Air
Contact tip	M10x1
Method of guidance	Manual
Load capacity 35% / Ar + 18% CO ₂	300 A
Load capacity test, filler wire material	Fe
Load capacity test, filler wire diameter	1.2 mm
Load capacity test, stick out length	18 mm
Load capacity test, gas flow	15 l/min
Filler wire diameter, Fe	0.8...1.2 mm
Filler wire diameter, Ss	0.8...1.2 mm
Filler wire diameter, Al	0.8...1.2 mm
Filler wire diameter, Fe-MC/FC	0.9...1.2 mm
Filler wire diameter, Ss-MC/FC	0.9...1.2 mm
Gun handle	Yes
Neck type	Rotating
Neck dimensions: length	135 mm
Neck dimensions: height	96 mm
Neck dimensions: angle	50 °
Remote control	Yes
Operating temperature range	-20...40 °C
Storage temperature range	-40...60 °C
Standards	IEC 60974-7

Flexlite GXe 308GA (5 m):

GXe 308GA (+GRe80)	
Feature	Value
Welding connection type	Euro
Type of cooling	Air
Contact tip	M10x1

Method of guidance	Manual
Load capacity 35% / Ar + 18% CO ₂	300 A
Load capacity test, filler wire material	Fe
Load capacity test, filler wire diameter	1.2 mm
Load capacity test, stick out length	18 mm
Load capacity test, gas flow	15 l/min
Filler wire diameter, Fe	0.8...1.2 mm
Filler wire diameter, Ss	0.8...1.2 mm
Filler wire diameter, Al	0.8...1.2 mm
Filler wire diameter, Fe-MC/FC	0.9...1.2 mm
Filler wire diameter, Ss-MC/FC	0.9...1.2 mm
Gun handle	Yes
Neck type	Rotating
Neck dimensions: length	135 mm
Neck dimensions: height	96 mm
Neck dimensions: angle	50 °
Remote control	Yes
Operating temperature range	-20...40 °C
Storage temperature range	-40...60 °C
Standards	IEC 60974-7

Flexlite GXe 323G (3.5 m):

GXe 323G	
Feature	Value
Welding connection type	Euro
Type of cooling	Air
Contact tip	M10x1
Method of guidance	Manual
Load capacity 35% / Ar + 18% CO ₂	320 A
Load capacity 60% / Ar + 18% CO ₂	270 A
Load capacity test, filler wire material	Fe
Load capacity test, filler wire diameter	1.2 mm
Load capacity test, stick out length	18 mm
Load capacity test, gas flow	15 l/min
Filler wire diameter	0.8...1.6 mm
Filler wire diameter, Fe	0.8...1.6 mm
Filler wire diameter, Ss	0.8...1.6 mm

Filler wire diameter, Al	0.8...1.6 mm
Filler wire diameter, Fe-MC/FC	0.9...1.6 mm
Filler wire diameter, Ss-MC/FC	0.9...1.6 mm
Gun handle	Yes
Neck type	Rotating
Neck dimensions: length	135 mm
Neck dimensions: height	96 mm
Neck dimensions: angle	50 °
Remote control	Optional
Operating temperature range	-20...40 °C
Storage temperature range	-40...60 °C
Standards	IEC 60974-7

Flexlite GXe 323G (5 m):

GXe 323G	
Feature	Value
Welding connection type	Euro
Type of cooling	Air
Contact tip	M10x1
Method of guidance	Manual
Load capacity 35% / Ar + 18% CO ₂	320 A
Load capacity 60% / Ar + 18% CO ₂	270 A
Load capacity test, filler wire material	Fe
Load capacity test, filler wire diameter	1.2 mm
Load capacity test, stick out length	18 mm
Load capacity test, gas flow	15 l/min
Filler wire diameter	0.8...1.6 mm
Filler wire diameter, Fe	0.8...1.6 mm
Filler wire diameter, Ss	0.8...1.6 mm
Filler wire diameter, Al	0.8...1.6 mm
Filler wire diameter, Fe-MC/FC	0.9...1.6 mm
Filler wire diameter, Ss-MC/FC	0.9...1.6 mm
Gun handle	Yes
Neck type	Rotating
Neck dimensions: length	135 mm
Neck dimensions: height	96 mm
Neck dimensions: angle	50 °

Remote control	Optional
Operating temperature range	-20...40 °C
Storage temperature range	-40...60 °C
Standards	IEC 60974-7

Neck dimensions, G-models:

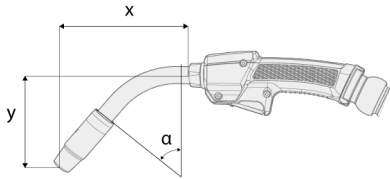

7.3 TECHNICAL DATA: FLEXLITE GXE 400A (GAS-COOLED)

Flexlite GXe 403GMN (3.5 m):

GXe 403G MN	
Feature	Value
Welding connection type	Euro
Type of cooling	Air
Contact tip	M10x1
Method of guidance	Manual
Load capacity 35% / Ar + 18% CO ₂	400 A
Load capacity 60% / Ar + 18% CO ₂	360 A
Load capacity test, filler wire material	Fe
Load capacity test, filler wire diameter	1.6 mm
Load capacity test, stick out length	22 mm
Load capacity test, gas flow	20 l/min
Filler wire diameter	0.8...1.6 mm
Filler wire diameter, Fe	0.8...1.6 mm
Filler wire diameter, Ss	0.8...1.6 mm
Filler wire diameter, Al	0.8...1.6 mm
Filler wire diameter, Fe-MC/FC	0.9...1.6 mm
Filler wire diameter, Ss-MC/FC	0.9...1.6 mm
Gun handle	Yes
Neck type	Changeable
Neck dimensions: length	152 mm
Neck dimensions: height	105 mm
Neck dimensions: angle	50 °
Remote control	Optional
Operating temperature range	-20...40 °C
Storage temperature range	-40...60 °C
Standards	IEC 60974-7

Flexlite GXe 403GMN (5 m):

GXe 403G MN	
Feature	Value
Welding connection type	Euro
Type of cooling	Air
Contact tip	M10x1
Method of guidance	Manual

Load capacity 35% / Ar + 18% CO ₂	400 A
Load capacity 60% / Ar + 18% CO ₂	360 A
Load capacity test, filler wire material	Fe
Load capacity test, filler wire diameter	1.6 mm
Load capacity test, stick out length	22 mm
Load capacity test, gas flow	20 l/min
Filler wire diameter	0.8...1.6 mm
Filler wire diameter, Fe	0.8...1.6 mm
Filler wire diameter, Ss	0.8...1.6 mm
Filler wire diameter, Al	0.8...1.6 mm
Filler wire diameter, Fe-MC/FC	0.9...1.6 mm
Filler wire diameter, Ss-MC/FC	0.9...1.6 mm
Gun handle	Yes
Neck type	Changeable
Neck dimensions: length	152 mm
Neck dimensions: height	105 mm
Neck dimensions: angle	50 °
Remote control	Optional
Operating temperature range	-20...40 °C
Storage temperature range	-40...60 °C
Standards	IEC 60974-7

Flexlite GXe 405G (3.5 m):

GXe 405G	
Feature	Value
Welding connection type	Euro
Type of cooling	Air
Contact tip	M10x1
Method of guidance	Manual
Load capacity 35% / Ar + 18% CO ₂	400 A
Load capacity test, filler wire material	Fe
Load capacity test, filler wire diameter	1.6 mm
Load capacity test, stick out length	22 mm
Load capacity test, gas flow	20 l/min
Filler wire diameter, Fe	0.8...1.6 mm
Filler wire diameter, Ss	0.8...1.6 mm
Filler wire diameter, Al	0.8...1.6 mm

Filler wire diameter, Fe-MC/FC	0.9...1.6 mm
Filler wire diameter, Ss-MC/FC	0.9...1.6 mm
Gun handle	Yes
Neck type	Rotating
Neck dimensions: length	149 mm
Neck dimensions: height	96 mm
Neck dimensions: angle	50 °
Remote control	Optional
Operating temperature range	-20...40 °C
Storage temperature range	-40...60 °C
Standards	IEC 60974-7

Flexlite GXe 405G (5 m):

GXe 405G	
Feature	Value
Welding connection type	Euro
Type of cooling	Air
Contact tip	M10x1
Method of guidance	Manual
Load capacity 35% / Ar + 18% CO ₂	400 A
Load capacity test, filler wire material	Fe
Load capacity test, filler wire diameter	1.6 mm
Load capacity test, stick out length	22 mm
Load capacity test, gas flow	20 l/min
Filler wire diameter, Fe	0.8...1.6 mm
Filler wire diameter, Ss	0.8...1.6 mm
Filler wire diameter, Al	0.8...1.6 mm
Filler wire diameter, Fe-MC/FC	0.9...1.6 mm
Filler wire diameter, Ss-MC/FC	0.9...1.6 mm
Gun handle	Yes
Neck type	Rotating
Neck dimensions: length	149 mm
Neck dimensions: height	96 mm
Neck dimensions: angle	50 °
Remote control	Optional
Operating temperature range	-20...40 °C
Storage temperature range	-40...60 °C
Standards	IEC 60974-7

Flexlite GXe 408GA (3.5 m):

GXe 408GA (+GRe80)	
Feature	Value
Welding connection type	Euro
Type of cooling	Air
Contact tip	M10x1
Method of guidance	Manual
Load capacity 35% / Ar + 18% CO ₂	400 A
Load capacity test, filler wire material	Fe
Load capacity test, filler wire diameter	1.6 mm
Load capacity test, stick out length	22 mm
Load capacity test, gas flow	20 l/min
Filler wire diameter, Fe	0.8...1.6 mm
Filler wire diameter, Ss	0.8...1.6 mm
Filler wire diameter, Al	0.8...1.6 mm
Filler wire diameter, Fe-MC/FC	0.9...1.6 mm
Filler wire diameter, Ss-MC/FC	0.9...1.6 mm
Gun handle	Yes
Neck type	Rotating
Neck dimensions: length	149 mm
Neck dimensions: height	102 mm
Neck dimensions: angle	50 °
Remote control	Yes
Operating temperature range	-20...40 °C
Storage temperature range	-40...60 °C
Standards	IEC 60974-7

Flexlite GXe 408GA (5 m):

GXe 408GA (+GRe80)	
Feature	Value
Welding connection type	Euro
Type of cooling	Air
Contact tip	M10x1
Method of guidance	Manual
Load capacity 35% / Ar + 18% CO ₂	400 A
Load capacity test, filler wire material	Fe
Load capacity test, filler wire diameter	1.6 mm
Load capacity test, stick out length	22 mm

Load capacity test, gas flow	20 l/min
Filler wire diameter, Fe	0.8...1.6 mm
Filler wire diameter, Ss	0.8...1.6 mm
Filler wire diameter, Al	0.8...1.6 mm
Filler wire diameter, Fe-MC/FC	0.9...1.6 mm
Filler wire diameter, Ss-MC/FC	0.9...1.6 mm
Gun handle	Yes
Neck type	Rotating
Neck dimensions: length	149 mm
Neck dimensions: height	102 mm
Neck dimensions: angle	50 °
Remote control	Yes
Operating temperature range	-20...40 °C
Storage temperature range	-40...60 °C
Standards	IEC 60974-7

Flexlite GXe 408GAMN (3.5 m):

GXe 408GA MN	
Feature	Value
Welding connection type	Euro+Amphenol
Type of cooling	Air
Contact tip	M10x1
Method of guidance	Manual
Load capacity 35% / Ar + 18% CO ₂	400 A
Load capacity 60% / Ar + 18% CO ₂	340 A
Load capacity test, filler wire material	Fe
Load capacity test, filler wire diameter	1.6 mm
Load capacity test, stick out length	22 mm
Load capacity test, gas flow	20 l/min
Filler wire diameter	0.8...1.6 mm
Filler wire diameter, Fe	0.8...1.6 mm
Filler wire diameter, Ss	0.8...1.6 mm
Filler wire diameter, Al	0.8...1.6 mm
Filler wire diameter, Fe-MC/FC	0.9...1.6 mm
Filler wire diameter, Ss-MC/FC	0.9...1.6 mm
Gun handle	Yes
Neck type	Changeable
Neck dimensions: length	152 mm

Neck dimensions: height	105 mm
Neck dimensions: angle	50 °
Remote control	Yes
Operating temperature range	-20...40 °C
Storage temperature range	-40...60 °C
Standards	IEC 60974-7

Flexlite GXe 408GAMN (5 m):

GXe 408GA MN	
Feature	Value
Welding connection type	Euro+Amphenol
Type of cooling	Air
Contact tip	M10x1
Method of guidance	Manual
Load capacity 35% / Ar + 18% CO2	400 A
Load capacity 60% / Ar + 18% CO2	340 A
Load capacity test, filler wire material	Fe
Load capacity test, filler wire diameter	1.6 mm
Load capacity test, stick out length	22 mm
Load capacity test, gas flow	20 l/min
Filler wire diameter	0.8...1.6 mm
Filler wire diameter, Fe	0.8...1.6 mm
Filler wire diameter, Ss	0.8...1.6 mm
Filler wire diameter, Al	0.8...1.6 mm
Filler wire diameter, Fe-MC/FC	0.9...1.6 mm
Filler wire diameter, Ss-MC/FC	0.9...1.6 mm
Gun handle	Yes
Neck type	Changeable
Neck dimensions: length	152 mm
Neck dimensions: height	105 mm
Neck dimensions: angle	50 °
Remote control	Yes
Operating temperature range	-20...40 °C
Storage temperature range	-40...60 °C
Standards	IEC 60974-7

Flexlite GXe 423G (3.5 m):

GXe 423G	
Feature	Value
Welding connection type	Euro
Type of cooling	Air
Contact tip	M10x1
Method of guidance	Manual
Load capacity 35% / Ar + 18% CO ₂	400 A
Load capacity 60% / Ar + 18% CO ₂	340 A
Load capacity test, filler wire material	Fe
Load capacity test, filler wire diameter	1.6 mm
Load capacity test, stick out length	22 mm
Load capacity test, gas flow	20 l/min
Filler wire diameter	0.8...1.6 mm
Filler wire diameter, Fe	0.8...1.6 mm
Filler wire diameter, Ss	0.8...1.6 mm
Filler wire diameter, Al	0.8...1.6 mm
Filler wire diameter, Fe-MC/FC	0.9...1.6 mm
Filler wire diameter, Ss-MC/FC	0.9...1.6 mm
Gun handle	Yes
Neck type	Rotating
Neck dimensions: length	149 mm
Neck dimensions: height	102 mm
Neck dimensions: angle	50 °
Remote control	Optional
Operating temperature range	-20...40 °C
Storage temperature range	-40...60 °C
Standards	IEC 60974-7

Flexlite GXe 423G (5 m):

GXe 423G	
Feature	Value
Welding connection type	Euro
Type of cooling	Air
Contact tip	M10x1
Method of guidance	Manual
Load capacity 35% / Ar + 18% CO ₂	400 A

Load capacity 60% / Ar + 18% CO ₂	340 A
Load capacity test, filler wire material	Fe
Load capacity test, filler wire diameter	1.6 mm
Load capacity test, stick out length	22 mm
Load capacity test, gas flow	20 l/min
Filler wire diameter	0.8...1.6 mm
Filler wire diameter, Fe	0.8...1.6 mm
Filler wire diameter, Ss	0.8...1.6 mm
Filler wire diameter, Al	0.8...1.6 mm
Filler wire diameter, Fe-MC/FC	0.9...1.6 mm
Filler wire diameter, Ss-MC/FC	0.9...1.6 mm
Gun handle	Yes
Neck type	Rotating
Neck dimensions: length	149 mm
Neck dimensions: height	102 mm
Neck dimensions: angle	50 °
Remote control	Optional
Operating temperature range	-20...40 °C
Storage temperature range	-40...60 °C
Standards	IEC 60974-7

Neck dimensions, G-models:

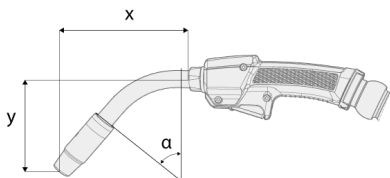

Neck dimensions, MN-models:

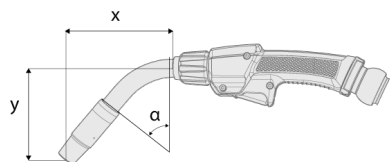

7.4 TECHNICAL DATA: FLEXLITE GXE 300A (WATER-COOLED)

Flexlite GXe 305W (3.5 m):

GXe 305W	
Feature	Value
Welding connection type	Euro
Type of cooling	Liquid
Contact tip	M10x1
Method of guidance	Manual
Load capacity 100% / Ar + 18% CO ₂	300 A
Load capacity test, filler wire material	Fe
Load capacity test, filler wire diameter	1.2 mm
Load capacity test, stick out length	18 mm
Load capacity test, gas flow	15 l/min
Filler wire diameter, Fe	0.8...1.6 mm
Filler wire diameter, Ss	0.8...1.6 mm
Filler wire diameter, Al	0.8...1.6 mm
Filler wire diameter, Fe-MC/FC	0.9...1.6 mm
Filler wire diameter, Ss-MC/FC	0.9...1.6 mm
Coolant flow rate	1 l/min
Minimum cooling power at 1 l/min	0.9 kW
Maximum coolant pressure	5 Bar
Gun handle	Yes
Neck type	Standard
Neck dimensions: length	126 mm
Neck dimensions: height	93 mm
Neck dimensions: angle	48 °
Remote control	Optional
Operating temperature range	-20...40 °C
Storage temperature range	-40...60 °C
Standards	IEC 60974-7

Flexlite GXe 305W (5 m):

GXe 305W	
Feature	Value
Welding connection type	Euro
Type of cooling	Liquid

Contact tip	M10x1
Method of guidance	Manual
Load capacity 100% / Ar + 18% CO ₂	300 A
Load capacity test, filler wire material	Fe
Load capacity test, filler wire diameter	1.2 mm
Load capacity test, stick out length	18 mm
Load capacity test, gas flow	15 l/min
Filler wire diameter, Fe	0.8...1.6 mm
Filler wire diameter, Ss	0.8...1.6 mm
Filler wire diameter, Al	0.8...1.6 mm
Filler wire diameter, Fe-MC/FC	0.9...1.6 mm
Filler wire diameter, Ss-MC/FC	0.9...1.6 mm
Coolant flow rate	1 l/min
Minimum cooling power at 1 l/min	0.9 kW
Maximum coolant pressure	5 Bar
Gun handle	Yes
Neck type	Standard
Neck dimensions: length	126 mm
Neck dimensions: height	93 mm
Neck dimensions: angle	48 °
Remote control	Optional
Operating temperature range	-20...40 °C
Storage temperature range	-40...60 °C
Standards	IEC 60974-7

Flexlite GXe 305W (6 m):

GXe 305W 6m	
Feature	Value
Welding connection type	Euro
Type of cooling	Liquid
Contact tip	M10x1
Method of guidance	Manual
Load capacity 100% / Ar + 18% CO ₂	250 A
Load capacity test, filler wire material	Fe
Load capacity test, filler wire diameter	1.2 mm
Load capacity test, stick out length	18 mm
Load capacity test, gas flow	15 l/min

Filler wire diameter	1...1.6 mm
Filler wire diameter, Ss	1...1.2 mm
Filler wire diameter, Al	1.2...1.6 mm
Coolant flow rate	1 l/min
Minimum cooling power at 1 l/min	0.9 kW
Maximum coolant pressure	5 Bar
Gun handle	Yes
Neck type	Standard
Neck dimensions: length	126 mm
Neck dimensions: height	93 mm
Neck dimensions: angle	48 °
Remote control	Optional
Operating temperature range	-20...40 °C
Storage temperature range	-40...60 °C
Standards	IEC 60974-7

Flexlite GXe 308WA (3.5 m):

GXe 308WA (+GRe80)	
Feature	Value
Welding connection type	Euro
Type of cooling	Liquid
Contact tip	M10x1
Method of guidance	Manual
Load capacity 100% / Ar + 18% CO2	300 A
Load capacity test, filler wire material	Fe
Load capacity test, filler wire diameter	1.2 mm
Load capacity test, stick out length	18 mm
Load capacity test, gas flow	15 l/min
Filler wire diameter, Fe	0.8...1.6 mm
Filler wire diameter, Ss	0.8...1.6 mm
Filler wire diameter, Al	0.8...1.6 mm
Filler wire diameter, Fe-MC/FC	0.9...1.6 mm
Filler wire diameter, Ss-MC/FC	0.9...1.6 mm
Coolant flow rate	1 l/min
Minimum cooling power at 1 l/min	0.9 kW
Maximum coolant pressure	5 Bar
Gun handle	Yes

Neck type	Standard
Neck dimensions: length	126 mm
Neck dimensions: height	93 mm
Neck dimensions: angle	48 °
Remote control	Yes
Operating temperature range	-20...40 °C
Storage temperature range	-40...60 °C
Standards	IEC 60974-7

Flexlite GXe 308WA (5 m):

GXe 308WA (+GRe80)	
Feature	Value
Welding connection type	Euro
Type of cooling	Liquid
Contact tip	M10x1
Method of guidance	Manual
Load capacity 100% / Ar + 18% CO ₂	300 A
Load capacity test, filler wire material	Fe
Load capacity test, filler wire diameter	1.2 mm
Load capacity test, stick out length	18 mm
Load capacity test, gas flow	15 l/min
Filler wire diameter, Fe	0.8...1.6 mm
Filler wire diameter, Ss	0.8...1.6 mm
Filler wire diameter, Al	0.8...1.6 mm
Filler wire diameter, Fe-MC/FC	0.9...1.6 mm
Filler wire diameter, Ss-MC/FC	0.9...1.6 mm
Coolant flow rate	1 l/min
Minimum cooling power at 1 l/min	0.9 kW
Maximum coolant pressure	5 Bar
Gun handle	Yes
Neck type	Standard
Neck dimensions: length	126 mm
Neck dimensions: height	93 mm
Neck dimensions: angle	48 °
Remote control	Yes
Operating temperature range	-20...40 °C
Storage temperature range	-40...60 °C
Standards	IEC 60974-7

Neck dimensions, W-models:

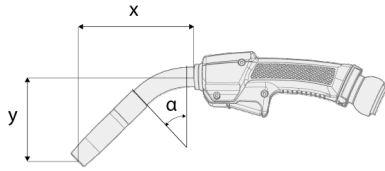

7.5 TECHNICAL DATA: FLEXLITE GXE 400A (WATER-COOLED)

Flexlite GXe 405W (3.5 m):

GXe 405W	
Feature	Value
Welding connection type	Euro
Type of cooling	Liquid
Contact tip	M10x1
Method of guidance	Manual
Load capacity 100% / Ar + 18% CO ₂	400 A
Load capacity test, filler wire material	Fe
Load capacity test, filler wire diameter	1.6 mm
Load capacity test, stick out length	22 mm
Load capacity test, gas flow	20 l/min
Filler wire diameter, Fe	0.8...1.6 mm
Filler wire diameter, Ss	0.8...1.6 mm
Filler wire diameter, Al	0.8...1.6 mm
Filler wire diameter, Fe-MC/FC	0.9...1.6 mm
Filler wire diameter, Ss-MC/FC	0.9...1.6 mm
Coolant flow rate	1 l/min
Minimum cooling power at 1 l/min	0.9 kW
Maximum coolant pressure	5 Bar
Gun handle	Yes
Neck type	Standard
Neck dimensions: length	144 mm
Neck dimensions: height	99 mm
Neck dimensions: angle	48 °
Remote control	Optional
Operating temperature range	-20...40 °C
Storage temperature range	-40...60 °C
Standards	IEC 60974-7

Flexlite GXe 405W (5 m):

GXe 405W	
Feature	Value
Welding connection type	Euro
Type of cooling	Liquid

Contact tip	M10x1
Method of guidance	Manual
Load capacity 100% / Ar + 18% CO ₂	400 A
Load capacity test, filler wire material	Fe
Load capacity test, filler wire diameter	1.6 mm
Load capacity test, stick out length	22 mm
Load capacity test, gas flow	20 l/min
Filler wire diameter, Fe	0.8...1.6 mm
Filler wire diameter, Ss	0.8...1.6 mm
Filler wire diameter, Al	0.8...1.6 mm
Filler wire diameter, Fe-MC/FC	0.9...1.6 mm
Filler wire diameter, Ss-MC/FC	0.9...1.6 mm
Coolant flow rate	1 l/min
Minimum cooling power at 1 l/min	0.9 kW
Maximum coolant pressure	5 Bar
Gun handle	Yes
Neck type	Standard
Neck dimensions: length	144 mm
Neck dimensions: height	99 mm
Neck dimensions: angle	48 °
Remote control	Optional
Operating temperature range	-20...40 °C
Storage temperature range	-40...60 °C
Standards	IEC 60974-7

Flexlite GXe 405W (6 m):

GXe 405W 6m	
Feature	Value
Welding connection type	Euro
Type of cooling	Liquid
Contact tip	M10x1
Method of guidance	Manual
Load capacity 100% / Ar + 18% CO ₂	300 A
Load capacity test, filler wire material	Fe
Load capacity test, filler wire diameter	1.6 mm
Load capacity test, stick out length	22 mm
Load capacity test, gas flow	20 l/min
Filler wire diameter	1...1.6 mm

Filler wire diameter, Ss	1...1.2 mm
Filler wire diameter, Al	1.2...1.6 mm
Coolant flow rate	1 l/min
Minimum cooling power at 1 l/min	0.9 kW
Maximum coolant pressure	5 Bar
Gun handle	Yes
Neck type	Standard
Neck dimensions: length	144 mm
Neck dimensions: height	99 mm
Neck dimensions: angle	48 °
Remote control	Optional
Operating temperature range	-20...40 °C
Storage temperature range	-40...60 °C
Standards	IEC 60974-7

Flexlite GXe 405W (8 m):

GXe 405W 8m	
Feature	Value
Welding connection type	Euro
Type of cooling	Liquid
Contact tip	M10x1
Method of guidance	Manual
Load capacity 100% / Ar + 18% CO2	300 A
Load capacity test, filler wire material	Fe
Load capacity test, filler wire diameter	1.6 mm
Load capacity test, stick out length	22 mm
Load capacity test, gas flow	20 l/min
Filler wire diameter	1...1.6 mm
Filler wire diameter, Ss	1...1.2 mm
Filler wire diameter, Al	1.2...1.6 mm
Coolant flow rate	1 l/min
Minimum cooling power at 1 l/min	0.9 kW
Maximum coolant pressure	5 Bar
Gun handle	Yes
Neck type	Standard
Neck dimensions: length	144 mm
Neck dimensions: height	99 mm

Neck dimensions: angle	48 °
Remote control	Optional
Operating temperature range	-20...40 °C
Storage temperature range	40...-60 °C
Standards	IEC 60974-7

Flexlite GXe 408WA (3.5 m):

GXe 408WA (+GRe80)	
Feature	Value
Welding connection type	Euro
Type of cooling	Liquid
Contact tip	M10x1
Method of guidance	Manual
Load capacity 100% / Ar + 18% CO ₂	400 A
Load capacity test, filler wire material	Fe
Load capacity test, filler wire diameter	1.6 mm
Load capacity test, stick out length	22 mm
Load capacity test, gas flow	20 l/min
Filler wire diameter, Fe	0.8...1.6 mm
Filler wire diameter, Ss	0.8...1.6 mm
Filler wire diameter, Al	0.8...1.6 mm
Filler wire diameter, Fe-MC/FC	0.9...1.6 mm
Filler wire diameter, Ss-MC/FC	0.9...1.6 mm
Coolant flow rate	1 l/min
Minimum cooling power at 1 l/min	0.9 kW
Maximum coolant pressure	5 Bar
Gun handle	Yes
Neck type	Standard
Neck dimensions: length	144 mm
Neck dimensions: height	99 mm
Neck dimensions: angle	48 °
Remote control	Yes
Operating temperature range	-20...40 °C
Storage temperature range	-40...60 °C
Standards	IEC 60974-7

Flexlite GXe 408WA (5 m):

GXe 408WA (+GRe80)	
Feature	Value
Welding connection type	Euro
Type of cooling	Liquid
Contact tip	M10x1
Method of guidance	Manual
Load capacity 100% / Ar + 18% CO ₂	400 A
Load capacity test, filler wire material	Fe
Load capacity test, filler wire diameter	1.6 mm
Load capacity test, stick out length	22 mm
Load capacity test, gas flow	20 l/min
Filler wire diameter, Fe	0.8...1.6 mm
Filler wire diameter, Ss	0.8...1.6 mm
Filler wire diameter, Al	0.8...1.6 mm
Filler wire diameter, Fe-MC/FC	0.9...1.6 mm
Filler wire diameter, Ss-MC/FC	0.9...1.6 mm
Coolant flow rate	1 l/min
Minimum cooling power at 1 l/min	0.9 kW
Maximum coolant pressure	5 Bar
Gun handle	Yes
Neck type	Standard
Neck dimensions: length	144 mm
Neck dimensions: height	99 mm
Neck dimensions: angle	48 °
Remote control	Yes
Operating temperature range	-20...40 °C
Storage temperature range	-40...60 °C
Standards	IEC 60974-7

Flexlite GXe 408WA (8 m):

GXe 408WA 8m	
Feature	Value
Welding connection type	Euro+Amphenol
Type of cooling	Liquid
Contact tip	M10x1
Method of guidance	Manual
Load capacity 100% / Ar + 18% CO ₂	300 A

Load capacity test, filler wire material	Fe
Load capacity test, filler wire diameter	1.6 mm
Load capacity test, stick out length	22 mm
Load capacity test, gas flow	20 l/min
Filler wire diameter	1...1.6 mm
Filler wire diameter, Ss	1...1.2 mm
Filler wire diameter, Al	1.2...1.6 mm
Coolant flow rate	1 l/min
Minimum cooling power at 1 l/min	0.9 kW
Maximum coolant pressure	5 Bar
Gun handle	Yes
Neck type	Standard
Neck dimensions: length	144 mm
Neck dimensions: height	99 mm
Neck dimensions: angle	48 °
Remote control	Yes
Operating temperature range	-20...40 °C
Storage temperature range	-40...60 °C
Standards	IEC 60974-7

Neck dimensions, W-models:

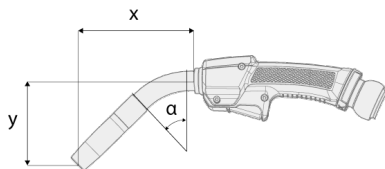

7.6 TECHNICAL DATA: FLEXLITE GXE 500A (WATER-COOLED)

Flexlite GXe 505W (3.5 m):

GXe 505W	
Feature	Value
Welding connection type	Euro
Type of cooling	Liquid
Contact tip	M10x1
Method of guidance	Manual
Load capacity 100% / Ar + 18% CO ₂	500 A
Load capacity test, filler wire material	Fe
Load capacity test, filler wire diameter	1.6 mm
Load capacity test, stick out length	22 mm
Load capacity test, gas flow	20 l/min
Filler wire diameter, Fe	0.8...1.6 mm
Filler wire diameter, Ss	0.8...1.6 mm
Filler wire diameter, Al	0.8...1.6 mm
Filler wire diameter, Fe-MC/FC	0.9...1.6 mm
Filler wire diameter, Ss-MC/FC	0.9...1.6 mm
Coolant flow rate	1 l/min
Minimum cooling power at 1 l/min	0.9 kW
Maximum coolant pressure	5 Bar
Gun handle	Yes
Neck type	Standard
Neck dimensions: length	163 mm
Neck dimensions: height	105 mm
Neck dimensions: angle	48 °
Remote control	Optional
Operating temperature range	-20...40 °C
Storage temperature range	-40...60 °C
Standards	IEC 60974-7

Flexlite GXe 505W (5 m):

GXe 505W	
Feature	Value
Welding connection type	Euro
Type of cooling	Liquid

Contact tip	M10x1
Method of guidance	Manual
Load capacity 100% / Ar + 18% CO ₂	500 A
Load capacity test, filler wire material	Fe
Load capacity test, filler wire diameter	1.6 mm
Load capacity test, stick out length	22 mm
Load capacity test, gas flow	20 l/min
Filler wire diameter, Fe	0.8...1.6 mm
Filler wire diameter, Ss	0.8...1.6 mm
Filler wire diameter, Al	0.8...1.6 mm
Filler wire diameter, Fe-MC/FC	0.9...1.6 mm
Filler wire diameter, Ss-MC/FC	0.9...1.6 mm
Coolant flow rate	1 l/min
Minimum cooling power at 1 l/min	0.9 kW
Maximum coolant pressure	5 Bar
Gun handle	Yes
Neck type	Standard
Neck dimensions: length	163 mm
Neck dimensions: height	105 mm
Neck dimensions: angle	48 °
Remote control	Optional
Operating temperature range	-20...40 °C
Storage temperature range	-40...60 °C
Standards	IEC 60974-7

Flexlite GXe 508WA (3.5 m):

GXe 508WA (+GRe80)	
Feature	Value
Welding connection type	Euro
Type of cooling	Liquid
Contact tip	M10x1
Method of guidance	Manual
Load capacity 100% / Ar + 18% CO ₂	500 A
Load capacity test, filler wire material	Fe
Load capacity test, filler wire diameter	1.6 mm
Load capacity test, stick out length	22 mm
Load capacity test, gas flow	20 l/min
Filler wire diameter, Fe	0.8...1.6 mm

Filler wire diameter, Ss	0.8...1.6 mm
Filler wire diameter, Al	0.8...1.6 mm
Filler wire diameter, Fe-MC/FC	0.9...1.6 mm
Filler wire diameter, Ss-MC/FC	0.9...1.6 mm
Coolant flow rate	1 l/min
Minimum cooling power at 1 l/min	0.9 kW
Maximum coolant pressure	5 Bar
Gun handle	Yes
Neck type	Standard
Neck dimensions: length	163 mm
Neck dimensions: height	105 mm
Neck dimensions: angle	48 °
Remote control	Yes
Operating temperature range	-20...40 °C
Storage temperature range	-40...60 °C
Standards	IEC 60974-7

Flexlite GXe 508WA (5 m):

GXe 508WA (+GRe80)	
Feature	Value
Welding connection type	Euro
Type of cooling	Liquid
Contact tip	M10x1
Method of guidance	Manual
Load capacity 100% / Ar + 18% CO ₂	500 A
Load capacity test, filler wire material	Fe
Load capacity test, filler wire diameter	1.6 mm
Load capacity test, stick out length	22 mm
Load capacity test, gas flow	20 l/min
Filler wire diameter, Fe	0.8...1.6 mm
Filler wire diameter, Ss	0.8...1.6 mm
Filler wire diameter, Al	0.8...1.6 mm
Filler wire diameter, Fe-MC/FC	0.9...1.6 mm
Filler wire diameter, Ss-MC/FC	0.9...1.6 mm
Coolant flow rate	1 l/min
Minimum cooling power at 1 l/min	0.9 kW
Maximum coolant pressure	5 Bar
Gun handle	Yes

Neck type	Standard
Neck dimensions: length	163 mm
Neck dimensions: height	105 mm
Neck dimensions: angle	48 °
Remote control	Yes
Operating temperature range	-20...40 °C
Storage temperature range	-40...60 °C
Standards	IEC 60974-7

Neck dimensions, W-models:

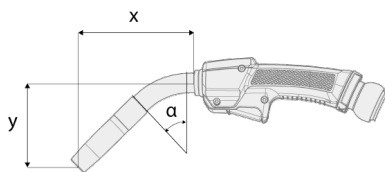

7.7 COMPONENT SELECTION

The following table lists the Flexlite GXe gas nozzles and contact tips in the factory setup.

Model	Gas nozzle	Contact tip
GXe 223G	22/14 L59 (L2)	1.0C1 L+, M10
GXe 253G	18/14 L61	1.0C1 STD, M6
GXe 323G	25/15 L59 (L2)	1.0C1 L+, M10
GXe 403GMN	28/15 L62 (L2)	1.2C1 L+, M10
GXe 423G	28/15 L62 (L2)	1.2C1 L+, M10
GXe 205G	22/14 L59 (L2)	1.0C1 L+, M10
GXe 305G	25/15 L59 (L2)	1.0C1 L+, M10
GXe 405G	28/15 L62 (L2)	1.2C1 L+, M10
GXe 305W	22/14 L59 (L2)	1.0C1 L+, M10
GXe 405W	25/15 L59 (L2)	1.2C1 L+, M10
GXe 505W	28/15 L62 (L2)	1.2C1 L+, M10
GXe 308GA	25/15 L59 (L2)	1.0C1 L+, M10
GXe 408GA	28/15 L62 (L2)	1.2C1 L+, M10
GXe 308WA	22/14 L59 (L2)	1.0C1 L+, M10
GXe 408WA	25/15 L59 (L2)	1.2C1 L+, M10
GXe 508WA	28/15 L62 (L2)	1.2C1 L+, M10

Gas nozzle: **OD/D L**

The markings in the gas nozzle specification stand for: OD = outer diameter (at the widest point), D = diameter (inner diameter of the gas nozzle tip), L = length, L1/L2/L3 = length class (L1 = short, L2 = medium, L3 = long).

In the contact tip specification: L+ = Life+ contact tip with longer life time, STD = standard.

Gas nozzle length class recommendation table

The following table lists the recommended gas nozzle length classes for different power levels and filler wire materials.

Power level	Filler wire material		
	Al	Fe	Ss
Low power (short arc / thin plate)	L3 (spatter protection)	L1 / L2 (good reach / spatter protection)	L1 (good reach)
Medium power / universal	L3 (spatter protection)	L2 (spatter protection)	L1 (good reach)
High power (spray arc / heavy duty use / thick plates)	L3 (spatter protection)	L3 (heat and spatter protection)	L1 / L2 (good reach / heat protection)

8. ORDERING INFORMATION

For Flexlite GXe ordering information and optional accessories, refer to [Kemppi.com](https://www.kemppi.com).