

MASTER M 358

MASTER M COOLER

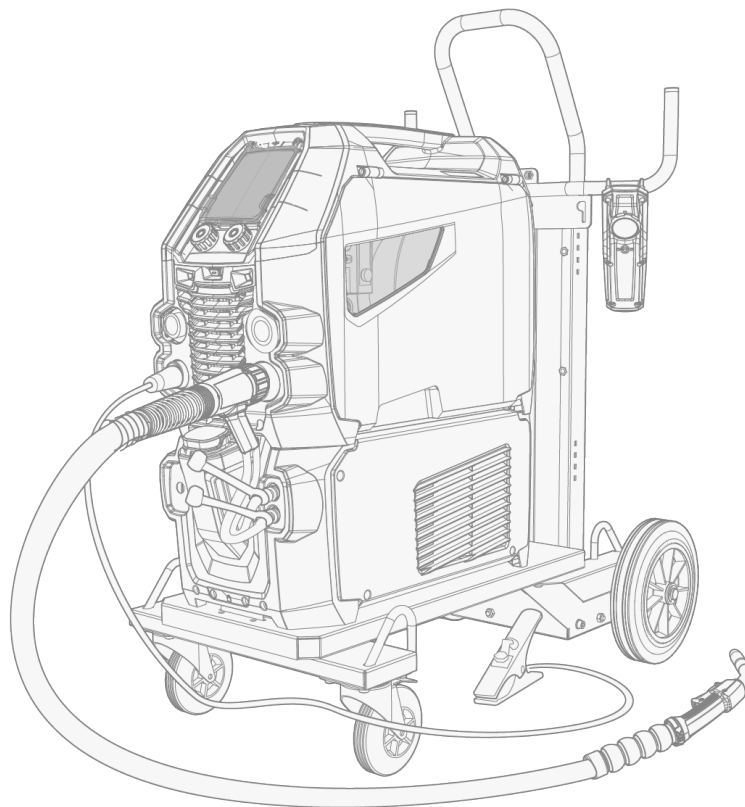

CONTENTS

1. General	4
1.1 Welding safety	5
1.2 Equipment description	6
1.3 Master M 358 device	8
1.3.1 Wire feed mechanism	10
1.3.2 Wire spools	10
1.3.3 Control panel	11
1.4 Master M Cooler cooling unit (optional)	12
2. Installation	13
2.1 Installing power source mains plug	14
2.2 Installing cooling unit (optional)	15
2.3 Installing equipment on cart (optional)	17
2.4 Connecting welding torch	19
2.5 Installing earth return cable	20
2.6 Installing remote control (optional)	21
2.7 Installing and replacing feed rolls	22
2.8 Installing and replacing wire guide tubes	25
2.9 Installing and changing wire	26
2.10 Installing gas bottle and testing gas flow	31
2.11 How to get welding programs	33
3. Operation	34
3.1 Preparing welding system for use	35
3.1.1 Filling cooler and circulating coolant	36
3.2 Calibrating welding cable	37
3.3 Using control panel	38
3.3.1 Control panel: Home view	39
3.3.2 Control panel: Weld Assist	40
3.3.3 Control panel: Channels	42
3.3.4 Control panel: WPS view	44
3.3.5 Control panel: WeldEye	47
3.3.6 Control panel: Welding parameters	54
3.3.7 Control panel: Weld history	62
3.3.8 Control panel: Info view	62
3.3.9 Control panel: Device settings	63
3.3.10 Control panel: Applying welding programs	66
3.3.11 Control panel: Weld data view	68
3.4 Additional guidance to functions and features	69

3.4.1 Trigger logic functions	69
3.4.2 1-MIG	70
3.4.3 WiseFusion feature	70
3.4.4 WisePenetration feature	71
3.4.5 WiseSteel feature	71
3.4.6 Pulse welding	72
3.4.7 MAX Cool process	72
3.4.8 MAX Position process	73
3.4.9 MAX Speed process	73
3.4.10 Wireless connection (WLAN)	74
3.4.11 Digital Welding Procedure Specification (dWPS)	75
3.4.12 WeldEye	76
3.4.13 WeldEye ArcVision	76
3.4.14 WeldEye with DCM	77
3.4.15 USB backup and restore	78
3.4.16 USB update	79
3.4.17 Cycle timer	80
3.4.18 Demo time	80
3.4.19 Settings lock	81
3.5 Using remote control HR43/HR40	82
3.6 Using remote control HR55	83
3.7 Changing welding polarity	85
3.8 Lifting equipment	87
4. Maintenance	88
4.1 Daily, periodic and annual maintenance	89
4.2 Installing and cleaning power source air filter (optional)	91
4.3 Troubleshooting	93
4.3.1 Error codes	94
4.4 Disposal	97
5. Technical data	98
5.1 Master M 358 device	99
5.2 Master M cooling unit	104
5.3 Master M 358 ordering info	105
5.4 Wire feeder consumables	106
5.5 Welding program work packs	108

1. GENERAL

These instructions describe the use of Kemppi's Master M 358 welding equipment designed for both normal and pulsed MIG/MAG welding.

The equipment consists of a power source (with an integrated wire feeder) and an optional cooling unit.

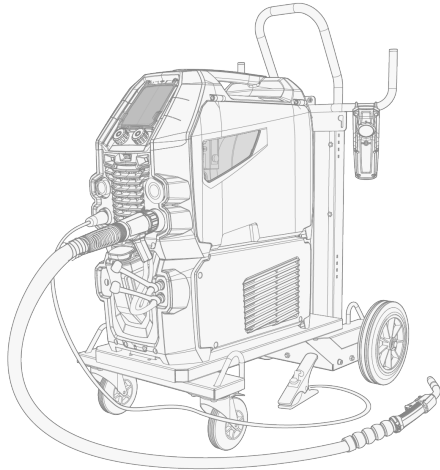

Master M 358 is designed to be used together with Kemppi's Flexlite GX MIG welding torches with Euro connector.

Master M 358 can be used also for TIG * and MMA ** welding.

* TIG welding requires the use of a dedicated Flexlite TX TIG torch with Euro connector.

** MMA welding requires a dedicated DIX-Euro adapter.

Important notes

Read the instructions through carefully.

Items in the manual that require particular attention in order to minimize damage and harm are indicated with the below symbols. Read these sections carefully and follow their instructions.

 *Note: Gives the user a useful piece of information.*

 *Caution: Describes a situation that may result in damage to the equipment or system.*

 *Warning: Describes a potentially dangerous situation. If not avoided, it will result in personal damage or fatal injury.*

DISCLAIMER

While every effort has been made to ensure that the information contained in this guide is accurate and complete, no liability can be accepted for any errors or omissions. Kemppi reserves the right to change the specification of the product described at any time without prior notice. Do not copy, record, reproduce or transmit the contents of this guide without prior permission from Kemppi.

The source language for this document is English. All other language versions available are either professional human translations or advanced machine translations. Any feedback regarding translation terminology can be sent to userdoc@kemppi.com.

1.1 WELDING SAFETY

Welding is always classified as hot work, and welding equipment typically contains high-voltage circuits. If you are not familiar with welding and welding principles, it is recommended that you acquire welding training or professional guidance before commencing welding. The welding equipment mentioned in this manual is intended for professional use in an industrial environment.

 *For your own safety, and that of your working environment, pay particular attention to the safety instructions delivered with the equipment.*

You can also access and download the safety instructions by using these links:

- [Safety](https://kemp.cc/safety/general)
(<https://kemp.cc/safety/general>)
- [Personal protection](https://kemp.cc/safety/ppe)
(<https://kemp.cc/safety/ppe>)
- [Welding guns and torches](https://kemp.cc/safety/torches)
(<https://kemp.cc/safety/torches>)

1.2 EQUIPMENT DESCRIPTION

Master M 358 device models (350 A)

- Master M 358 G
 - >> Generator compatible
 - >> Pulse device with automatic 1-MIG and pulse processes. Advanced MAX processes as optional.
- Master M 358 GM
 - >> Generator compatible and multi-voltage
 - >> Pulse device with automatic 1-MIG and pulse processes. Advanced MAX processes as optional.

Both Master M 358 device models have a 4-roll wire feed mechanism with the maximum wire spool diameter of 300 mm.

For the Master M 358 device part descriptions, refer to "Master M 358 device" on page 8.

Master M 358 control panels

- 2-knob 5.7" TFT/LCD control panel

Master M cooling units

- Master M Cooler
- Master M Cooler MV (multi-voltage).

For the cooling unit part descriptions, refer to "Master M Cooler cooling unit (optional)" on page 12.

MIG welding torches

- Flexlite GX welding torches with Euro connector.

For more information on the Flexlite GX welding torches, refer to [Kemppi Userdoc](#).

Subfeeders

 *Subfeeder support can be added with a separate installation kit (contact your Kemppi dealer / service workshop for more information).*

- SuperSnake GTX subfeeder

For more information on the SuperSnake GTX subfeeder, refer to [Kemppi Userdoc](#).

Welding programs

- Welding program work pack (factory-installed by default)
- 1-MIG Wise features: WiseSteel and WiseFusion (with welding program work pack)
- 1-MIG Wise features: WisePenetration (optional extra)
- Additional 1-MIG welding programs (optional extras)
- Additional advanced welding processes: MAX Cool, MAX Speed and MAX Position (optional extras).

The welding programs included in the Master M work packs are shown here: "Welding program work packs" on page 108.

For more information on acquiring welding programs and additional welding processes, contact your local Kemppi dealer.

Optional accessories

- 4-wheel carts
- 2-wheel carts
- Remote control HR40 (2-knob control)
- Remote control HR43 (1-knob control)
- Remote control HR55
- Wire feeder cabinet heater

- Power source air filter

For more information on optional accessories, contact your local Kempfi dealer.

EQUIPMENT IDENTIFICATION

Serial number

Serial number of the device is marked on the rating plate or in another distinctive location on the device. It is important to make correct reference to the serial number of the product when ordering spare parts or making repairs for example.

Quick Response (QR) code

The serial number and other device-related identification information may also be saved in the form of a QR code (or a barcode) on the device. Such code can be read by a smartphone camera or with a dedicated code reader device providing fast access to the device-specific information.

1.3 MASTER M 358 DEVICE

Front

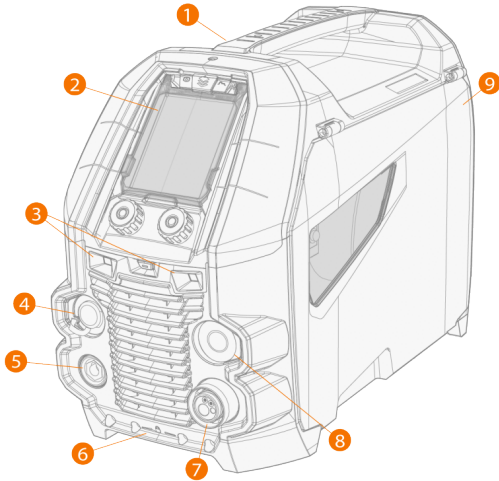

1. Transportation handle (also for mechanical lifting when the device is not installed on a cooling unit or cart)
2. Control panel (and hinged control panel cover)
3. Work lights with light switch in the middle
 - >> Light switch: First press turns the lights on (full brightness), second press dims the lights (medium brightness), third press turns the lights off
 - >> Includes a built-in battery (the battery is charged when the equipment is connected to mains)
4. Control cable connector
5. Earth return cable connector
6. Front locking interface
 - >> For locking on top of the cooling unit or on the cart
7. Welding cable Euro connector
8. Subfeeder synchronization connector
9. Wire feed cabinet hatch.

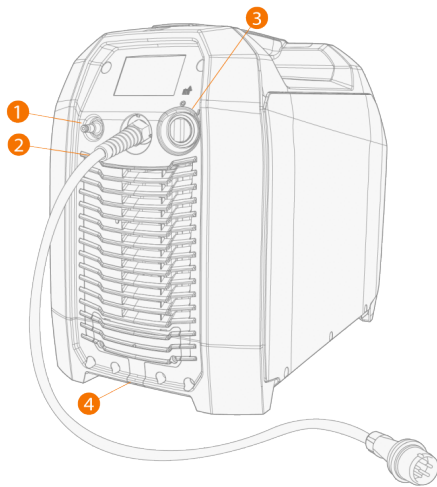
Rear

1. Shielding gas hose connector.
2. Mains cable
3. Power switch
4. Rear locking interface
 >> For locking on top of the cooling unit or on a cart.

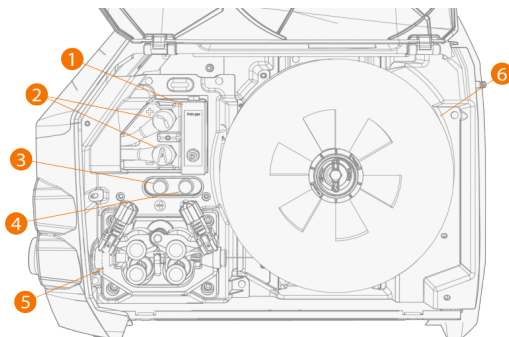
Inside wire feed cabinet

1. Rotameter for gas
2. Polarity terminals
3. Wire inch button
 >> Drive the filler wire forward (with arc off)
4. Gas test button
 >> Test the shielding gas flow and flush the gas line
5. Wire feed mechanism (refer to "Wire feed mechanism" on the next page)
6. Wire spool.

1.3.1 WIRE FEED MECHANISM

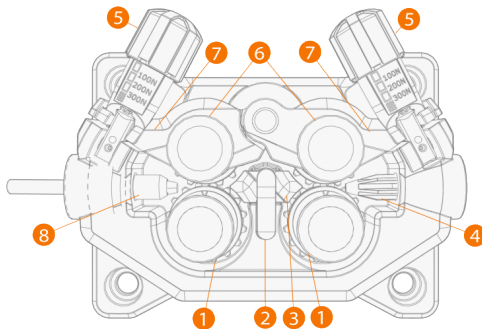

1. Drive rolls and drive roll mounting caps
2. Middle guide tube locking clip
3. Middle guide tube
4. Inlet guide tube
5. Pressure handles
6. Pressure rolls and pressure roll mounting pins
7. Pressure roll locking arms
8. Outlet guide tube.

For replacing the feed rolls, refer to "Installing and replacing feed rolls" on page 22.

For replacing the wire guide tubes, refer to "Installing and replacing wire guide tubes" on page 25.

1.3.2 WIRE SPOOLS

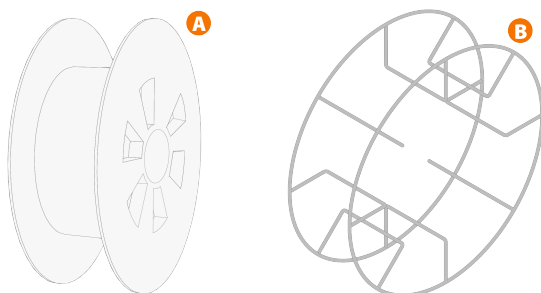

Master M uses the standard wire spools (A) without additional adapters. Wire spools with a large center hole, e.g. a wire basket rim (B), require an additional spool adapter (available as Kemppe accessory):

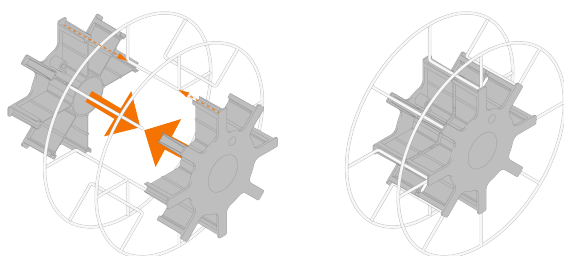

For more information, refer to "Installing and changing wire" on page 26.

1.3.3 CONTROL PANEL

This section describes the controls and features of the Master M 358 control panel (TFT/LCD).

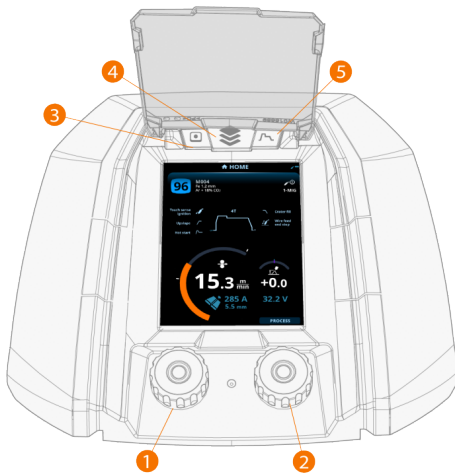

1. Left control knob (with push button function)
2. Right control knob (with push button function)
3. Memory channel selection (shortcut button)
4. View selection (shortcut button)
5. Welding parameters view (shortcut button).

For using the control panel, refer to "Using control panel" on page 38.

1.4 MASTER M COOLER COOLING UNIT (OPTIONAL)

Front

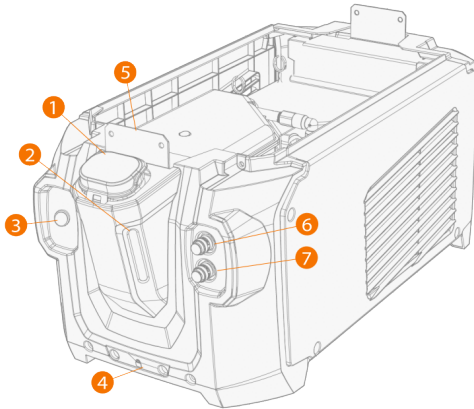

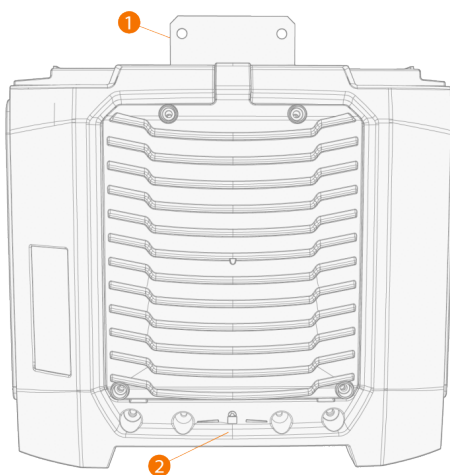

1. Cooler container cap
2. Cooling liquid level indicator
3. Cooling liquid circulation button
>> Keeping the button pressed activates the pump and circulates the cooling liquid throughout the system. Once released, the pump stops.
4. Front locking interface
>> For locking on the cart
5. Front locking interface
>> For locking to the power source
6. Coolant inlet connector (red)
7. Coolant outlet connector (blue).

Rear



1. Rear locking interface
>> For locking to the power source
2. Rear locking interface
>> For locking on the cart.



2. INSTALLATION

-  *Do not connect the equipment to the mains before the installation is complete.*
-  *Do not modify the welding equipment in any way, except for the changes and adjustments covered in the manufacturer's instructions.*
-  *Place the machine on a horizontal, stable and clean ground. Protect the machine from rain and direct sunshine. Check that there is enough space for cooling air circulation in the machine vicinity.*

Before installation

- Make sure to acknowledge and follow the local and national requirements regarding installation and use of high voltage units.
- Check the contents of the packages and make sure the parts are not damaged.
- Before you install the power source on site, see the requirements for the mains cable type and fuse rating.

Distribution network

-  *This Class A equipment is not intended for use in residential locations where the electrical power is provided by the public low-voltage supply system. There can be potential difficulties in ensuring electromagnetic compatibility in those locations, due to conducted as well as radiated radio-frequency disturbances.*
-  *Master M power source 350A: Provided that the short circuit power of public low voltage system at the point of common coupling is higher than 2.4 MVA, this equipment is compliant with IEC 61000-3-11:2017 and IEC 61000-3-12:2011 and can be connected to public low voltage systems. It is the responsibility of the installer or user of the equipment to ensure, by consultation with the distribution network operator if necessary, that the system impedance complies with the impedance restrictions.*

2.1 INSTALLING POWER SOURCE MAINS PLUG

 *Only an authorized electrician is allowed to install the mains cable and plug.*

 *Do not connect the machine to the mains before the installation is complete.*

Install the 3-phase plug according to the Master M device and site requirements.

The mains cable includes the following wires:

1. Brown: L1
2. Black: L2
3. Grey: L3
4. Yellow-green: Protective earth

Cable type and fuse rating requirements:

Unit amperage	Cable type	Fuse rating
350 A (380-460 V)	4 mm ²	16 A
350 A (380-460 / 220-230 V)	4 mm ²	16 / 32 A

2.2 INSTALLING COOLING UNIT (OPTIONAL)

 *The Master M cooling unit must be installed by authorized service personnel.*

Tools needed:



1. Remove the small connector cover in the rear of the power source.

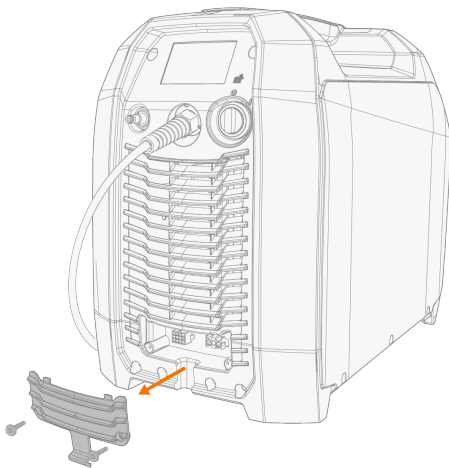

2. Route the cooling unit's connection cables so that they remain accessible through the next steps.
3. Lift the Master M device on top of the cooling unit so that the fixing plates align and go into their slots.

 *Ensure that the cooling unit's connection cables are not caught and/or damaged between the edges.*

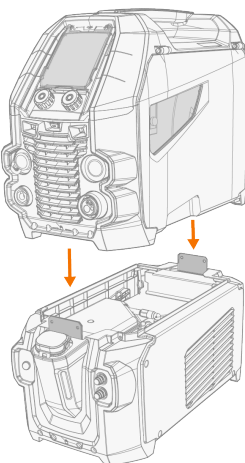

4. Fix the units together with two screws (M5x12) in the front and two screws (M5x12) in the rear.
5. Connect the cooling unit cables.

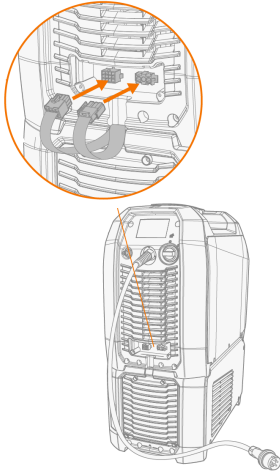

6. Replace the small connector cover.

2.3 INSTALLING EQUIPMENT ON CART (OPTIONAL)

Master M has four transport unit options: a 4-wheel cart with a gas bottle rack (P45MT), a 4-wheel cart without a gas bottle rack (P43MT), a 2-wheel cart with a gas bottle rack (T25MT) and a 2-wheel cart without a gas bottle rack (T35A).

i *The equipment installation principle and the bottom securing interface is the same with all carts.*

Tools needed:



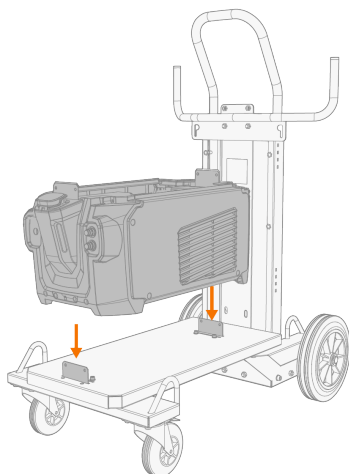

1. Install the cooling unit on the cart.

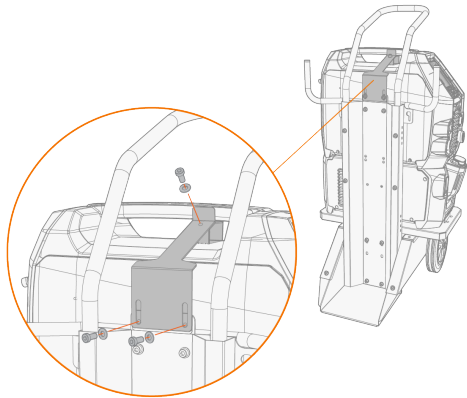

2. Fix the cooling unit to the cart with two screws (M5x12) in the front and two screws (M5x12) in the rear.
3. Install the Master M device on top of the cooling unit. Refer to "Installing cooling unit (optional)" on page 15 for installation details.
4. T25MT 2-wheel cart: Secure the equipment to the cart with the two side connection brackets.

i *With the T25MT cart, an additional securing bracket is attached to the device handle. Secure the bracket to the cart with the screws provided (M8x16).*



 **T35A 2-wheel cart:** *The cart must be in horizontal position during welding.*

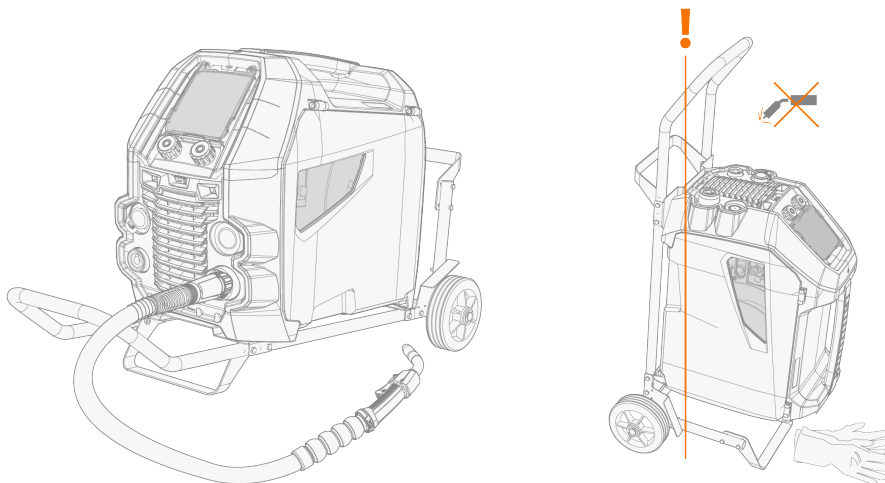

For lifting the Master M equipment, refer to "Lifting equipment" on page 87.

2.4 CONNECTING WELDING TORCH

Master M is designed to be used with the Kemppi Flexlite GX welding torches. For the Flexlite GX operating instructions, refer to userdoc.kemppi.com.

i Always check that the wire liner, contact tip and gas nozzle are suitable for the job.

1. Push the welding torch connector into the Euro connector and hand-tighten the collar.
2. If your setup includes a power source with cooling unit and a water-cooled torch, connect also the cooling liquid hoses. The hoses are color-coded.

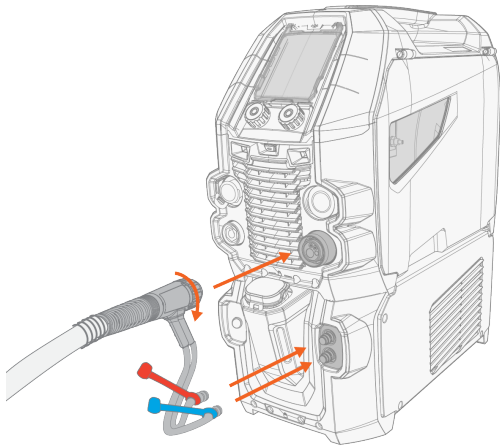

3. Install and load the filler wire as described in "Installing and changing wire" on page 26.
4. Check the gas flow. Refer to "Installing gas bottle and testing gas flow" on page 31 for more information.

2.5 INSTALLING EARTH RETURN CABLE

1. Connect the earth return cable to the Master M machine's earth return cable connector.

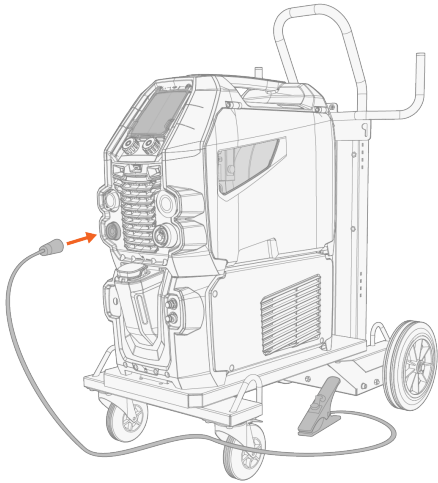

2.6 INSTALLING REMOTE CONTROL (OPTIONAL)

Remote controls are optional. To enable remote operation, connect the remote control device to the Master M welding equipment.

Remote control HR43/HR40

1. Connect the remote control cable to the power source's control cable connector.

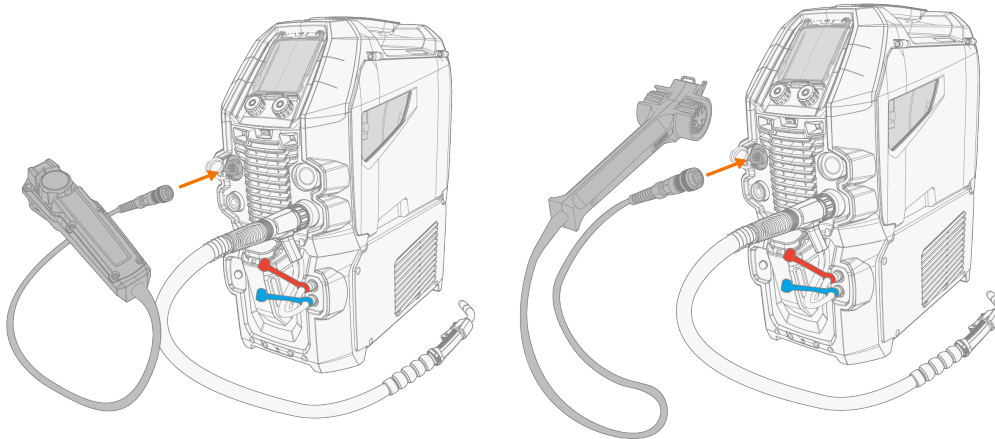

2. To adjust the remote control parameters, refer to the control panel settings ("Control panel: Device settings" on page 63).

The remote control mode can be set and adjusted in the control panel settings.

Remote control HR55

1. Connect the remote control cable to the power source's control cable connector.

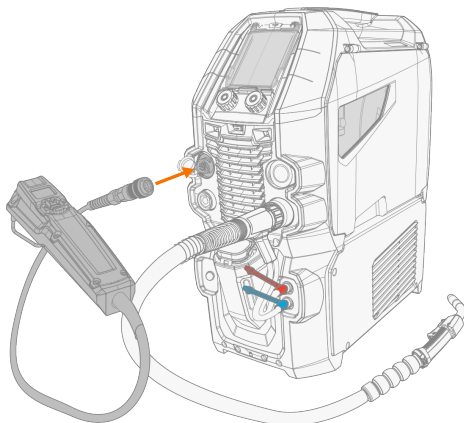

The remote control selections in the control panel settings are not required with HR55 remote control. When connected, the HR55 remote control is automatically in use.

2.7 INSTALLING AND REPLACING FEED ROLLS

Replace the feed rolls when the filler wire diameter or material changes. Select the feed rolls according to the tables in "Wire feeder consumables" on page 106.

1. Open the wire feed cabinet hatch.
2. Release the pressure handles on the wire feed mechanism.

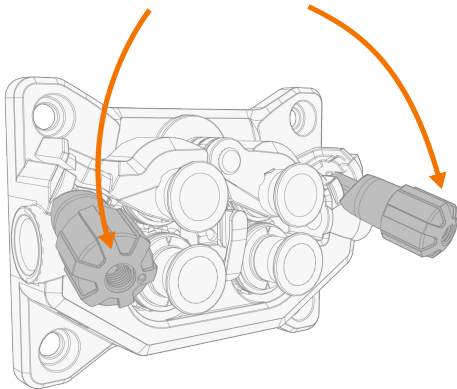

3. Open the locking arms to release the feed rolls.

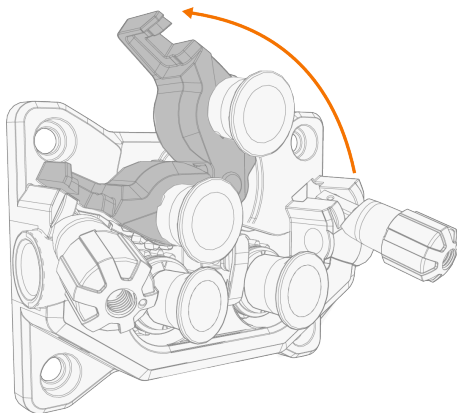

4. Remove the pressure feed roll mounting pins by pulling them.

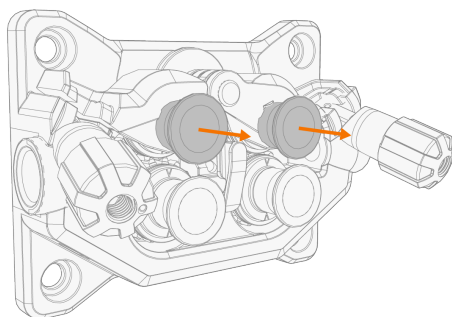

i The pressure rolls' mounting pins have central axles attached to them, whereas the drive rolls' central axles act as drive shafts attached directly to the wire feed mechanism/motor.

5. Remove the pressure rolls.

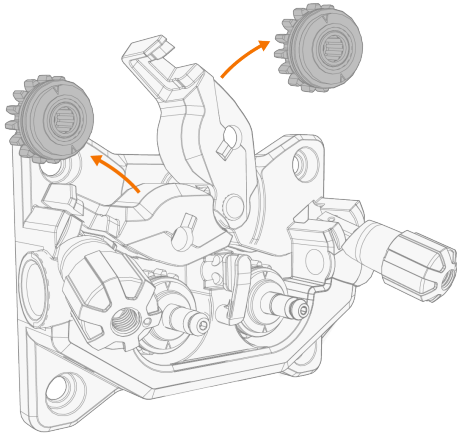

6. Remove the drive feed roll mounting caps by turning and pulling them.

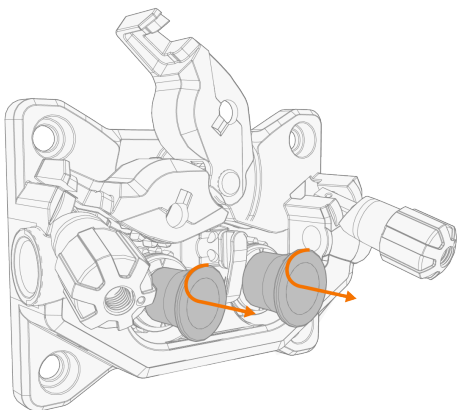

7. Remove the drive feed rolls.

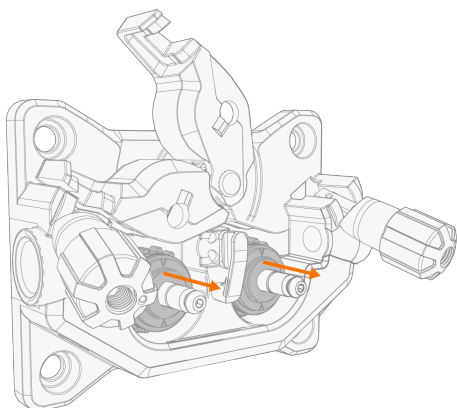

8. Follow the previous steps in reverse to install the wire feed rolls. Align the cut on the drive rolls' bottom with the pin on the drive shaft.
9. Reattach the mounting caps and mounting pins to lock the drive and pressure rolls into their places.
10. Close the locking arms and lower the pressure handles on the feed rolls. Refer to "Installing and changing wire" on page 26 for more information on the wire installation.
11. Close the wire feed cabinet hatch.

2.8 INSTALLING AND REPLACING WIRE GUIDE TUBES

The wire feed mechanism includes three wire guide tubes. Replace them when the filler wire diameter or material changes. Select the wire guide tubes according to the tables in "Wire feeder consumables" on page 106.

 When replacing the outlet guide tube, the welding gun must be detached.

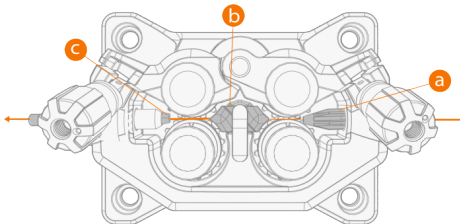

- a. Inlet guide tube
- b. Middle guide tube
- c. Outlet guide tube

To replace the wire guide tubes:

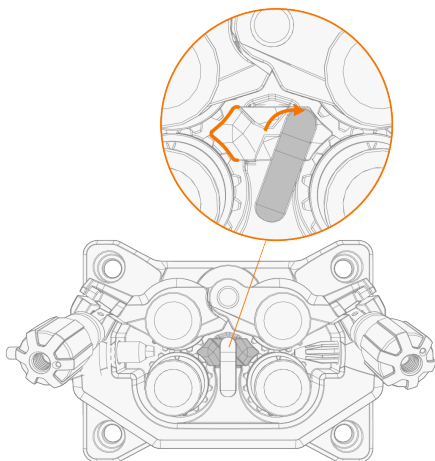

1. Release the pressure arms and remove the filler wire from the system.
2. Pull out the inlet guide tube (a) and insert a new one in its place.
3. Turn the locking clip aside to free the middle guide tube (b) for replacement.
4. Insert a new middle guide tube in its slot and push it properly in place. Ensure that the mark arrow points to the wire running direction.



5. Turn the locking clip back to lock down the new middle tube.
6. Replace the outlet guide tube (c) by pushing the old outlet tube out from either direction.

2.9 INSTALLING AND CHANGING WIRE

Always ensure that the feed rolls are suitable for the filler wire (diameter and material) in question. For more information, refer to "Wire feeder consumables" on page 106.

-  *Install the welding torch to the Master M device before installing the wire spool.*
-  *When changing the wire spool, remove the remaining filler wire from the welding torch and wire feed mechanism before removing the wire spool.*

To remove the wire spool:

1. Open the wire feed cabinet hatch.
2. Loosen and remove the spool fastener and remove the wire spool.

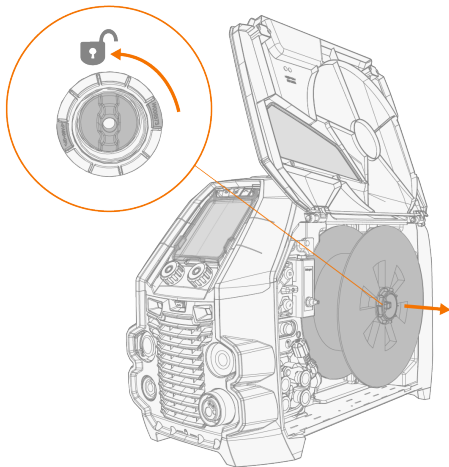

To install the wire spool:

1. Insert the wire spool onto the hub. Secure the wire spool in place by inserting and tightening the spool fastener.
-  *Ensure that the wire spool is facing the right direction, the filler wire running from the bottom of the spool to the feed rolls.*

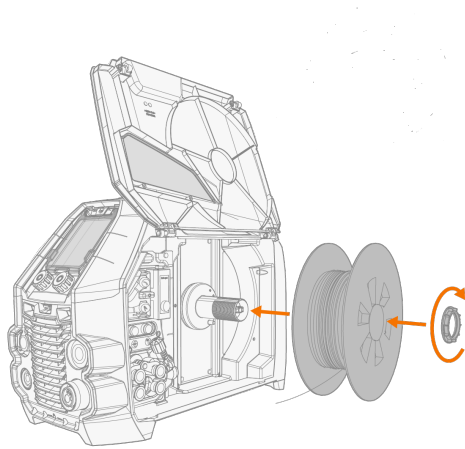

- i** When installed, the pin next to the wire spool hub in the wire feeder must align and go into the hole in the spool or spool adapter.

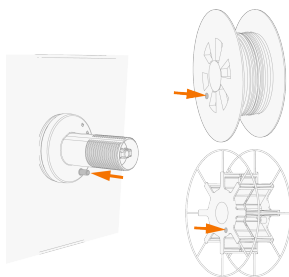

- 2.** If needed, adjust the spool brake by turning the spool brake tightening knob in the center of the spool hub.

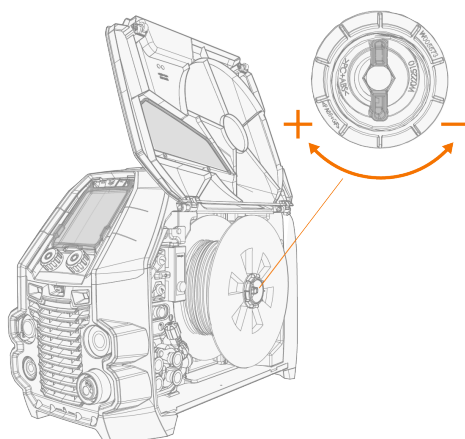



To install the filler wire:

- 1.** Release the filler wire end from the spool and cut off any deformed section so that the end is straight.

- i** Ensure that the filler wire does not spill from the spool when it is released.

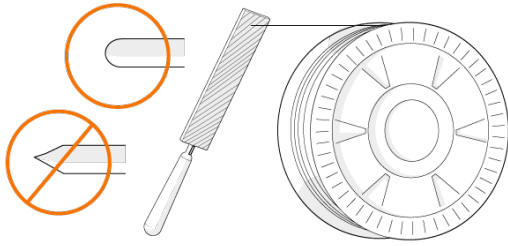
2. File the tip of the filler wire smooth.



 *Sharp edges on the filler wire tip may damage the wire liner.*

3. Release the pressure arms to move the feed rolls apart.

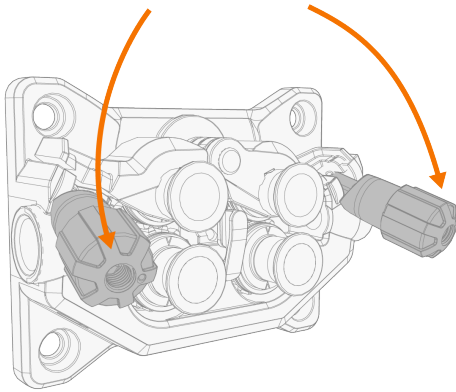

4. Guide the filler wire through the inlet guide tube (a) and middle guide tube (b) and into the outlet guide tube (c), which feeds the filler wire to the welding torch.

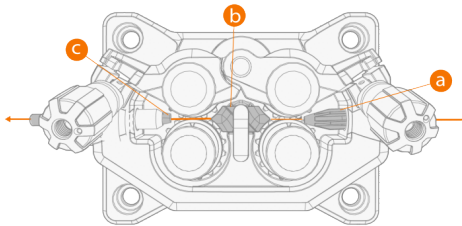

5. Push the filler wire by hand into the torch so that the wire reaches the wire liner.

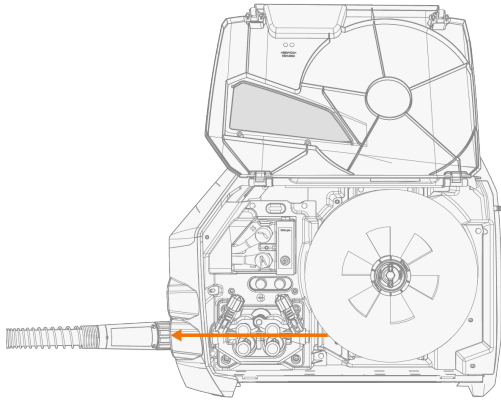

6. Close the pressure arms so that the filler wire is locked between the feed rolls.

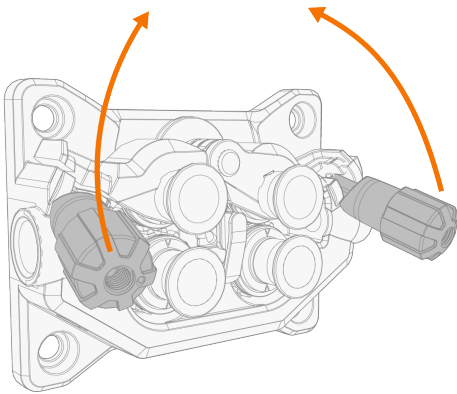

7. Adjust the pressure of the feed rolls with the pressure adjustment wheels. The pressure is the same for both feed roll pairs.

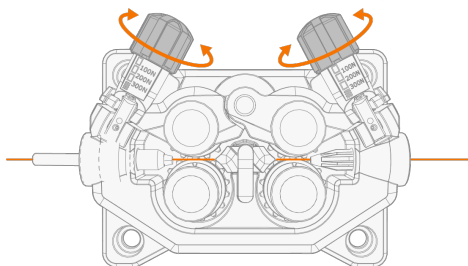

The graduated scales on the pressure handle indicate the pressure applied to the feed rolls.

Adjust the pressure of the feed rolls according to the table below.

Filler wire material	Feed roll profile*	Filler wire diameter (mm)	Adjustment (x100N)
Fe/Ss solid	V-groove	0.8-1.0	1.5-2.0
		≥ 1.2	2.0-2.5
MC/FC	V-groove, knurled	≥ 1.2	1.0-2.0
Al	U-groove	1.0	0.5-1.0
		1.2	1.0-1.5

 *Excessive pressure flattens the filler wire and may damage coated or cored filler wires. Excessive pressure also unnecessarily wears the feed rolls and increases gearbox load.*

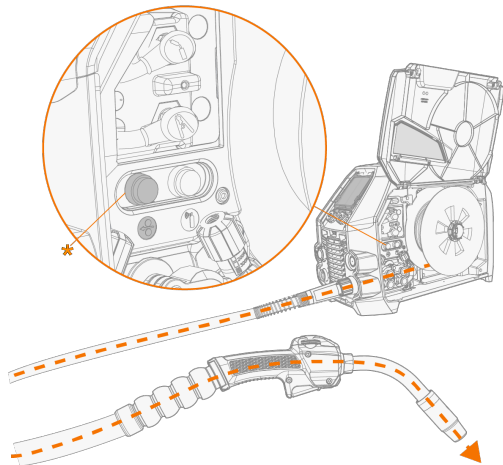

- Press the wire inch button (*) to drive the filler wire into the welding torch. Stop when the wire reaches the welding torch's contact tip. The wire feed speed can be adjusted in the control panel.





 *Watch out for the wire when it reaches the contact tip and exits the torch.*

- Before welding, ensure that the welding parameters and settings conform to your welding setup.

* Feed roll profiles and corresponding symbols

Feed roll profile	Symbol
V-groove	
V-groove, knurled	
U-groove	

2.10 INSTALLING GAS BOTTLE AND TESTING GAS FLOW

-  *Handle gas bottles with care. There is a risk of injury if the gas bottle or the bottle valve is damaged!*
-  *Always secure the gas bottle properly in an upright position to a special holder on the wall or on the welding equipment cart. Always keep the gas bottle valve closed when not welding.*
-  *- If a transport unit with a gas bottle rack is used, install the gas bottle on the transport unit first, then make the connections.*
 - Install the welding torch to the welding machine before installing and testing the gas bottle.*
 - Do not use the whole contents of the bottle.*
 - Always use an approved and tested regulator and flow meter.*

Contact your local Kemppi dealer for choosing the gas and the equipment.

1. Without gas bottle cart: Place the gas bottle in a suitable, secure location.
2. With gas bottle cart: Move the gas bottle on the transport unit's gas bottle rack and secure it in place with the straps and fixing points provided.

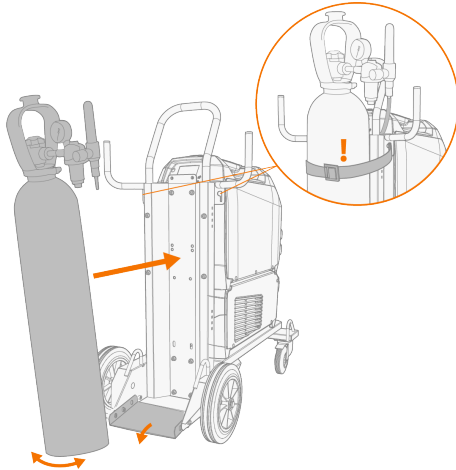

3. If not already, connect the welding gun to the device (refer to "Connecting welding torch" on page 19).
4. Connect the gas hose to the welding device.
5. Open the gas bottle valve.
6. Press the gas test button (*) to test and adjust the gas flow. Use either the built-in rotameter or an external flow meter and regulator for measuring and adjustment.

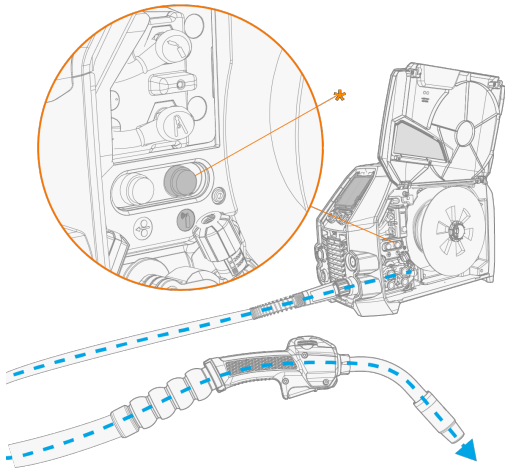

 The gas test time is 20 seconds by default. The time can be changed in the control panel.

Recommended gas flow rates (for general guidance only):

	TIG*	MIG**
Argon	5...15 l/min	10...25 l/min
Helium	15...30 l/min	-
Argon + 18-25% CO ₂	-	10...25 l/min
CO ₂	-	10...25 l/min

* Depending on the gas nozzle size.

** Depending on the gas nozzle size and welding current.

2.11 HOW TO GET WELDING PROGRAMS

The Master M 358 device comes with a welding program work pack preinstalled. These work pack versions cover the basic welding tasks with the automatic 1-MIG and pulsed welding process.

WisePenetration and MAX processes (MAX Cool, MAX Position, MAX Speed) are installed at the time of purchase according to your specific welding requirements. This can be done by your local Kemppi dealer. Welding programs can also be added later on.

For more information on the available welding program options and installing the welding programs or software updates, contact your local Kemppi dealer or go to [Kemppi.com](https://www.kemppi.com).

The manual MIG process doesn't require additional welding programs.





For applying the welding programs installed on your Master M 358 equipment, refer to "Control panel: Applying welding programs" on page 66.

The list of installed welding programs on your equipment can be seen in the control panel's Info view under **Welding software**.

The welding programs included in the Master M 358 work packs are shown here: "Welding program work packs" on page 108.

3. OPERATION

Before using the equipment, ensure that all the necessary installation actions have been completed according to your equipment setup and instructions.

-  *Welding is forbidden in places where there is an immediate fire or explosion hazard!*
-  *The wire feed cabinet hatch must be kept closed when welding.*
-  *Check that there is enough space for cooling air circulation in the machine vicinity.*
-  *If the welding equipment is left unused for a longer period, disconnect the mains plug from the mains.*
-  *Always check before use that shielding gas hose, earth return cable and clamp and mains cable are in serviceable condition. Ensure that the connectors are correctly fastened. Loose connectors can impair welding performance and damage connectors.*

3.1 PREPARING WELDING SYSTEM FOR USE

Before starting the use of the welding equipment:

- Ensure the installation has been completed
- Switch the welding equipment on
- Prepare the cooler
- Connect the earth return cable
- Calibrate the welding cable (in MIG operation mode only)
 - >> Refer to "Calibrating welding cable" on page 37 for instructions.

Turning on welding system

To turn on the welding equipment, turn the power source main switch to ON (I).

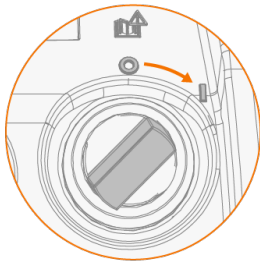

Turn the main switch to start and shut down the welding equipment. Do not use the mains plug as a switch.

-  *If the welder is left unused for a longer period, detach the mains plug to disconnect it from the mains.*

Preparing cooler

Fill the coolant container inside the cooler with Kemppi cooling liquid. For instructions on filling the cooler, refer to "Filling cooler and circulating coolant" on the next page. To weld, you must pump the coolant through the system by pressing the coolant circulation button in the front panel of the cooling unit.

Connecting earth return cable



-  *Keep the work piece connected to earth to reduce the risk of injury to users or damage to electrical equipment.*

Attach the earth return cable clamp on the work piece.

Ensure that the contact surface is clean of metal oxide and paint and that the clamp is firmly secured.

Selecting operation mode and process

To select the operation mode (MIG/TIG/MMA), refer to "Control panel: Device settings" on page 63.

-  *For TIG welding, the polarity (+/-) must be switched. For information, refer to "Changing welding polarity" on page 85.*
-  *In MMA welding, the VRD (Voltage Reduction Device) limits the open-circuit voltage to 24 V.*

3.1.1 FILLING COOLER AND CIRCULATING COOLANT

Fill the cooler with pre-mixed coolant solution. The mixing ratio should be 20...50% as standard. Use only ethylene or propylene glycol mixture intended for welding cooling systems, for example Kemppi cooling liquid.

 *Do not add water to the pre-mixed coolant solution. Do not use automotive cooling solutions or ethanol-based mixtures.*

1. Open the cooler cap.
2. Fill the cooler with coolant. Do not fill over the max. marking.

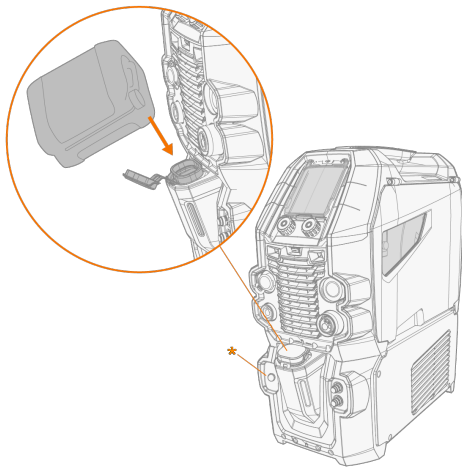

3. Close the cooler cap.

To circulate the coolant:

Press the coolant circulation button in the cooler front panel (*). It activates the motor, which pumps the coolant to the hoses and to the welding gun.

Complete the coolant circulation operation after each time you change the welding gun.

3.2 CALIBRATING WELDING CABLE

The welding cable resistance can be measured using the built-in cable calibration function without an additional measurement cable. This calibration function is available only in MIG operation mode.

1. Connect the earth return cable between the welding device and work piece.
2. Remove the welding torch gas nozzle.
3. Connect the welding torch to the welding device.
4. Turn the welding device on.
5. On the control panel, go to settings and enable cable calibration.
6. Touch the cleaned work piece briefly with the welding torch contact tip.

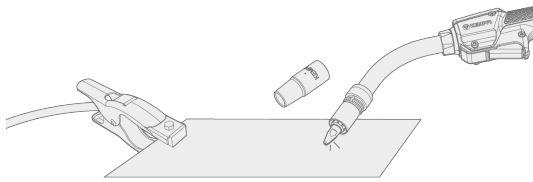

i *There is no need to press the trigger. Trigger function is disabled at this stage.*

7. Using the control panel, confirm the measured values.

3.3 USING CONTROL PANEL

The Master M 358 control panel includes advanced features and functions for MIG welding with the option to use Master M 358 also for TIG (DC) and MMA welding.

The automatic 1-MIG process is available along with the Kemppi welding programs as well as Wise features and MAX processes (optional). For more information, refer to "How to get welding programs" on page 33.



General

1. Left control knob
>> Adjustment and selection
2. Right control knob
>> Adjustment and selection
3. Memory channels button
>> Shortcut to the memory channel selection
>> Changed welding parameters can be quickly saved onto the active memory channel by keeping the Memory channels button pressed for approx. 2 seconds. This works in any view.
4. View menu button
>> Enter view selection

>> Long press of the button returns to Home view, or if already in Home view, to the last used view.

5. Welding parameters button

>> Shortcut to the welding parameters view

6. View selection

>> Change view by turning the control knob (2)

>> Confirm view change by pressing the control knob (2).

Safety lock: By long-pressing the control knobs 1 and 2 simultaneously, the device can be locked for safety. This prevents welding and operating the device by accident without having to turn the equipment off. Unlock the device by pressing the control knobs 1 and 2 simultaneously for 2 seconds.

Views (7)

- A. [Home view](#)
- B. [Weld Assist view](#)
- C. [Memory channels view](#)
- D. [WPS view](#)
- E. [Welding parameters view](#)
- F. [Weld history view](#)
- G. [Device settings view](#)
- H. [WLAN view](#)
- I. [Info view](#)
- J. [WeldEye view](#)

 After each weld, a weld summary ([Weld data](#)) is displayed briefly.

3.3.1 CONTROL PANEL: HOME VIEW

Master M 358 control panel's Home view is also the main welding view.

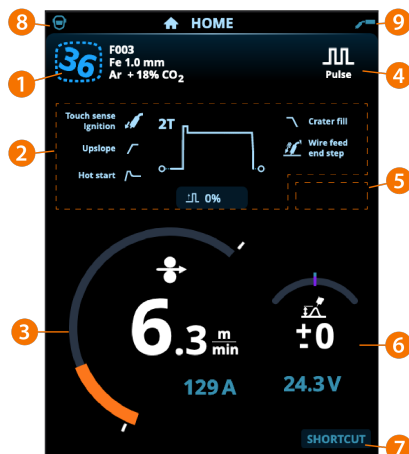

1. Memory channel information
2. Applied welding parameters and functions
3. Wire feed speed (MIG) or welding current (TIG, MMA)
4. Active welding process
5. Applied device settings (e.g. remote control or subfeeder)
6. Welding voltage
 - >> With 1-MIG process voltage fine tuning is displayed
 - >> With MAX process a corresponding MAX parameter adjustment is displayed.
7. Configurable function for the right control knob button

- >> To define a shortcut, keep the right control knob button pressed for 3 seconds and select the shortcut function from the list of available options.
- >> Once defined, the shortcut is used by short press of the right control knob button when in Home view.

8. Active user
9. Active operation mode.

Control knob functions in Home view

Left control knob:

- Manual MIG: Wire feed speed adjustment
- 1-MIG: Wire feed speed adjustment
- Pulse MIG: Wire feed speed adjustment
- DPulse MIG: Wire feed speed adjustment and switching between pulse levels with control knob button
- TIG/MMA: Welding current adjustment

Right control knob:

- Manual MIG: Welding voltage adjustment
- 1-MIG: Fine tuning of welding voltage or Wise/MAX parameter adjustment
- Pulse MIG: Fine tuning of welding voltage or Wise/MAX parameter adjustment
- DPulse MIG: Fine tuning of welding voltage
- MMA: Dynamics adjustment.



 *With Wise features or MAX processes turned on, the control knob functions in Home view and during welding may differ from the above. For more information on these features and processes, refer to "Additional guidance to functions and features" on page 69.*

3.3.2 CONTROL PANEL: WELD ASSIST

Weld Assist is a wizard-like utility for easy selection of welding parameters. The utility walks the user step-by-step through the selection of required parameters.

In Weld Assist, the selections are made with the two control knobs.

To use Weld Assist with MIG welding:

-  *The currently selected welding program, including filler wire and shielding gas information, is shown and used as a basis in Weld Assist. If necessary, the welding program can be changed before continuing by selecting 'Change welding program'.*
-  *If the currently selected welding program (on the active memory channel) is not supported by Weld Assist, the user is guided to change the welding program.*

1. To start, go to the **Weld Assist** view and select 'Next' with the control knob button.

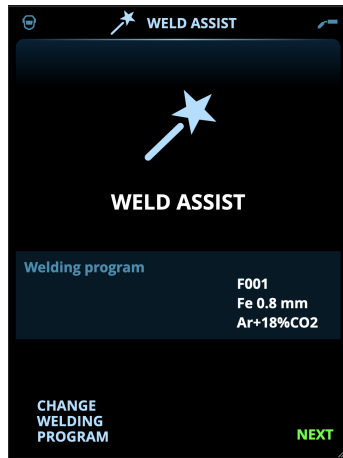

2. Select:

- >> The welding joint type: butt joint / corner joint / edge joint / lap joint / T-joint / tube joint / tube+plate joint.
- >> The welding position: PA / PB / PC / PD / PE / PF / PG
- >> The plate thickness (1...10 mm). Note: With PG position, the maximum plate thickness is 3 mm.

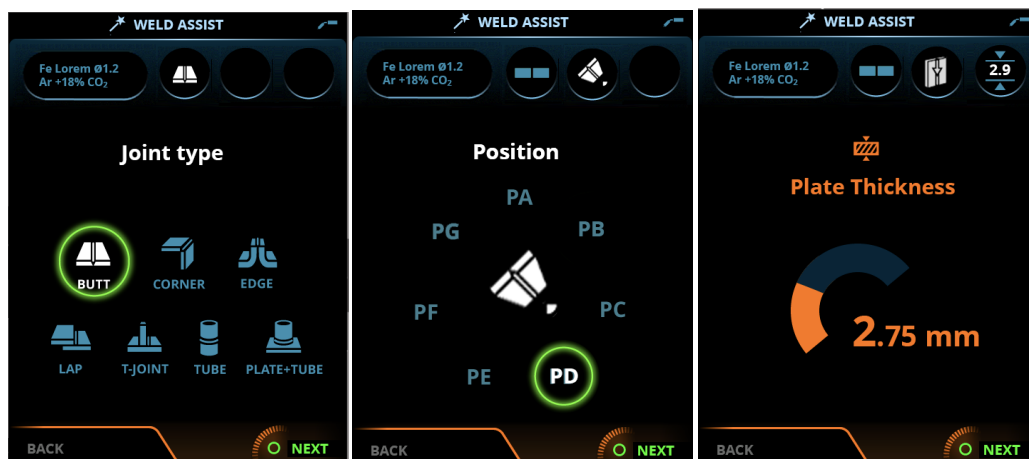

3. Weld Assist gives you a recommendation for these welding parameters:

- >> Welding process
- >> Wire feed speed
- >> Gas flow rate
- >> Travel speed
- >> Separate values for root and fill passes (where applicable).

4. Confirm the Weld Assist's recommendation for welding settings by selecting 'Save'.



5. Select the memory channel slot for saving.
6. Once saved, the memory channel can be taken into use by selecting **Use** in Weld Assist, or later in the **Memory channels** view.

The welding parameters created with Weld Assist are still adjustable as per normal.

Tip: You can go back step by step in Weld Assist by pressing the left control knob button.

3.3.3 CONTROL PANEL: CHANNELS

The memory channel view can be accessed either via the panel's view selection or by pressing the physical memory channel shortcut button above the display (refer to "Using control panel" on page 38 for more information).

The amount of available memory channels differs between different operation modes: MIG (100 channels), TIG (10 channels) and MMA (10 channels).

-  *The operation mode set in the control panel [Settings](#) determines for which main welding process the memory channels are shown.*



Changing memory channel

Turn the right control knob to highlight the desired memory channel. The highlighted memory channel is automatically activated.

Managing memory channels

The memory channels are managed through the **Actions** menu.

1. Enter the actions menu by pressing the right control knob.
2. Turn the control knob to highlight the desired action.
3. Select the action by pressing the right control knob.
4. Make further selections as required.

Available actions are:

- **Save changes:** Save changes to the currently selected channel
- **Save to...:** Save the current settings to another channel
- **Rename:** Rename the channel
- **Delete:** Delete the currently selected channel
- **Link to WPS:** Link the currently selected channel to a weld pass on a digital welding procedure specification (dWPS) document.
- **Create channel:** Create a new channel based on the welding program(s)
 - >> MIG only: Welding programs can be filtered by base material, wire material, wire diameter, shielding gas and process. For more information, refer to "Control panel: Applying welding programs" on page 66.
- **Create from programs:** Create new channels based on all of the unused welding programs available (in MIG mode only)
- **Delete all:** Delete all channels.

The skewed channel number in the top left corner of the channel selection indicates that the set welding parameters are different from the ones currently saved on the active memory channel:



Tip: Changed welding parameters can be quickly saved onto the active memory channel by keeping the Memory channels button pressed for approx. 2 seconds. This works in any view.

3.3.4 CONTROL PANEL: WPS VIEW

The use of digital WPS (Welding Procedure Specification, dWPS) and WeldEye cloud service require a valid Kemppi WeldEye subscription with the Welding Procedures module. The Master M 358 equipment includes a link to a free trial registration – featuring also a free trial option for WeldEye ArcVision. For more information on WeldEye, refer to weldeye.com or contact your Kemppi representative.



To take the digital WPS feature in use, the equipment must be connected to the internet via the built-in wireless connection (WLAN). Refer to "Wireless connection (WLAN)" on page 74 for instructions.

Trial registration

Master M 358 comes preinstalled with a trial license for the WeldEye Welding Procedures module. The trial license can be activated by following these steps:

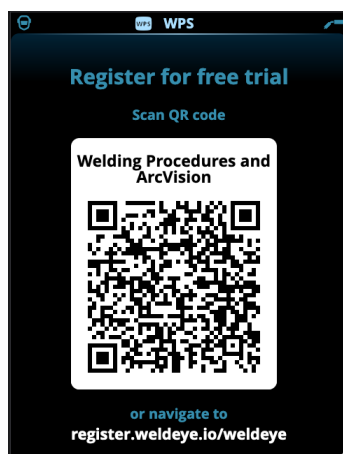
1. On the Master M 358 control panel, go to the **WPS view**.
2. Use a QR code reader on your mobile device to open the WeldEye web link or navigate to 'https://register.weldeye.io/weldeye' on your web browser.



3. Complete the registration process as instructed on the registration page.
 -  You will be required to fill in the serial number and four-digit security pin of your Master M 358 machine. These can be found on the machine rating plate.
 -  The free trial registration includes both the WeldEye Welding Procedures and WeldEye ArcVision modules.

Using dWPS

The **WPS view** shows the digital WPSs with one or more weld passes assigned to the welder or welding station in the Kemppi WeldEye cloud service.

To take a dWPS in use:

1. Select the desired dWPS for viewing and for selecting a weld pass by turning the right control knob and pressing the right control knob button.



- i** If a dWPS and weld pass have already before been linked to the active memory channel, the **WPS** view opens directly to that WPS. To open the list of available dWPSs, select 'Change WPS'.
2. Select a weld pass on the dWPS by turning the right control knob and enter the actions menu by pressing the right control knob button.



>> The linked memory channel set as default is emphasized for each weld pass.

- If a memory channel has been already linked to the weld pass, you can activate the selected weld pass and the default memory channel by selecting 'Activate'.

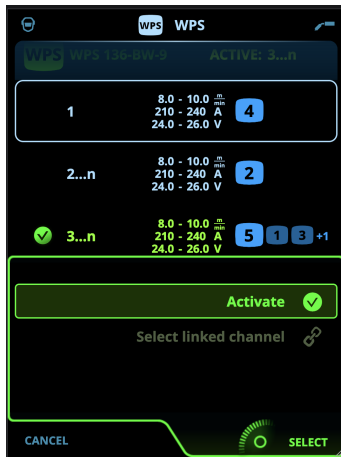

- If a memory channel has not been linked to the weld pass previously, you can link the weld pass to an existing memory channel ('Select linked channel').

 A memory channel can also be linked to a weld pass on a dWPS through the **Memory channels view** by selecting 'Link to WPS' in the memory channel's actions menu.

Once a weld pass on a dWPS is activated, the default memory channel linked to it is automatically selected. This is indicated also in the home view and on screen during welding.

The welding parameters are still manually adjustable, but the adjustment ranges defined on the active WPS are indicated on the screen. If you adjust the welding parameters outside the WPS adjustment range, the control panel shows a warning on the screen:



The active WPS can be deactivated by selecting 'Stop using' in the WPS's weld pass actions menu.

More feature descriptions here:

- >> "Digital Welding Procedure Specification (dWPS)" on page 75
- >> "WeldEye ArcVision" on page 76

3.3.5 CONTROL PANEL: WELDEYE

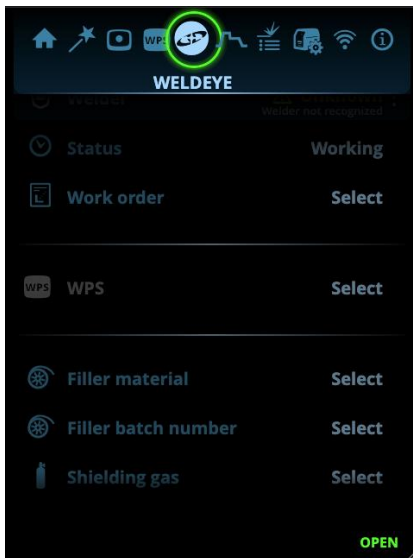



This chapter is about the optional WeldEye feature in Master M 358.

The use of this WeldEye feature and cloud service require an up-to-date Master M 358 equipment and a valid **Kemppi WeldEye Quality Management** subscription. For more information on WeldEye, refer to weldeye.com or contact your Kemppi representative.

The built-in WeldEye feature collects and passes on welding data, keeping it synchronized between the welding equipment and WeldEye cloud service. The WeldEye cloud service can be accessed using a desktop computer and an internet browser.

To take the WeldEye feature in use, the equipment must be connected to the internet via the built-in wireless connection (WLAN). Refer to "Wireless connection (WLAN)" on page 74 for instructions.

The welding equipment must also be added to your WeldEye account in the WeldEye cloud service. Once the equipment is connected to the internet and added into WeldEye, the equipment logs in to WeldEye automatically. For more information on using the WeldEye cloud service, refer to the WeldEye documentation in your organization's WeldEye cloud service.

-  *The selections in the WeldEye view are made beforehand for the weld or work in question. The weld data is then saved along with these selections in the WeldEye cloud service after the work has been completed.*
-  *If the welding equipment loses the internet connection during work, the weld data is saved locally and synchronized with the WeldEye cloud service once the connection has been restored.*
-  *WeldEye is a highly configurable welding management software. Depending on your WeldEye cloud service settings, some of the attributes or features mentioned here may be disabled or not used in your organization. Refer to your WeldEye administrator for more information.*

Selecting welder

The **WeldEye view** allows selecting the welder for the welding work at hand. The welders are predefined in the WeldEye cloud service.

1. Go to the WeldEye view and select "Welder" by turning and pressing the right control knob.

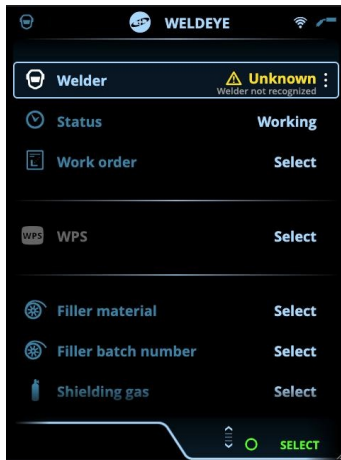

2. Select your name on the list.

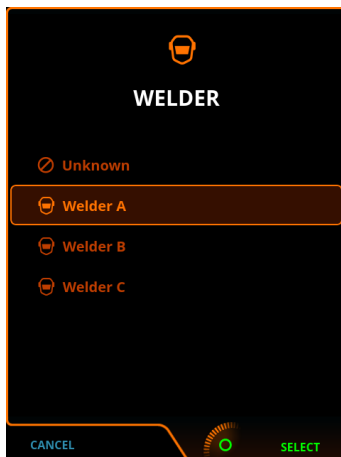

If your name is not on the list, you can leave the welder unselected (unknown).

Selecting status

The welder's status can also be reported in the WeldEye view. This is used primarily for reporting when the actual welding work has been interrupted temporarily, typically due to maintenance or some other reason. The status options (reason codes) are specified in the WeldEye cloud service.

By default, the status is not defined, which is indicated by the text "Undefined".

1. In the WeldEye view, select "Status" by turning and pressing the right control knob.
2. Select the status from the menu.

When the welding commences, the status is automatically reset to undefined.

Selecting work order and weld

In the WeldEye view you can select digital work orders assigned to you in the Kemppi WeldEye cloud service. The work order feature is enabled by default.



In case the use of work orders has been disabled in the WeldEye settings, welds are selected directly from a list (categorized by projects and/or weld lists), and welder-specific weld filtering is not applied.

1. In the WeldEye view, select "Work order" by turning and pressing the right control knob.
2. Select a work order from the list.

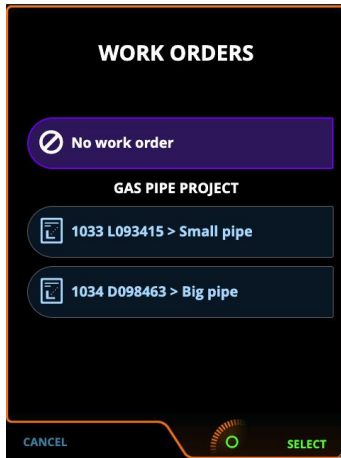

3. If the work order has more than one weld or weld pass included, select also the specific weld or weld pass to be welded.

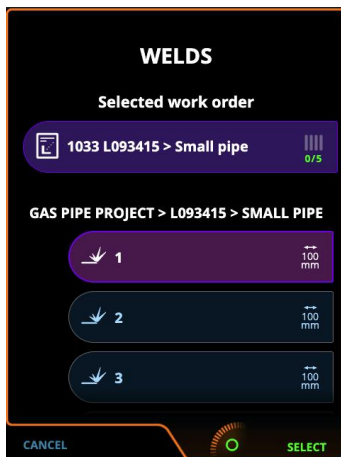

The welds and weld passes on the work order can have digital WPSes (welding procedure specifications) attached to them. When a work order is selected, and it has a WPS or WPSes included, a WPS row is shown in the WeldEye view.

-  *A digital WPS may contain one or more requirements or recommendations for the welder's qualification and the filler material and gas to be used. If the welder or the materials selected do not meet the criteria on the work order, it is indicated with a caution symbol.*

Applying digital WPS

If the selected weld on the work order includes a digital WPS that has already been linked to a memory channel, that memory channel is automatically activated. For more information on digital WPSes on the Master M 358 equipment, refer to "Control panel: WPS view" on page 44.

If no WPS is selected, you can go to the WPS row in the WeldEye view, and select an available WPS.

Also WPS linking or re-linking can be accomplished directly from the WeldEye view. To link or re-link WPS:

1. In the WeldEye view, select the weld and weld pass below the WPS row by turning and pressing the right control knob.



2. In the menu that opens, select the weld pass and WPS linking you want to edit.

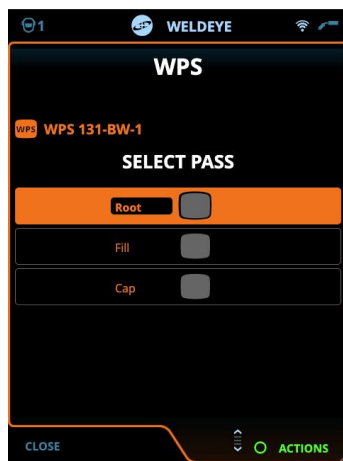

3. Open the actions menu and select "Link to channel".

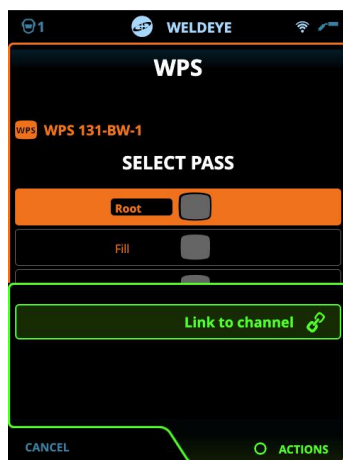

4. In the memory channel list, select the memory channel you want to link the WPS with.
>> If needed, select "Filter channel list" to filter memory channels based on the WPS specifications.

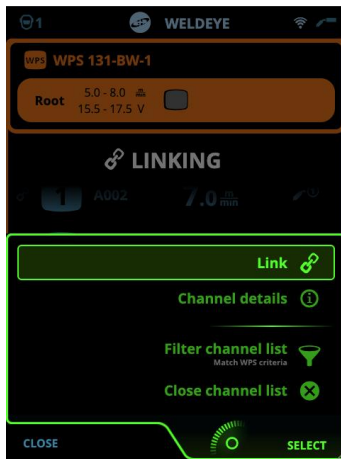



You can access the weld pass selection of the active WPS by selecting the weld pass row in the WeldEye view. In the selection dialog that opens, all of the weld passes are listed and each of them can be linked to a memory channel.

When a WPS is linked to a memory channel, that channel is automatically applied.

Entering material information

The lower section of the WeldEye view shows the filler wire material and gas information including their batch identification (if and as required).

-  *The material information filled in the WeldEye view should always match with the filler material and gas used in welding (i.e., what is installed in the welding equipment).*
-  *A digital WPS may include several recommendations for filler material and gases. You can check and change the recommended materials in the WeldEye view.*
-  *A digital WPS may contain one or more requirements or recommendations for the welder's qualification and/or the filler material and gas to be used. If the welder or the materials selected do not meet the criteria, it is indicated with a caution symbol.*

1. Select the filler material and gas in the corresponding menus by turning and pressing the right control knob.

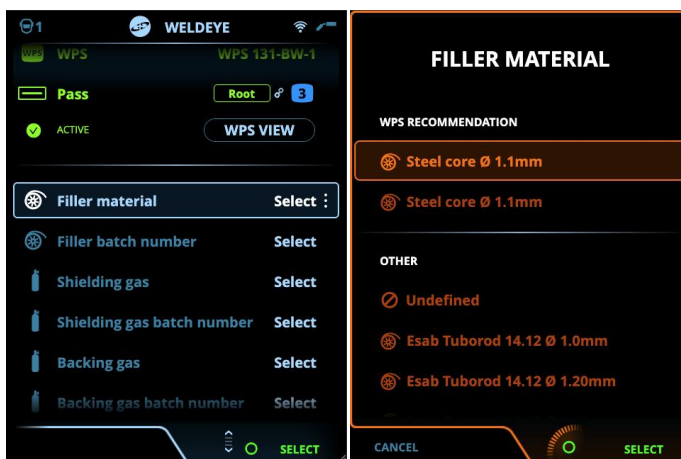

2. Select or enter also the batch information if/as required with the right control knob.
 - >> A virtual keyboard is used for entering the filler or gas batch identification manually, if the correct batch identification is not already on the list. Once the batch identification information has been entered for the first time, it becomes available as a pre-filled list option for later use.

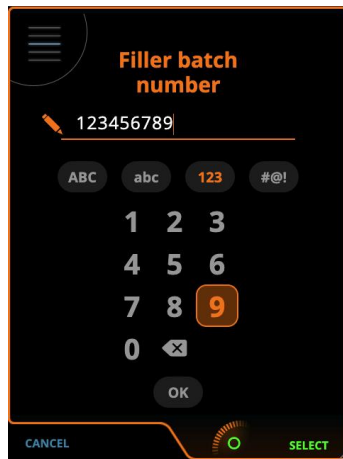

3. Ensure that the selected filler material and gas are installed and ready for welding.

Selecting work piece

Also the work piece information can be used and saved in WeldEye. If this feature is enabled in the WeldEye cloud service settings, the work piece selection is available in the WeldEye view.

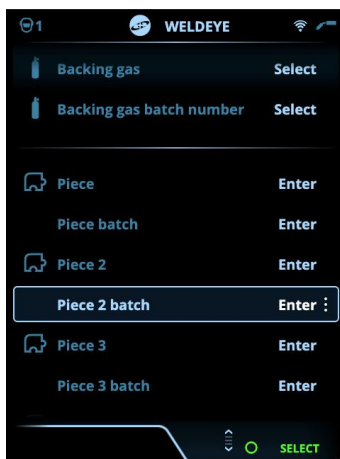

1. Select the work piece by turning and pressing the right control knob.
2. Enter the work piece information using the virtual keyboard with the right control knob.

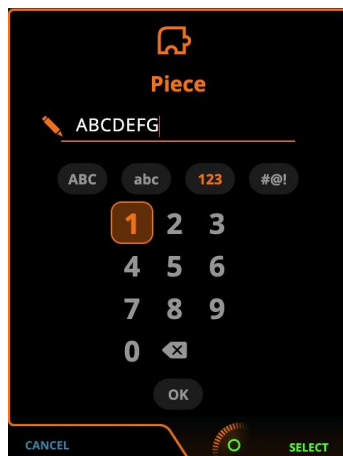

Completing work

Once work (work order, weld, weld pass) has been completed, it can be confirmed in the weld status view that opens right after finishing a weld. This view also replaces the standard weld data view in WeldEye use.

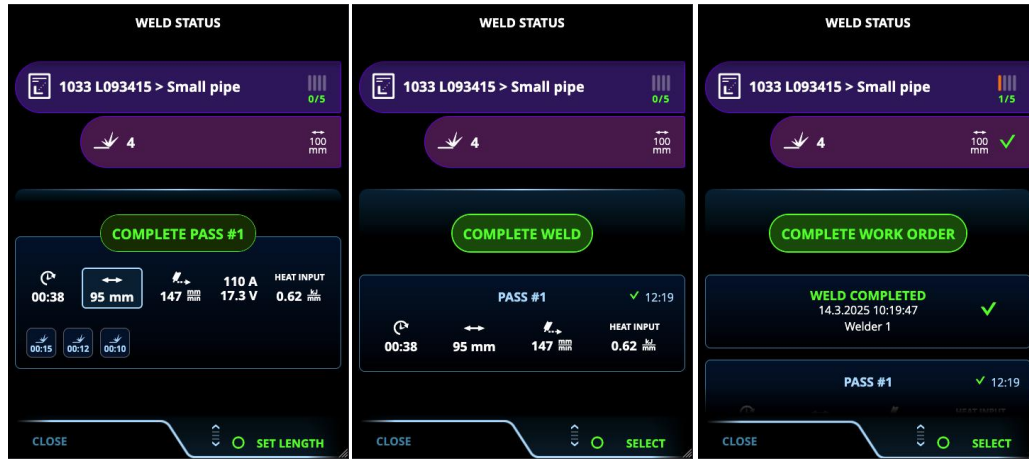

If the work has not been marked as completed right after finishing the weld, it can be done also in the WeldEye view:

1. Go to the work you finished, and select "Weld status" by turning and pressing the right control knob.
2. In the weld status dialog, select "Complete pass", "Complete weld" or "Complete work order", depending on which work stage you're finishing.



When completing a weld pass, the weld length can be entered in the weld status view by selecting the length symbol and "Set length" with the right control knob button.



-  Even if all of the individual welds are marked as completed, the work order itself must also be completed in the WeldEye view.
-  It is possible to mark welds and work orders completed even if they would contain incomplete weld passes and/or welds. Make sure that all of the welding work has been completed as required before completing welds or work orders in WeldEye.

More related feature descriptions here:

- >> "WeldEye" on page 76
- >> "Digital Welding Procedure Specification (dWPS)" on page 75
- >> "WeldEye ArcVision" on page 76

>> "WeldEye with DCM" on page 77

3.3.6 CONTROL PANEL: WELDING PARAMETERS

The Welding parameters view includes a start and stop curve for adjusting the most essential parameters for a weld. The bottom section of the view lists the available adjustments for the selected welding process. The welding process selection is based on the active memory channel and its settings.

 *Many of the welding parameters are welding process specific and are visible and available for adjustment accordingly.*

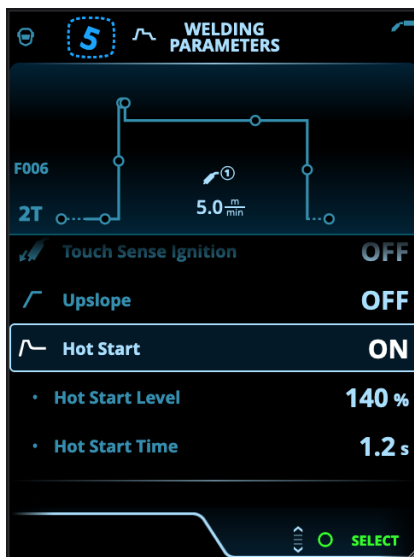

Adjusting welding parameters

1. Turn the right control knob to highlight the desired welding parameter.
2. Press the right control knob to select the welding parameter for adjustment.
3. Turn the right control knob to adjust welding parameter value.
 - >> Depending on the parameter to be adjusted, refer also to the Welding parameters table below for more details.
4. Confirm the new value / selection and close the adjustment view by pressing the right control knob.

Saving welding parameters for later use

A work channel is automatically created for the changed welding parameters. To save the set welding parameters on a memory channel, do one of the following:

- **Quick active channel option:** Keep the Channels shortcut button pressed for approximately 2 seconds.
 - >> This will save the parameter settings onto the currently active channel replacing its previous parameter settings.
- **Channels view option:** Go to the Channels view and save the parameter settings onto a new channel.
 - >> Refer to "Control panel: Channels" on page 42 for more information.

Welding parameters and feature descriptions

MIG and 1-MIG welding parameters

The parameters listed here are available for adjustment with the MIG and 1-MIG processes.

Parameter	Parameter value	Description
Process	MIG, 1-MIG, Pulse, DPulse, MAX Cool, MAX Speed, MAX Position	This MIG welding process selection depends on the active welding program. For more information on the additional processes, refer to "Additional guidance to functions and features" on page 69.
Trigger logic	2T, 4T	Welding guns can have several alternative trigger operation modes (trigger logics). Most common are 2T and 4T. In 2T mode you hold the trigger down while welding. In 4T mode you press and release the trigger to start or to stop welding. For more information, refer to "Trigger logic functions" on page 69.
Cycle timer	ON/OFF Default = OFF	Cycle timer is a welding function that automatically produces a weld or welds of predefined duration. For more information, refer to "Cycle timer" on page 80.
- Cycle arc time	0.0 ... 60.0 s Default = 2.0 s	
- Cycle pause	ON/OFF Default = OFF	
- Cycle pause time	0.1 ... 3.0 s, step 0.1 s Default = 0.1 s	
Pre gas	0.0 ... 9.9 s, Auto, step 0.1 0.0 = OFF	Welding function that starts the shielding gas flow before the arc ignites. This ensures that the metal does not come into contact with air at the start of the weld. Time value is preset by the user. Used for all metals, but especially for stainless steel, aluminum and titanium.
Creep start	10...90 %, Auto, step 1	The Creep start function defines the wire feed speed before the welding arc ignites, that is, before the filler wire comes in contact with the workpiece. When the arc ignites, the wire feed speed is automatically switched to the normal user-set speed. The Creep start function is always on.
Touch Sense Ignition	AUTO/ON/OFF	Touch Sense Ignition (TSI) delivers minimum spatter and stabilizes the arc immediately after ignition.

Wire feed speed	0.50 ... 25 m/min, step 0.05 or 0.1 Default = 5.00 m/min	Wire feed speed adjustment. When the wire feed speed is less than 5 m/min, the adjustment step is 0.05 and when the wire feed speed is 5 m/min or more, the adjustment step is 0.1.
Wire feed speed min	Min/Max = 0.5 ... 25 m/min, step 0.1 Default = 0.5 m/min	Minimum and maximum limits for the wire feed speed adjustment.
Wire feed speed max	Min/Max = 0.5 ... 25 m/min, step 0.1 Default = 25 m/min	
Voltage	Min/Max = According to welding equipment specifications, step 0.1	Welding voltage adjustment and the minimum and maximum limits for the welding voltage adjustment. These parameters are available for adjustment in MIG only. In 1-MIG the voltage is defined by welding program.
Dynamics	-10.0 ... +10.0, step 0.2 Default = 0	Controls the short circuit behavior of the arc. The lower the value the softer the arc, the higher the value the rougher the arc. (Not available with MAX Cool and MAX Speed.)
Crater fill	ON/OFF	When welding with high power, a crater is usually formed at the end of the weld. The Crater fill function decreases the welding power / wire feed speed at the end of the welding job so that the crater can be filled using a lower power level. With MIG process, Crater fill duration, wire feed speed and voltage are preset by the user. When the wire feed speed is less than 5 m/min, the adjustment step is 0.05 and when the wire feed speed is 5 m/min or more, the adjustment step is 0.1. For 1-MIG process, refer to the 1-MIG parameter table.
- Crater fill time	0.1 ... 10.0 s, Auto, step 0.1 Default = 1.0 s	
- Crater fill wire feed speed	0.70 ... 25.0 m/min, Auto, step 0.05 or 0.1 Default = 5 m/min	
- Crater fill voltage	8 ... 45 V, Auto, step 0.1 V Default = 18V	
Post current	-30 ... +30	
Wire feed end step (WF end step)	OFF/ON Default = OFF	Wire feed end step feature prevents the filler wire from sticking to the contact tip when the welding ends.

Post gas

0.0 ... 9.9 s, Auto, step 0.1
0.0 = OFF

Welding function that continues the shielding gas flow after the arc has extinguished. This ensures that the hot weld does not come into contact with air after the arc is extinguished, protecting the weld and also the electrode. Used for all metals. Especially stainless steel and titanium require longer post gas times.

1-MIG welding parameters

The parameters listed here are available for adjustment only with the 1-MIG process.

Parameter	Parameter value	Description
Trigger logic	2T, 4T, Powerlog (2 levels or 3 levels)	Welding guns can have several alternative trigger operation modes (trigger logics). Most common are 2T and 4T. In 2T mode you hold the trigger down while welding. In 4T mode you press and release the trigger to start or to stop welding. Note that enabling Powerlog opens additional Powerlog settings in the Welding parameters view. For more information, refer to "Trigger logic functions" on page 69.
Upslope	ON/OFF	Upslope is a welding function that determines the time, during which the welding current gradually increases to the desired welding current level at the start of the weld. The upslope start level and time are preset by the user.
- Upslope start level	10 ... 100 %, Auto, step 1 Default = 50	
- Upslope time	0.1 ... 5 s, Auto, step 0.1 Default = 0.10	
Hot start	ON/OFF	Welding function that uses higher or lower wire feed speed and welding current at the start of the weld. After the Hot start period the current changes to normal welding current level. This facilitates the start of the weld especially with aluminum materials. The Hot start slope time adjustment sets the transition time from the Hot start phase to the normal welding current level. The Hot start level and time are adjustable in 2T trigger logic only. Hot start fine tuning (voltage) is adjustable with 1-MIG, Pulse, DPulse and MAX Speed processes, when a Wise feature is not in use.
- Hot start level	-50 ... +200 %, Auto, step 1 Default = 40	
- Hot start fine tuning	-10.0 ... +10.0, step 0.1 Default = 0.0	
- Hot start time	0.0 ... 9.9 s, Auto, step 0.1 Default = 1.2 s	
- Hot start slope time	0.0 ... 10.0 s, step 0.1 s Default = 1.0 s	
Wise feature	None, WiseFusion, WisePenetration, WiseSteel	When selected, a list of available Wise features is opened for selection. For more information on these features, refer to "Additional guidance to functions and features" on page 69. (Not available with MAX Cool, MAX Speed and MAX Position.)
Fine tuning	Example: -10.0 ... +10.0 V * Step 0.1 V	Fine tuning of the welding voltage. * The voltage range for fine tuning is defined by the active welding program.

Crater fill	ON/OFF	When welding with high power, a crater is usually formed at the end of the weld. The Crater fill function decreases the welding power / wire feed speed at the end of the welding job so that the crater can be filled using a lower power level. Crater fill fine tuning (voltage) is adjustable with 1-MIG, Pulse, DPulse and MAX Speed processes, when a Wise feature is not in use.
- Crater fill start level	10 ... 150 %, Auto, step 1 Default = 100	
- Crater fill time	0.0 ... 10.0 s, Auto, step 0.1 Default = 1.0 s	
- Crater fill end level	10 ... 150 %, Auto, step 1 Default = 30	
- Crater fill fine tuning	-10.0 ... +10.0, step 0.1 Default = 0.0	
Current	15 ... 350 A, step 1 Default = 50 A	Welding current adjustment with WisePenetration only.

Pulse/DPulse welding parameters

The parameters listed here are available for adjustment in addition to the MIG and 1-MIG welding parameters.

Parameter	Parameter value	Description
Pulse current %	-10 ... +15 %, step 1	The pulse current fine tuning relative to the current with Pulse and DPulse welding processes.
DPulse ratio	10 ... 90 %, step 1	This adjusts the double pulse time percentage, i.e. how long the double pulse is at the first pulse level. The second pulse level is determined in relation to the first level setting.
DPulse frequency	0.4 ... 8.0 Hz, Auto, step 0.1	This adjusts the double pulse frequency. How long it takes from the start of 1st level to the end of 2nd level.
DPulse level 1: Wire feed speed	0.50 ... 25 m/min, step 0.05 or 0.1	First double pulse level wire feed speed (and minimum / maximum values for wire feed speed). When the wire feed speed is less than 5 m/min, the adjustment step is 0.05 and when the wire feed speed is 5 m/min or more, the adjustment step is 0.1.
DPulse level 1: Fine tuning	-10 ... +10, step 1	Fine tuning of the welding voltage.
DPulse level 1: Dynamics	-10.0 ... +10.0, step 0.2 Default = 0	Controls the short circuit behavior of the arc. The lower the value the softer the arc, the higher the value the rougher the arc.

DPulse level 2: Wire feed speed	0.50 ... 25 m/min, step 0.05 or 0.1	Second double pulse level wire feed speed. The DPulse level 2 wire feed speed changes automatically when the DPulse level 1 wire feed speed setting is adjusted. When the wire feed speed is less than 5 m/min, the adjustment step is 0.05 and when the wire feed speed is 5 m/min or more, the adjustment step is 0.1.
DPulse level 2: Fine tuning	-10 ... +10, step 1	Fine tuning of the welding voltage.
DPulse level 2: Dynamics	-10.0 ... +10.0, step 0.2 Default = 0	Controls the short circuit behavior of the arc. The lower the value the softer the arc, the higher the value the rougher the arc.

MAX Speed parameters

The parameters listed here are MAX Speed process specific.

Parameter	Parameter value	Description
MAX Speed frequency	100 ... 800 Hz, Auto step 10	MAX Speed frequency setting.

MAX Position parameters

The parameters listed here are MAX Position process specific.

Parameter	Parameter value	Description
MAX Position frequency	-0.5 ... +0.5 Hz, step 0.1 Default = 0	MAX Position frequency fine tuning.
Pulse current %	-10 ... 15 %, step 1 Default = 0	MAX Position pulse current adjustment.
Plate thickness	3.0 ... 12.0 mm	MAX Position plate thickness setting.

TIG welding parameters

The parameters listed here are available for adjustment with the TIG process.

Parameter	Parameter value	Description
Trigger logic	2T, 4T	Welding guns can have several alternative trigger operation modes (trigger logics). Most common are 2T and 4T. In 2T mode you hold the trigger down while welding. In 4T mode you press and release the trigger to start or to stop welding.
Post gas	0.0 ... 9.9 s, step 0.1 0.0 = OFF	Welding function that continues the shielding gas flow after the arc has extinguished. This ensures that the hot weld does not come into contact with air after the arc is extinguished, protecting the weld and also the electrode. Used for all metals. Especially stainless steel and titanium require longer post gas times.
Current	15 ... 350 A, step 1 Default = 50 A	Welding current adjustment.

MMA welding parameters

The parameters listed here are available for adjustment with the MMA process.

Parameter	Parameter value	Description
Dynamics	-10.0 ... +10.0, step 0.2 Default = 0	Controls the short circuit behavior of the arc. The lower the value the softer the arc, the higher the value the rougher the arc.
Hot start level	-30 ... +30 Default = 0	Welding function that uses higher or lower welding current at the start of the weld. After the Hot start period the current changes to normal welding current level. This facilitates the start of the weld especially with aluminum materials. In MMA the Hot start level is preset by the user.

Current	15 ...350 A, step 1 Default = 50 A	Welding current adjustment.
Current limit min	Min/Max = 15...350 A, step 1 Default = 50 A	Minimum and maximum limits for the current adjustment.
Current limit max	Min/Max = 15...350 A, step 1 Default = 50 A	

3.3.7 CONTROL PANEL: WELD HISTORY

The Weld history view collects the information of the past welds (the last 10) into one view for later checking. To change how the weld data averages are calculated (with or without slope phases) refer to "Control panel: Device settings" on the next page.

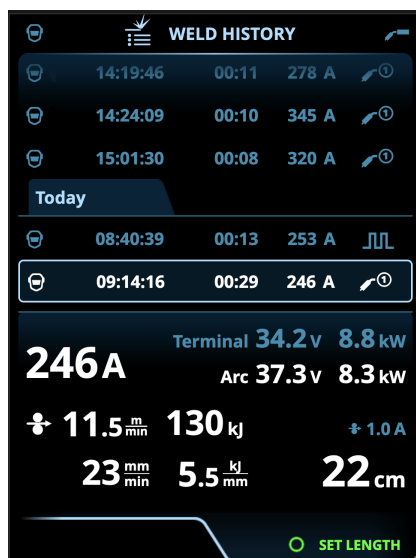

Heat input calculation in weld history view

The heat input of a weld can be calculated by entering the weld length into the weld's history entry.

1. Select 'Set length' by pressing the right control knob button.
2. Set the weld length by turning the right control knob.
3. Confirm the weld length for calculation by pressing the control knob button.

3.3.8 CONTROL PANEL: INFO VIEW

The **Info** view shows information on the device usage.

Through this view it is also possible to access the error logs, list of installed welding programs, additional operating information and device info, such as the software version and equipment serial numbers.

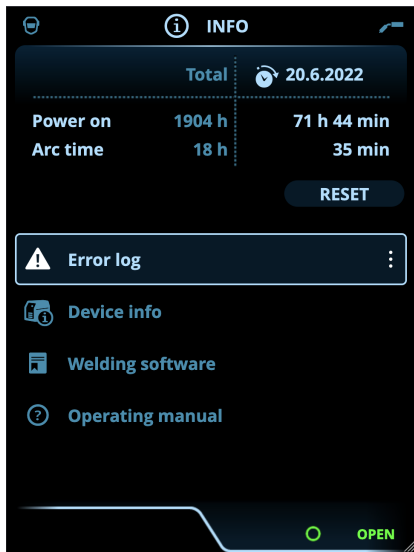

3.3.9 CONTROL PANEL: DEVICE SETTINGS

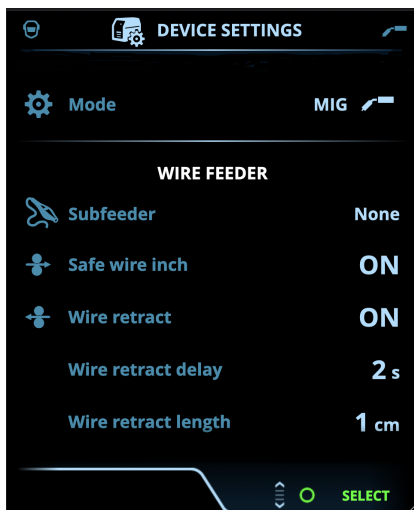

Changing settings

1. Turn the right control knob to highlight the desired settings parameter.
2. Press the right control knob to select the settings parameter for adjustment.
3. Turn the right control knob to select the settings value.
 - >> Depending on the settings parameter to be adjusted, refer also to the Settings table below for more details.
4. Confirm the new value / selection and close the adjustment view by pressing the right control knob.

Settings

Parameter	Parameter value	Description
-----------	-----------------	-------------

Mode	MIG/TIG/MMA	Note: For TIG welding the polarity (+/-) must also be switched. For more information, refer to "Changing welding polarity" on page 85.
Demo time	OFF/ON	The demo time feature allows you to try out optional welding features and functions without a license for a limited time. The total available demo time is 3 hours. The demo time passes only when welding using a welding feature you don't have a license for. When the demo time is set to ON, the remaining time is shown on the display.
Settings lock	Not in use / Unlocked / Locked	Settings lock is used to restrict changes to a predefined set of welding parameters and device settings. When this feature is turned on, the settings can be locked and unlocked in the device settings. A PIN code can be set for the settings lock. For more information, refer to "Settings lock" on page 81.
Remote control	OFF / Hand remote / Torch remote Default = OFF	If remote controller is not connected, this selection is not available. Note: This setting does not affect and is not affected by the HR55 remote control.
Remote mode (with 1-knob remote control)	<i>Wire feed speed or current</i> / Channel	This determines what is changed with the remote, welding parameter or memory channel (available channels: 1...5). The parameters are process-specific. If remote controller is not connected and remote not selected, this selection is not available.
Remote mode (with 2-knob remote control)	<i>Welding parameters</i> / Channel	Note (2-knob remote): When the remote mode is set to 'Channel', only the left remote control knob is in use. Note: If the HR55 remote control is also connected, the parameter that is selected here cannot be adjusted with the HR55 remote control.

Subfeeder (with MIG only)	<i>Subfeeder model</i> / None Default = None	If a compatible subfeeder is connected, select the subfeeder from the list. Compatible subfeeders: <i>SuperSnake GTX (10 m, 15 m, 20 m, 25 m), Binzel PP401D, Binzel PP36D.</i>
Safe wire inch (with MIG only)	OFF/ON	When ON, and the arc doesn't ignite, the filler wire is fed 5 cm When OFF, 5 m of filler wire is fed.
Wire retract	OFF/ON	This is an automatic wire retract feature. Once the arc is extinguished, the wire is retracted for additional safety. The user can change the wire retract delay and length settings. Note: Wire retract function is disabled if a subfeeder is connected.
- Wire retract delay	2...10 s, step 1 Default = 5 s	
- Wire retract length	1...10 cm, step 1 Default = 2 cm	
Gas guard	OFF/ON Default = OFF	Gas guard prevents welding without shielding gas.
Language	Available languages	This allows the user to select the control panel language from a list of available languages.
Weld data time	0...30 s, step 1 0 = OFF Default = 5 s	This defines if and how long the weld data summary is shown after each weld.
Weld data average	Without slopes / Entire weld Default = Without slopes	This feature allows the user to change how the weld data averages are calculated: with or without the slope phases in the beginning and in the end of the weld. This setting affects the calculation of the averages for the following: welding voltage (terminal and arc voltage), welding current, welding power and wire feed speed.
Brightness	1...10	The control panel display brightness.
Date	Current date	Date setting.
Time (24h)	Current time	Time setting in 24h format.
Screensaver	OFF/1...120 min, step 1 Default = 5 min	The screensaver image is shown on display after the set time period. By default, the Kemppi logo is shown. To change the screensaver image, refer to "USB update" on page 79.

Cable calibration (with MIG only)	Start/Cancel	The date and time and the calibration information of the previous calibration is also shown. Refer to "Calibrating welding cable" on page 37 for cable calibration.
Water cooling	OFF/Auto/ON Default = Auto	When ON is selected, the coolant is circulated continuously, and when Auto is selected, the coolant is circulated only during welding.
VRD (with MMA only)	Always ON (with MMA only)	Voltage reduction device (VRD) reduces the open-circuit voltage to maintain below a certain voltage value.
Backup	(Selection)	This allows the settings to be saved on a connected USB memory stick.
Restore	(Selection)	This allows the settings to be restored from a connected USB memory stick.
Factory reset	Reset/Cancel Default = Cancel	This resets the machine to factory settings.

3.3.10 CONTROL PANEL: APPLYING WELDING PROGRAMS

To select and apply a MIG welding process and program, a corresponding memory channel must be created.

When creating the memory channel for a particular MIG welding process, the selection of welding programs can be narrowed down based on the available MIG welding processes: Manual, 1-MIG, MAX Speed (optional), MAX Position (optional) and MAX Cool (optional).

Use the welding program that is in accordance with your welding setup (e.g. welding wire and gas properties).

1. Go to the Memory channels view. (Refer to "Control panel: Channels" on page 42 for more information.)
2. Enter the actions menu.
3. Select **Create channel**.
 - >> A filter view opens.

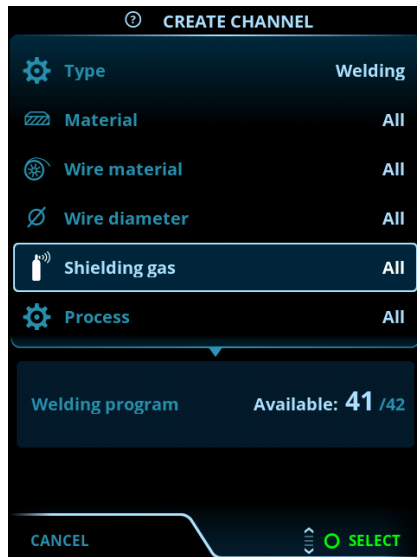

4. Use the filter options (e.g. material, wire material or wire diameter) to find the welding programs best suited for the purpose.
- i** The operation mode set in the panel [Settings](#) determines for which main welding process the programs here are shown. In MIG mode, the process selection in the Create channel view allows to narrow down the search more specifically to different MIG processes.*
- i** If manual MIG is selected as the process, other filter and welding program selections are disabled.*
5. Once ready, go to the **Welding program** selection at the bottom to view the suitable welding programs.



6. Select a welding program.
- >> The selected welding program is now shown in the filter view.

7. To save, scroll down to **Save to** and select it.

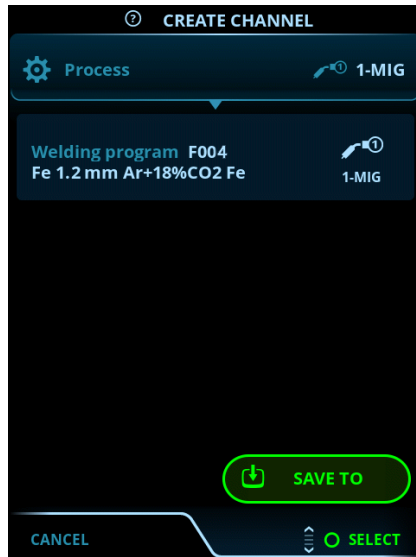

Select the memory channel slot for saving and confirm.

Once ready, you can continue to the Welding parameters view to adjust the welding settings for the new channel, create a new channel or go back to the Channels view.

Tip: It is also possible to create new channels based on all of the unused welding programs available for the selected operation mode by selecting **Create all** in the Channel view's actions menu. This option uses the available memory channel slots.

3.3.11 CONTROL PANEL: WELD DATA VIEW

After each weld, a weld summary is displayed briefly. To change the weld data view duration or how the weld data averages are calculated (with or without slope phases), refer to "Control panel: Device settings" on page 63.

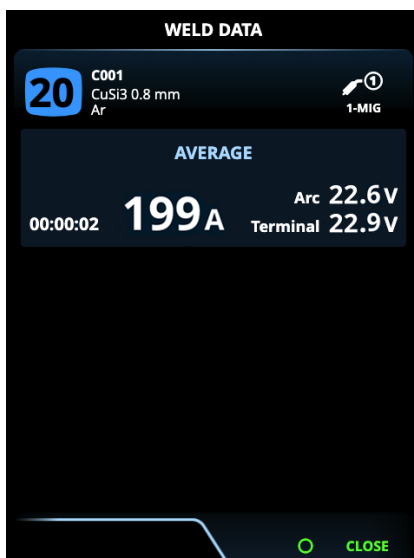

3.4 ADDITIONAL GUIDANCE TO FUNCTIONS AND FEATURES

This section summarizes the Master M 358 functions and features and how to use them.

3.4.1 TRIGGER LOGIC FUNCTIONS

You can select the trigger logic in the [Welding parameters view](#).

2T

In 2T, pressing the trigger ignites the arc. Releasing the trigger switches the arc off.



4T

In 4T, pressing the trigger starts the pre gas, and releasing the trigger ignites the arc. Pressing the trigger again switches the arc off. Releasing the trigger ends the post gas.



Powerlog

Powerlog trigger logic function allows the user to switch between two or three different power levels. In Powerlog, pressing the trigger starts the pre gas, and releasing the trigger ignites the arc. A quick press of the trigger during welding switches between levels (after the last defined power level the first level is selected). Long-pressing the trigger at any of the levels during welding switches the arc off.

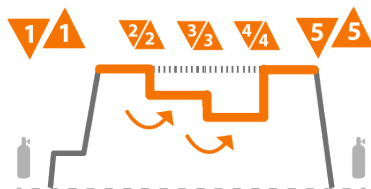



To take Powerlog into use, go to the control panel's [Welding parameters view](#) and select Powerlog as the trigger logic. Once selected, choose whether 2 or 3 power levels are used. Still in the Welding parameters view, set up the power levels for this function. The parameters available for adjustment for each level are:

- Wire feed speed and its minimum and maximum values
- Voltage / Fine tuning
- Dynamics (not available with MAX Cool).

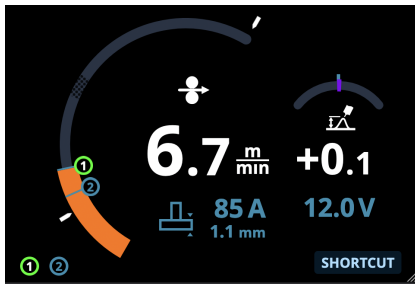
The wire feed speed of each level can also be adjusted in the Home view. Pressing the left control knob button changes between levels. Green color indicates the selected Powerlog level:



-  *Powerlog trigger logic is not available together with WiseSteel feature or with manual MIG, MAX Speed, MAX Position or DPulse processes.*
-  *Powerlog trigger logic cannot be used together with a remote control. If a Powerlog memory channel is selected when a remote control is in use, the trigger logic is automatically switched to 4T.*

3.4.2 1-MIG

1-MIG is a MIG/MAG welding process where the voltage is defined automatically when you adjust the wire feed speed. The voltage is calculated based on the welding program in use. The process is suitable for all materials, shielding gases and welding positions. 1-MIG supports WiseSteel, WisePenetration and WiseFusion features, as well as various optimized welding programs.

- >> To take 1-MIG into use, go to the [Memory channels view](#) and select an existing memory channel with 1-MIG process.

If there aren't any 1-MIG memory channels available, create a new one for 1-MIG process by selecting an available 1-MIG welding program for the channel. Follow the instructions in "Control panel: Applying welding programs" on page 66.

3.4.3 WISEFUSION FEATURE



The WiseFusion welding feature enables adaptive arc length control, which keeps the arc optimally short and focused. WiseFusion increases the welding speed and penetration and decreases heat input. WiseFusion can be used throughout the power range (short arc, globular arc and spray arc). WiseFusion is compatible with 1-MIG and pulsed MIG welding processes. (Not available with MAX Cool, MAX Speed and MAX Position.)

- >> To take WiseFusion into use, go to the control panel's [Welding parameters view](#) and apply the WiseFusion feature.
- >> To adjust the welding power/wire feed speed, in the control panel's [Home view](#), turn the left control knob.
- >> To fine tune the heat output while welding, in the control panel's [Home view](#), turn the right control knob.

For more information on Wise products, visit www.kemppi.com.

3.4.4 WISEPENETRATION FEATURE



In standard MIG/MAG welding, changes in stick-out length cause welding current to fluctuate. WisePenetration maintains constant welding current by controlling the wire feed speed according to the stick-out length. This ensures stable and effective penetration and prevents burn through. WisePenetration also adjusts the voltage adaptively, which keeps the arc focused and optimally short. WisePenetration enables welding with Reduced Gap Technology (RGT) and is compatible with 1-MIG welding process. (Not available with MAX Cool, MAX Speed and MAX Position.)

- >> To take WisePenetration into use, go to the control panel's [Welding parameters view](#) and apply the WisePenetration feature.
- >> To adjust the welding current while welding, in the control panel's [Home view](#), turn the left control knob.
- >> To fine tune the heat output while welding, in the control panel's [Home view](#), turn the right control knob.

For more information on Wise products, visit www.kemppi.com.

3.4.5 WISESTEEL FEATURE



The WiseSteel welding feature is based on modifying the conventional MIG/MAG arcs to enable higher quality of welds. WiseSteel improves the arc control, reduces spatter and helps create an optimally-formed weld pool. WiseSteel feature is available with selected welding programs. (Not available with MAX Cool, MAX Speed and MAX Position.)

- >> To take WiseSteel into use, go to the control panel's [Welding parameters view](#) and apply the WiseSteel feature.
- >> To adjust the welding power/wire feed speed while welding, in the control panel's [Home view](#), turn the left control knob.
- >> To fine-tune the heat output while welding, in the control panel's [Home view](#), turn the right control knob.

When using WiseSteel, different adjustment methods are applied at different power ranges (different arcs). The wire feed speed / current indicator shows the arc range: Short arc — Globular arc — Spray arc.

Short arc range:

- WiseSteel is based on adaptive short arc control; that is, the process adjusts the short circuit ratio. This creates an easily-adjustable arc and less spatter. Within the short arc range, the shape of the current is similar to the traditional short arc welding. When a short arc is used in vertical up welding where weaving motion is applied, WiseSteel ensures good quality through adapting to the changes in the stick-out length.

Globular arc range:

- Globular arc means that WiseSteel fluctuates the power between short arc and spray arc at a low frequency, so that the average power stays within the globular arc range. This results in less spatter than conventional globular arc welding, and a welding pool that enables excellent structural durability.

Spray arc range:

- Within the spray arc range, WiseSteel is based on adaptive arc length control, which keeps the arc optimally short. WiseSteel also utilizes micro-pulsed welding current. This creates a well-formed weld pool that enables excellent bead geometry and optimal penetration with smooth and durable joints, and

speeds up the work. The pulsing is not noticeable to the welder. The shape and control of the current are close to the conventional spray arc welding.

For more information on Wise products, visit www.kemppi.com.

3.4.6 PULSE WELDING

The advantages of Pulse are a higher welding speed and deposition rate compared to short-arc welding, lower heat input compared to spray-arc welding, a spatter-free globular arc and smooth appearance of the weld. Pulse is suitable for all position welding. It is excellent for welding aluminum and stainless steel, especially when the material thickness is small.

Pulse



Pulse is a synergic MIG/MAG welding process where the current is pulsed between the base current and the pulse current.

- >> To take Pulse welding process into use, go to "Control panel: Channels" on page 42 and select an available Pulse channel.

If there aren't any Pulse memory channels available, create a new one for Pulse process by selecting an available Pulse welding program for the channel. Follow the instructions in "Control panel: Applying welding programs" on page 66.

- >> Once selected, the corresponding Pulse welding process parameters become available for adjustment in the **Welding parameters** view. For more information, refer to the pulse welding parameters in "Control panel: Welding parameters" on page 54.

DPulse



DPulse is a double-pulse MIG/MAG welding process with two separate power levels. The welding power varies between these two levels. The parameters of each level are controlled independently.

- >> To take DPulse welding process into use, go to "Control panel: Channels" on page 42 and select an available Pulse channel.

If there aren't any Pulse memory channels available, create a new one for Pulse process by selecting an available Pulse welding program for the channel. Follow the instructions in "Control panel: Applying welding programs" on page 66.

- >> Once selected, the corresponding DPulse welding process parameters become available for adjustment in the **Welding parameters** view. For more information, refer to the pulse welding parameters in "Control panel: Welding parameters" on page 54.

3.4.7 MAX COOL PROCESS

MAX Cool is a synergic MIG/MAG welding process that is designed for root pass welds and sheet metal applications. MAX Cool is suitable for all welding positions and provides a smooth arc, reducing spatter.

- >> To take MAX Cool into use, go to the control panel's [Welding parameters view](#) and apply MAX Cool. Optionally, go to the [Memory channels view](#) and create a new memory channel with MAX Cool process.

- >> To adjust the wire feed speed while welding, or in the control panel's [Home view](#), turn the left control knob. The adjustment's effect on the plate thickness is also shown.
- >> To fine tune the heat output while welding, or in the control panel's [Home view](#), turn the right control knob.

Max Cool supports these filler wire and shielding gas combinations:

- Fe solid & Ar + 8...25 % CO₂ (1.0 mm, 1.2 mm)
- Fe solid & CO₂ (1.0 mm, 1.2 mm)
- Ss solid & Ar + 2 % CO₂ (1.0 mm, 1.2 mm)
- CuSi3 & Ar (1.0 mm)
- CuAl8 & Ar (1.0 mm).

3.4.8 MAX POSITION PROCESS

MAX Position is a synergic MIG/MAG welding process optimized for vertical fillet welds (position: PF). MAX Position automatically switches between two separate power levels. The two power levels can use the same welding process or two different welding processes.

- >> To take MAX Position into use, go to the control panel's [Welding parameters view](#) and apply MAX Position. Optionally, go to the [Memory channels view](#) and create a new memory channel with MAX Position process.
- >> In [Welding parameters view](#), MAX Position frequency can be adjusted and the optional WiseFusion feature can be applied. The ratio of the two power levels is preset.
- >> To adjust the average wire feed speed while welding, or in the control panel's [Home view](#), turn the left control knob. The adjustment's effect on the plate thickness is also shown.
- >> To fine tune the welding voltage while welding, or in the control panel's [Home view](#), turn the right control knob.

MAX Position supports these filler wire and shielding gas combinations:

- Fe solid & Ar + 18% CO₂ (1.0 mm, 1.2 mm)
- Fe solid & Ar + 8% CO₂ (1.0 mm, 1.2 mm)
- Fe MC + 18% CO₂ (1.2 mm)
- Ss solid & Ar + 2% CO₂ (1.0 mm, 1.2 mm)
- AlMgI & Ar (1.0 mm, 1.2 mm)

MAX Position supports these plate thicknesses:

- 3...12 mm

MAX Position utilizes also other welding processes (depending on the material):

- Fe & Fe MC: 1-MIG (with low power) and Pulse MIG (with high power)
- Ss & Al: Pulse MIG (throughout the power range).

3.4.9 MAX SPEED PROCESS

MAX Speed is a synergic pulsed MIG/MAG welding process. It is designed to maximize the welding speed and to minimize the heat input by modifying the conventional MIG/MAG arcs. MAX Speed is designed for steel and stainless steel welding applications mainly in the PA and PB positions. It is suitable for plate thicknesses above 2.5 mm, the ideal maximum plate thickness being approximately 6 mm.

MAX Speed operates within the spray arc range. Welding current is pulsed with constant frequency and amplitude. Arc length is controlled with the normal voltage control. MAX Speed's low-amplitude pulsing enables an effective transfer mode with lower wire feed speed than with conventional MIG/MAG arc. The pulsing is not noticeable to the welder.

- >> To take MAX Speed into use, go to the control panel's [Welding parameters view](#) and apply MAX Speed. Optionally, go to the [Memory channels view](#) and create a new memory channel with MAX Speed process.
- >> In [Welding parameters view](#), the MAX Speed frequency can be adjusted.
- >> To adjust the wire feed speed while welding, or in the control panel's [Home view](#), turn the left control knob. The adjustment's effect on the plate thickness is also shown.
- >> To fine tune the welding voltage while welding, or in the control panel's [Home view](#), turn the right control knob.

MAX Speed supports these filler wire and shielding gas combinations:

- Fe solid & Ar + 18% CO₂ (1.0 mm, 1.2 mm)
- Fe solid & Ar + 8% CO₂ (1.0 mm, 1.2 mm)
- Fe MC & Ar + 18% CO₂ (1.2 mm)
- Ss solid & Ar + 2% CO₂ (1.0 mm, 1.2 mm).

3.4.10 WIRELESS CONNECTION (WLAN)

To connect the welding equipment to your local wireless network:

1. On the control panel, go to the **WLAN view**.
2. Turn the WLAN feature on by turning and pressing the right control knob.



3. Enter your local wireless network's SSID (Service Set Identifier), i.e. the name of your Wi-Fi network.

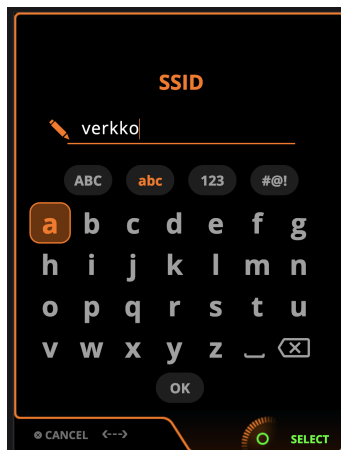

- >> Use the right control knob to select letters.

4. Enter your WLAN password.

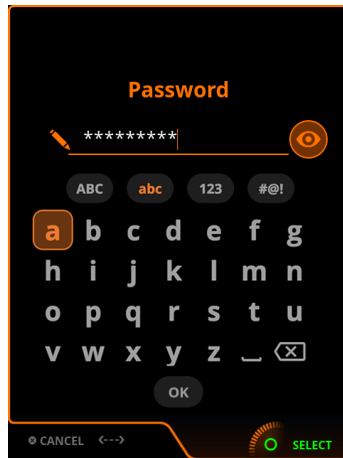

>> Use the right control knob to select letters.

Once connected, the WLAN status information is shown.

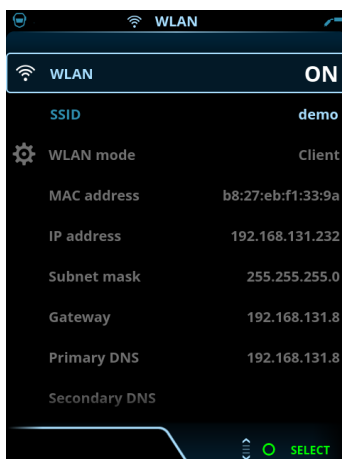

 The WLAN mode is set to 'Client' by default and it cannot be changed.

3.4.11 DIGITAL WELDING PROCEDURE SPECIFICATION (DWPS)

The use of digital WPS (Welding Procedure Specification, dWPS) and WeldEye cloud service require a valid Kemppi WeldEye subscription with the Welding Procedures module. For more information on WeldEye, refer to weldeye.com or contact your Kemppi representative.

Digital Welding Procedure Specification (dWPS) is a WPS in digital format that can be set to observe the welding parameters of the Master M 358 equipment. The WPSes can be read on the control panel display and/or a memory channel can be linked with a WPS. The Master M 358 control panel provides a couple of ways to achieve this:

- >> In the main **WPS view**: Follow the more detailed steps in "Control panel: WPS view" on page 44.
- >> In the **Memory channels view** via activating an existing memory channel: Open the memory channel 'Actions' and choose to link it with a WPS. In the view that opens, select the WPS and weld pass information to be linked with the memory channel. More detailed information on memory channels is in "Control panel: Channels" on page 42.

3.4.12 WELDEYE

*The use of this WeldEye feature and cloud service require an up-to-date Master M 358 equipment and a valid **Kemppi WeldEye Quality Management** subscription. For more information on WeldEye, refer to weldeye.com or contact your Kemppi representative.*

The WeldEye feature in the Master M 358 equipment is designed to be used in welding quality management. This includes cloud-based tracking of the welding operations carried out with the welding equipment.

Some of the feature highlights:

- Work orders
- Work completion and heat input reporting
- WPS (Welding Procedure Specification) compliance verification
- Welder qualification verification.

The built-in WeldEye feature collects and passes on welding data, keeping it synchronized between the welding equipment and WeldEye cloud service. The WeldEye cloud service can be accessed using a desktop computer and an internet browser.

- >> To take the WeldEye feature in use, the equipment must be connected to the internet via the built-in wireless connection (WLAN). Refer to "Wireless connection (WLAN)" on page 74 for instructions.
- >> To use the WeldEye feature, refer to "Control panel: WeldEye" on page 47.

Other WeldEye options with the Master M 358 equipment:

- >> "Digital Welding Procedure Specification (dWPS)" on the previous page
- >> "WeldEye ArcVision" below
- >> "WeldEye with DCM" on the next page.

3.4.13 WELDEYE ARCVISION

The use of WeldEye cloud service requires a valid Kemppi WeldEye subscription. The Master M 358 equipment includes a link to a free trial registration – featuring also a free trial option for WeldEye ArcVision. For more information on WeldEye, refer to weldeye.com or contact your Kemppi representative.



The WeldEye's ArcVision module is intended for cloud-based tracking of the welding operations carried out with the welding equipment. The ArcVision on the welding device itself is a connection feature for connecting to the WeldEye cloud service. The actual welding information gathered by the welding equipment is passed on to the WeldEye cloud where it can be accessed using a desktop computer and an internet browser.

To take the WeldEye ArcVision feature in use, the equipment must be connected to the internet via the built-in wireless connection (WLAN). Refer to "Wireless connection (WLAN)" on page 74 for instructions.

Master M 358 comes preinstalled with a trial license for ArcVision. The trial license can be activated by following these steps:

1. On the Master M 358 control panel, go to the **WPS view**.
2. Use a QR code reader on your mobile device to open the WeldEye web link or navigate to 'https://register.weldeye.io/weldeye' on your web browser.



3. Complete the registration process as instructed on the registration page. Once finished, the equipment is connected to WeldEye ArcVision.
-  You will be required to fill in the serial number and four-digit security pin of your Master M 358 machine. These can be found on the machine's rating plate.
 -  The free trial registration includes both the WeldEye Welding Procedures and WeldEye ArcVision modules.

3.4.14 WELDEYE WITH DCM

With Master M 358, the WeldEye connection option is built-in. The WeldEye welding management software is also available for use with an additional Digital Connectivity Module (DCM) device. DCM is connected directly to the Master M 358 machine's control connection with the cables and adapters delivered with the DCM device.

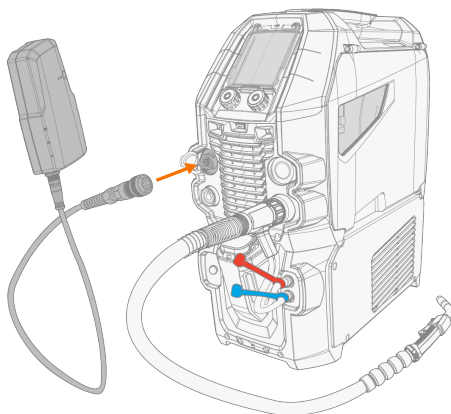

For more information on installing and using the DCM device, refer to userdoc.kemppi.com (DCM/WeldEye).

Discover WeldEye – universal welding management software

WeldEye is your primary tool and storage space for keeping your welding-related documents in order. WeldEye is a universal solution for managing welding production.

WeldEye's modular structure is based on various useful functions that serve the needs of wide-ranging industries and welding-related tasks:

- **Welding procedures**
 - >> Includes the digital library and management of pWPS, WPQR and WPS templates according to the most important welding standards.
- **Personnel and qualifications**
 - >> Includes the management and renewal processes of all personnel - welders and inspectors - qualification certificates.
- **Quality management**
 - >> Includes quality verification functionalities with digital WPS and qualification compliance control against automatically collected digital welding data.
- **Welding management**
 - >> Includes document register functionalities and features for comprehensive welding project documentation and management.

For more information on WeldEye, refer to www.weldeye.com.

3.4.15 USB BACKUP AND RESTORE

The USB backup feature allows the current welding parameters, memory channels and other settings to be backed up on a USB memory stick.

1. Turn the welding machine on.
2. If creating a backup, go to the device settings and select **Backup**.
3. If restoring from a backup, go to the device settings and select **Restore**.
4. Open the USB connector cover and connect the USB memory stick to the Master M 358 control panel.

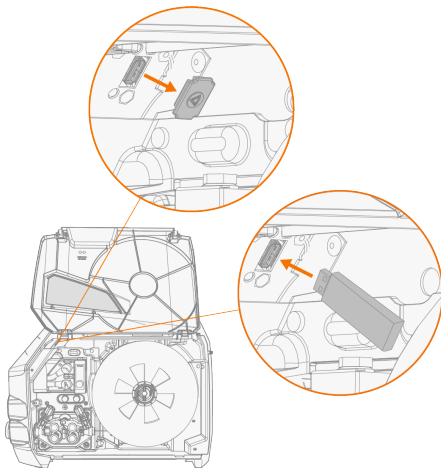

5. Follow the steps on the control panel screen to complete the backup/restore operation.

3.4.16 USB UPDATE

The USB update feature allows the firmware to be updated as well as welding programs, processes and features to be installed using a USB memory stick.

- i** *There can be only one ZIP file on the USB memory stick inserted into the welding system at once. This can be either a dedicated firmware pack for this welding system or a welding program and license pack (matching the power source serial number). For more information on the available software and compatibility, contact your local Kemppi representative.*

Firmware and welding software

1. Ensure you have the correct firmware/software ZIP package saved on your computer for the welding equipment in question.
2. Connect the USB memory stick to the computer.
3. Prepare the USB memory stick by copying the firmware/software ZIP file into the root folder of the memory stick.
4. Turn the welding equipment on.
5. Open the USB connector cover and connect the USB memory stick to the Master M 358 control panel.

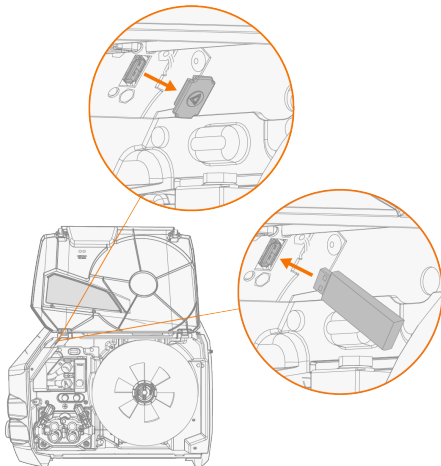

6. The update process starts automatically. Follow the on-screen instructions.

Custom screensaver image

The custom screensaver image must first be prepared at <https://kemp.cc/screensaver> and then copied onto the USB memory stick. The supported image file formats are JPG, PNG and GIF.

1. On your computer web browser, go to <https://kemp.cc/screensaver>.
2. Following the on-screen instructions, upload, edit and download the new screen saver image onto a USB memory stick.
3. Connect the USB memory stick to the Master M 358 control panel following the same principle as with the software updates (previous chapter) and the on-screen instructions.

The screensaver image is shown during start-up and when the control panel has been idle for a predefined time. The screensaver settings can be adjusted in "Control panel: Device settings" on page 63.

3.4.17 CYCLE TIMER

Cycle timer is a welding function that automatically produces a single weld or multiple welds of predefined duration with a press of the welding gun trigger. For example, this can be used to maintain weld consistency when creating a single weld (A) or an intermittent weld (B), or to easily create clean tack welds with low heat input.

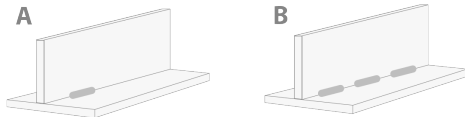

- >> To take Cycle timer in use, go to the **Welding parameters view** and set Cycle timer to ON.
- >> Once Cycle timer is turned on, the Cycle arc time (the duration of the weld) can be adjusted.

When only the Cycle arc time is set, only one single weld is created. The intermittent weld feature is enabled by setting also the Cycle pause time.

- >> To turn the Cycle timer's intermittent weld feature on, go to the **Welding parameters view** and set Cycle timer to ON, set also Cycle pause to ON and adjust the Cycle pause time (the pause duration before the next weld).

With Cycle timer, the weld start and stop features such as pre gas, post gas, upslope, hot start, creep start and crater fill, are available for adjustment according to the selected welding process. Note that using these features with Cycle timer also has an effect on the actual weld duration and that the Cycle arc time setting does not include these.

3.4.18 DEMO TIME

The demo time feature allows a free test evaluation of MAX and Wise welding software. Demo time is available (starting from October 2023) in all new Master M 358 equipment.

The total available demo time is 3 hours. The demo time passes only when welding using a welding feature you don't have a license for. When the demo time is set to ON, the remaining time is shown on the display.

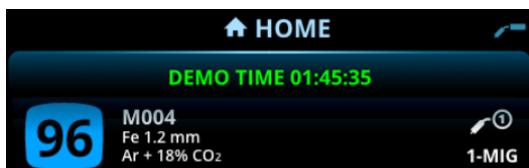

Available for test evaluation are:

- **WisePenetration**
>> For more information, refer to "WisePenetration feature" on page 71.
- **MAX Cool**
>> For more information, refer to "MAX Cool process" on page 72.
- **MAX Speed**
>> For more information, refer to "MAX Speed process" on page 73.
- **MAX Position**
>> For more information, refer to "MAX Position process" on page 73.

The demo time feature can be turned on and off in "Control panel: Device settings" on page 63. By default, the demo time is set to OFF.

When the demo time expires, the features without a license cannot be used anymore. To continue using the optional features, you must buy licenses for them.

3.4.19 SETTINGS LOCK

Settings lock is used to restrict changes to a predefined set of welding parameters and device settings. A PIN code is defined for the settings lock.

- >> To take the settings lock feature in use the first time, go to the [Device settings view](#), select 'Settings lock' and enable the lock by defining a PIN code for it: Select 'Define PIN' and enter a 4-digit PIN code.
- >> To lock/unlock, select settings lock in the [Device settings view](#). When unlocking, enter also the defined settings lock PIN code when requested.

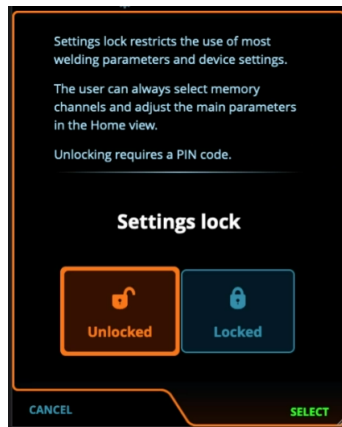

Some of the basic welding parameters and user-specific device settings always remain unlocked and available for adjustment.

3.5 USING REMOTE CONTROL HR43/HR40

The HR40 or HR43 remote controls are taken into use in the control panel settings ("Control panel: Device settings" on page 63).

 *With HR40/HR43 remote control, the minimum and maximum values affect also the resolution of the remote control adjustment.*

Remote control HR43

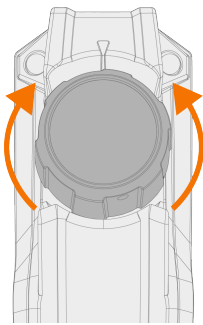

The HR43 control knob function is defined by the selected welding process and reflects the adjustment of the control panel's left control knob.

To adjust the welding parameter, turn the knob on the remote control.

In MIG/MAG: The adjusted parameter can be selected between wire feed speed and memory channel in the control panel settings.

Remote control HR40

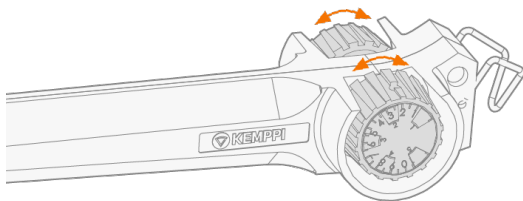

The HR40 control knob functions are defined by the selected welding process and reflect the adjustments of the control panel's two control knobs.

In MIG/MAG: The adjusted parameter can be selected between wire feed speed and memory channel in the control panel settings. When the remote mode is set to 'channel', only the left remote control knob is in use.

3.6 USING REMOTE CONTROL HR55

When connected, the HR55 remote control is automatically in use.

With the optional HR55 remote control, you can select memory channels and adjust wire feed speed, welding current, welding voltage or voltage fine tuning depending on the welding process and the features supported by the connected Master M equipment.

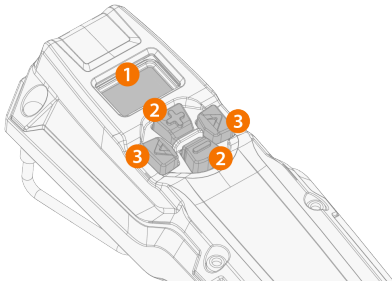

1. LCD display
 - >> Displays the adjusted parameter and notifies if there is an error ("Err") in the welding system.
2. Plus/minus (+/-) buttons
 - >> Changes the parameter value.
3. Left/right arrow buttons
 - >> Changes between adjustable parameters/views.

Remote control display items

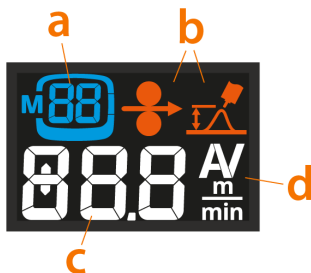

- a. Process and/or selected memory channel information (process is indicated with a single letter: M = MIG/MAG, t = TIG, S = MMA)
- b. MIG/MAG: Wire feed speed and fine tuning symbols
- c. Adjusted parameter value (or error indicator)
- d. Adjusted parameter unit

When the parameter is adjusted with the remote and the parameter value doesn't reflect the one saved on the selected memory channel anymore, this is indicated on the display by showing only the memory channel number without the channel box around it (MIG/MAG only):

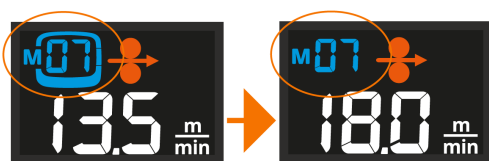

Remote control views and operation

Change between the views by pressing the left/right arrow buttons.

- **Memory channel view (MIG/MAG only):** The memory channel is changed by pressing the +/- buttons. Long press of a +/- button scrolls the parameter values faster.
- **Process selection view:** This allows selecting between MIG/MAG, TIG and MMA welding.
- **Welding power view:** Depending on the used welding process, wire feed speed or current is adjusted by pressing the +/- buttons. Long press of a +/- button scrolls the parameter values faster.
- **Voltage/Fine tuning view:** Depending on the welding process used, voltage or welding process specific parameter is adjusted by pressing the +/- buttons. Long press of the +/- button scrolls the parameter values faster. Long press of the right arrow button switches between different parameter sets, as applicable.
- **Safety lock:** By pressing the left/right arrow buttons simultaneously for 2 seconds, the equipment safety lock can be enabled and disabled.

Long press of the left arrow button saves the adjusted parameters on the currently selected channel.

-  *When a MIG welding torch remote control is used to select a memory channel or adjust the wire feed speed, the corresponding function is disabled in the HR55 remote control.*

3.7 CHANGING WELDING POLARITY

Welding polarity needs to be changed for TIG welding. Also, some filler wires require changing the welding polarity. Check the recommended welding polarity on the filler wire package.

 *Before handling electrical parts, ensure the welding device is disconnected from the mains.*

Tools needed:



17 mm

1. Turn off the welding device and disconnect it from the mains.
2. Open the wire feed cabinet hatch.
3. Remove the protective rubber covers from the polarity terminals.

 *Use caution when handling electrical parts.*

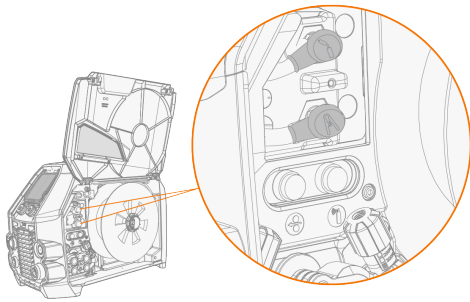

4. Remove the terminal tightening bolts and washers.

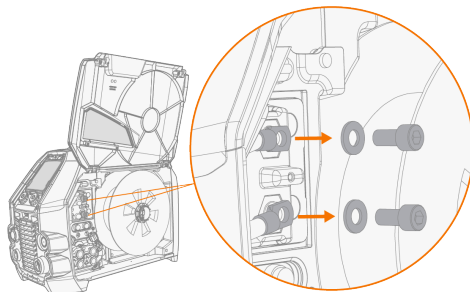

5. Connect the cables to the polarity terminals according to the polarity recommendation.
6. Replace the washers and bolts. Tighten to 17 Nm torque.
7. Replace the protective rubber covers.

3.8 LIFTING EQUIPMENT

 *If a gas bottle is installed on cart, DO NOT attempt to lift the cart with the gas bottle in place.*

4-wheel cart:

1. Ensure that the welding equipment is properly secured to the cart.
2. Connect the 4-legged chain or straps from the hoist hook to the four lifting points on the cart on both sides of the welding equipment.

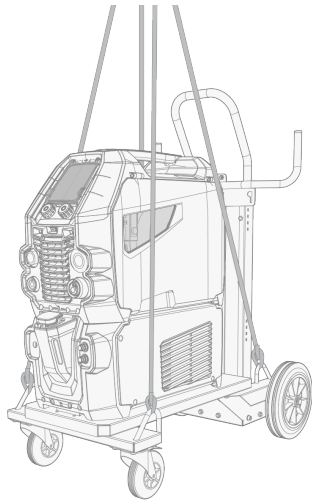

2-wheel cart (T25MT only):

1. Ensure that the welding equipment is properly secured to the cart.
2. Connect the hoist hook to the lifting handle on the cart.

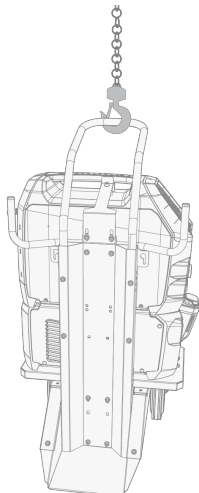

 *Do not lift the equipment when it is installed on the T35A cart.*

4. MAINTENANCE





4.1 DAILY, PERIODIC AND ANNUAL MAINTENANCE

When considering and planning routine maintenance, consider the operating frequency of the welding system and the working environment.

Correct operation of the welding machine, regular maintenance, and the use of original Kemppi spare parts and consumables help you avoid unnecessary downtime and equipment failure, while also maximizing the equipment's service life.

Use pre-mixed coolant solution in the cooling unit. The mixing ratio should be 20...50% as standard. Use only ethylene or propylene glycol mixture intended for welding cooling systems, for example Kemppi cooling liquid. Do not add water to the pre-mixed coolant solution. Do not use automotive cooling solutions or ethanol-based mixtures.

For repairs, find your closest Kemppi service workshop at www.kemppi.com or contact your dealer.

-  *Only an authorized electrician is allowed to carry out electrical work.*
-  *Only qualified service personnel is allowed to carry out periodic and annual maintenance.*
-  *Disconnect the power source from the mains before handling electrical cables and connectors.*
-  *Do not use pressure washing devices.*
-  *Where applicable, use the correct tension torque when fastening loose parts.*

Daily maintenance

Welding equipment's daily maintenance:

- Check that all covers and components are intact.
- Check all the cables, hoses and connectors. Do not use them if they are damaged.
- Ensure that the connectors are correctly fastened. Loose connectors can impair welding performance and damage connectors.
- Check the wire feeder's feed rolls and the pressure handle mechanism. Clean and lubricate with a small quantity of light machine oil if needed.

Cooling unit's daily maintenance (in addition):

- Check the cooling liquid level. Add cooling liquid if needed. Note: Use the correct coolant solution (see above).
- Check the cooling unit surroundings for cooling liquid leakages. If there are signs of significant leakage, contact Kemppi service.
- Check and test the cooling liquid pump operation by circulating the cooling liquid.

Weekly maintenance

Welding equipment's weekly maintenance:

- Clean the outside parts of the units from dust and dirt, for example, with a soft brush and vacuum cleaner.
- Clean the ventilation grills. Do not use compressed air, there is a risk that the dirt will compact even more tightly into the gaps of the cooling profiles.
- If air filters are used, remove them and clean them by blowing with compressed air.

Periodic maintenance

Welding equipment's periodic maintenance, every 1–6 months:

- Check the electrical connectors of the equipment at least every 6 months. Clean oxidized parts and tighten loose connectors.
- Update the welding system to the latest firmware and software versions, as applicable.

Cooling unit's periodic maintenance, every 1–6 months (in addition):

- Check the cooling liquid quality at least once a month. Ensure that the liquid is clear and free of any visible impurities.
- Replace the cooling liquid every 6 months. Note: Use the correct coolant solution (see above).

Annual maintenance

The annual maintenance must be carried out by an authorized Kemppi service workshop. Kemppi service workshops complete the welding system maintenance according to your Kemppi service agreement. Find your closest service workshop at www.kemppi.com.

Welding equipment's annual maintenance program includes:

- Cleaning the equipment.
- Maintenance of the welding tools.
- Checking the connectors and switches.
- Checking all electrical connections.
- Checking the power source mains cable and plug.
- Repairing defective parts and replacing defective components.
- Maintenance test.
- Testing the operation and calibrating the performance values when needed.
- Updating the welding system to the latest firmware and software versions, and installing new welding software.
- If a cooling unit is used: Checking and cleaning the cooling liquid pump. The pump is dismantled and cleaned thoroughly, and if there has been any leakage in the pump's axle seal point, the axle seal is replaced. The axle seal is subject to wear and may need replacement periodically to maintain proper sealing.

For Kemppi welding torch maintenance, refer to your welding torch's instructions (available also at user-doc.kemppi.com).

4.2 INSTALLING AND CLEANING POWER SOURCE AIR FILTER (OPTIONAL)

An optional power source air filter can be purchased separately. The air filter comes with a fixed casing designed to be mounted directly onto the power source air intake.

i Using the optional air filter decreases the rated power levels of the power source as follows (output 40 °C): 60% >>> 45% and 100% >>> 100%-20A. This is due to the slightly reduced cooling air intake.

Tools needed:



Installation and replacement

1. Place the air filter assembly onto the power source air intake, and lock it in place with the clips on the edge of the casing.

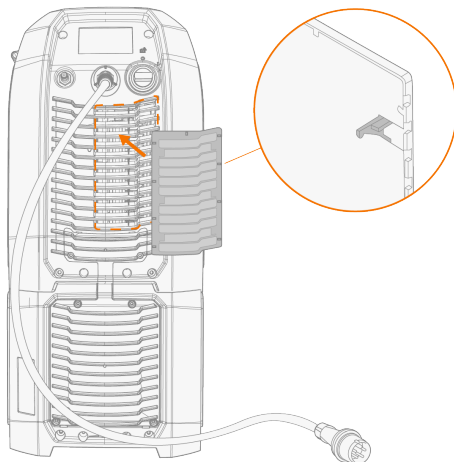

Cleansing

1. Remove the air filter from the power source by releasing the clips on the edge of the air filter casing.
2. Blow the air filter clean with compressed air.

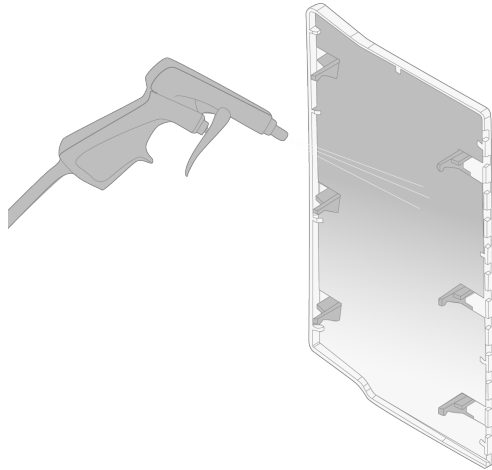

4.3 TROUBLESHOOTING

i *The problems listed and the possible causes are not definitive, but suggest some typical situations that may turn up during normal use of the welding system.*

Welding device:

Problem	Recommended actions
The welding device does not power up	Check that the mains cable is plugged in properly.
	Check that the mains switch of the power source is at the ON position.
	Check that the mains power distribution is on.
	Check the mains fuse and/or the circuit breaker.
	Check that the interconnection cable between the power source and the wire feeder is intact and properly attached.
	Check that the earth return cable is connected.
The welding device stops working	Gas-cooled torch may have overheated. Wait for it to cool down.
	Check that none of the cables is loose.
	The wire feeder may have overheated. Wait for it to cool down and see that the welding current cable is properly attached.
	The power source may have overheated. Wait for it to cool down and see that the cooling fans work properly and the air flow is unobstructed.

Wire feeding:

Problem	Recommended actions
The filler wire on the spool unravels	Check that the spool locking cover is closed.
The wire feed mechanism does not feed the filler wire	Check that the filler wire has not run out.
	Check that the filler wire is properly routed through the feed rolls to the wire liner.
	Check that the pressure handle is properly closed.
	Check that the feed roll pressure is adjusted correctly for the filler wire.
	Check that the welding cable is properly connected to the wire feeder.
	Blow compressed air through the wire liner to check that it is not blocked.

Weld quality:

Problem	Recommended actions
---------	---------------------

Dirty and/or poor quality weld	Check that the shielding gas has not run out.
	Check that the shielding gas flow is unobstructed.
	Check that the gas type is correct for the application.
	Check the polarity of the torch/electrode.
	Check that the welding procedure is correct for the application.
Varying welding performance	Check that the wire feed mechanism is adjusted properly.
	Blow compressed air through the wire liner to check that it is not blocked.
	Check that the wire liner is correct for the selected wire size and type.
	Check the welding torch contact tip's size, type and wear.
	Check that the welding torch is not overheating.
	Check that the earth return clamp is properly attached to a clean surface of the workpiece.
High spatter volume	Check the welding parameter values and welding procedure.
	Check the gas type and flow.
	Check the polarity of the torch/electrode.
	Check that the filler wire is correct for the current application.

"Error codes" below

4.3.1 ERROR CODES

In error situations, the control panel displays the number, title and possible cause of the error, and a proposed action to fix the issue.

Error			
Code	Title	Possible cause	Proposed action
1	Power source not calibrated	Power source calibration has been lost.	Restart the power source. If problem persists, contact Kemppi service.
2	Too low mains voltage	Voltage in mains network is too low.	Restart the power source. If problem persists, contact Kemppi service.
3	Too high mains voltage	Voltage in mains network is too high.	Restart the power source. If problem persists, contact Kemppi service.
4	Power source is overheated	Too long welding session with high power.	Do not shut down, let the fans cool the machine. If fans are not running, contact Kemppi service
5	Internal 24V voltage is too low	Power source contains an inoperative 24V power supply unit .	Restart the power source. If problem persists, contact Kemppi service.

10	Unsupported welding process	There is an unsupported welding process in the memory channel.	Check that all memory channel definitions are supported.
12	Welding cable failure	Plus and minus cables are connected together.	Check the connections of welding cable and earth return cable.
13	IGBT over-current	Inoperative mains transformer in power source.	Restart the power source. If problem persists, contact Kemppi service.
14	IGBT overheated	Too long welding session with high power or high ambient temperature.	Do not shut down, let the fans cool the machine. If fans are not running, contact Kemppi service.
16	Main transformer is overheated	Too long welding session with high power or high ambient temperature.	Do not shut down, let the fans cool the machine. If fans are not running, contact Kemppi service.
17	Phase is missing from mains supply	One or more phases are missing from the mains supply.	Check the mains cable and its connectors. Check the voltage of mains supply.
20	Power source cooling failure	Cooling capacity is reduced in the power source.	Clean the filters and clear any dirt from the cooling channel. Check that the cooling fans are running. If not, contact Kemppi service.
24	Cooling liquid overheated	Too long welding session with high power or high ambient temperature.	Do not turn off the cooler. Let the liquid circulate until the fans cool it down. If fans are not running, contact Kemppi service.
26	Cooling liquid not circulating	No cooling liquid or circulation is blocked.	Check the liquid level in the cooler. Check hoses and connectors for blockage.
27	Cooler not found	Cooling is turned on in the settings menu, but cooler is not connected to power source or cabling is faulty.	Check the cooler connections. Ensure that the cooling is turned off in the settings menu, if the cooler is not in use.
33	Welding cable calibration failure	Welding cable calibration failed.	Check the welding system cables and their connections.
35	Too high mains current	Current drawn from the mains is too high.	Reduce welding power.
40	VRD error	Open circuit voltage exceeds the VRD limit.	Restart the power source. If problem persists, contact Kemppi service.
42	High current in wire feeder motor	There may be too much pressure in the wire feed rolls or dirt in the wire line.	Adjust the feed roll pressure. Clean the wire line. Change worn parts in the welding torch.
43	Overcurrent in wire feeder motor	There may be too much pressure in the wire feed rolls or dirt in the wire line.	Adjust the feed roll pressure. Clean the wire line. Change worn parts in the welding torch.
44	Wire speed measurement is missing	Faulty sensor or wiring in wire feeder.	Restart the welding system. If problem persists, contact Kemppi service.
45	Low gas pressure	Shielding gas pressure is too low.	Check and adjust the shielding gas flow.
50	License error	License for the selected feature is missing.	To continue using the feature, please install the license.

61	Operation is not allowed	Subfeeder is connected, but it has not been selected in the system settings.	Go to the system settings menu on the control panel and select your subfeeder model and type.
64	Robot control device lost	Wire feeder lost connection to the robot control device.	Check the robot control device and inter-connection cables. If problem persists, contact Kemppi service.
65	Subfeeder not allowed	Use of subfeeder is not allowed with selected welding process.	Remove the subfeeder or change the welding process.
103	Empty memory channel	Robot tried to start welding using a nonexistent memory channel.	Check the memory channel selected by the robot.
132	Robot not responding	There is a communication problem between robot and the RCM.	Check fieldbus cabling, connectors and the fieldbus module.
244	Internal memory failure	Initialization failed (%sub:%device).	Restart welding system. If problem persists, contact Kemppi service.
245	Demo time left: %min min	When the demo time expires, the features without a license cannot be used anymore.	To continue using the optional features, you must buy licenses for them.
246	Demo time has expired	Features without a license cannot be used anymore.	To continue using the optional features, you must buy licenses for them.
250	Internal memory failure	Memory communication failed (%sub:%device).	Restart welding system. If problem persists, contact Kemppi service.

4.4 DISPOSAL



Do not dispose of any electrical equipment with normal waste!

In observance of WEEE Directive 2012/19/EU on waste of electrical and electronic equipment and European Directive 2011/65/EU on the restriction of the use of certain hazardous substances in electrical and electronic equipment, and their implementation in accordance with national law, electrical equipment that has reached the end of its life must be collected separately and taken to an appropriate environmentally responsible recycling facility. The owner of the equipment is obliged to deliver a decommissioned unit to a regional collection center, as per the instructions of local authorities or a Kemppli representative. By applying these European Directives you improve the environment and human health.

For more information:



5. TECHNICAL DATA

Technical data:

- For Master M 358 device technical data, refer to "Master M 358 device" on the next page.
- For Master M Cooler cooling unit technical data, refer to "Master M cooling unit" on page 104.

Additional information:

- For ordering information, refer to "Master M 358 ordering info" on page 105.
- For wire feeder consumable information, refer to "Wire feeder consumables" on page 106.
- For welding program work packs, refer to "Welding program work packs" on page 108.

5.1 MASTER M 358 DEVICE

Master M 358 G

Master M 358 G		
Feature		Value
Mains connection voltage		380...460 V \pm 10 %
Mains connection phases		3~50/60 Hz
Mains connection cable type		H07RN-F
Mains connection cable size		4 mm ²
Rated maximum input power [S_{1max}]		14 kVA
Mains fuse		16 A
Idle state power consumption [P_{idle}]		18 W
No-load state power consumption (MMA), power save		18 W
No-load state power consumption (MMA), fans ON		119 W
No-load voltage [U_0]		55...69 V
Open circuit voltage [U_{av}]		53...64 V
Effective supply current [I_{1eff}]		13.5...10.8 A
Maximum supply current [I_{1max}]		21.3...17.1 A
Output, duty cycle % at rated max current, MIG		40 %
Output at +40 °C, rated max current, MIG		350 A
Output at +40 °C, 60% MIG		280 A
Output at +40 °C, 100% MIG		220 A
Output range, MIG welding current/voltage		15 A / 10 V ... 350 A / 45 V
Output range, TIG welding current/voltage		15 A / 1 V ... 350 A / 45 V
Output range, MMA welding current/voltage		15 A / 10 V ... 330 A / 45 V
Voltage adjustment range (MIG)		10...40 V
VRD voltage		24 V
Power factor at rated maximum current	λ	0.91
Efficiency at rated maximum current	η	87 %
Minimum short-circuit power of supply network [S_{SC}]		2.4 MVA
Voltage supply for auxiliary devices		12 V
Voltage supply for cooling unit		24 V, 380...460 V
Welding connection type		Euro
Wire feed mechanism		4-roll, Single-motor
Diameter of feed rolls		32 mm
Filler wire diameter, Fe		0.8...1.2 mm

Filler wire diameter, Ss	0.8...1.2 mm
Filler wire diameter, MC/FC	0.8...1.2 mm
Filler wire diameter, Al	0.8...1.2 mm
Wire feed speed	0.5...25 m/min
Maximum wire spool weight	20 kg
Maximum wire spool diameter	300 mm
Maximum shielding gas pressure	0.5 MPa
Control panel, model	Master M 358 Panel APC
Control panel, display	5.7" LCD
Control panel, controls	2 control knobs, Push buttons
Control panel, type of installation	Built-in
Control panel, input voltage (DC)	12 V
Wired communication type	CAN bus
Wireless communication type	WUBT-236ACN(BT)
Bluetooth type	4.2 (LE)
Transmitter frequency and power, Bluetooth	2.4 GHz; 4 dBm
WLAN type	IEEE 802.11 ac/a/b/g/n
Transmitter frequency and power, WLAN	2.4 GHz: 2.412...2.484 GHz; 5.1 GHz: 5.150...5.240 GHz, 5.250...5.350 GHz, 5.470...5.725 GHz; 9...16 dBm
LED battery type and voltage	SAMSUNG SDI (INR18650-26J; 3,6 V; 2600 mAh); LG CHEM (ICR18650HE4; 3,6 V; 2500 mAh)
Operating temperature range	-20...40 °C
Storage temperature range	-40...60 °C
Recommended minimum generator power [S_{gen}]	20 kVA
EMC class	A
Degree of protection	IP23S
External dimensions	<i>L x W x H</i> 602 x 298 x 447 mm
Weight without accessories	27 kg
Standards	IEC 60974-1, -10

Master M 358 GM

Master M 358 GM	
Feature	Value
Mains connection voltage	380...460 V ±10 %
Mains connection voltage	MV low range 220...230 V ±10 %
Mains connection phases	3~50/60 Hz
Mains connection cable type	H07RN-F
Mains connection cable size	4 mm ²

Rated maximum input power [S_{1max}]		14 kVA
Mains fuse		16 A
Mains fuse	@MV low range	32 A
Idle state power consumption [P_{idle}]		20 W
No-load state power consumption (MMA), power save		20 W
No-load state power consumption (MMA), fans ON		120 W
No-load voltage [U_0]		55...69 V
No-load voltage [U_0]	@MV low range	54...56 V
Open circuit voltage [U_{av}]		53...64 V
Effective supply current [I_{1eff}]		13.3...10.8 A
Effective supply current [I_{1eff}]	@MV low range	18 A
Maximum supply current [I_{1max}]		21.1...17.1 A
Maximum supply current [I_{1max}]	@MV low range	28.4 A
Output, duty cycle % at rated max current, MIG		40 %
Output at +40 °C, rated max current, MIG		350 A
Output at +40 °C, 60% MIG		280 A
Output at +40 °C, 100% MIG		220 A
Output at +40 °C, rated max current, MIG	@MV low range	300 A
Output at +40 °C, 60% MIG	@MV low range	240 A
Output at +40 °C, 100% MIG	@MV low range	190 A
Output range, MIG welding current/voltage		15 A / 10 V ... 350 A / 45 V
Output range, TIG welding current/voltage		15 A / 1 V ... 350 A / 45 V
Output range, MMA welding current/voltage		15 A / 10 V ... 330 A / 45 V
Output range, MIG welding current/voltage	@MV low range	15 A / 10 V ... 300 A / 40 V
Output range, TIG welding current/voltage	@MV low range	15 A / 1 V ... 300 A / 40 V
Output range, MMA welding current/voltage	@MV low range	15 A / 10 V ... 280 A / 40 V
Voltage adjustment range (MIG)		10...40 V
VRD voltage		24 V
Power factor at rated maximum current	λ	0.91
Efficiency at rated maximum current	η	87 %
Minimum short-circuit power of supply network [S_{sc}]		2.4 MVA
Voltage supply for auxiliary devices		12 V
Voltage supply for cooling unit		24 V, 380...460 V
Voltage supply for cooling unit	@MV low range	220...230 V, 24 V
Welding connection type		Euro
Wire feed mechanism		4-roll, Single-motor

Diameter of feed rolls	32 mm
Filler wire diameter, Fe	0.8...1.2 mm
Filler wire diameter, Ss	0.8...1.2 mm
Filler wire diameter, MC/FC	0.8...1.2 mm
Filler wire diameter, Al	0.8...1.2 mm
Wire feed speed	0.5...25 m/min
Maximum wire spool weight	20 kg
Maximum wire spool diameter	300 mm
Maximum shielding gas pressure	0.5 MPa
Control panel, model	Master M 358 Panel APC
Control panel, display	5.7" LCD
Control panel, controls	2 control knobs, Push buttons
Control panel, type of installation	Built-in
Control panel, input voltage (DC)	12 V
Wired communication type	CAN bus
Wireless communication type	WUBT-236ACN(BT)
Bluetooth type	4.2 (LE)
Transmitter frequency and power, Bluetooth	2.4 GHz; 4 dBm
WLAN type	IEEE 802.11 ac/a/b/g/n
Transmitter frequency and power, WLAN	2.4 GHz: 2.412...2.484 GHz; 5.1 GHz: 5.150...5.240 GHz, 5.250...5.350 GHz, 5.470...5.725 GHz; 9...16 dBm
LED battery type and voltage	SAMSUNG SDI (INR18650-26J; 3,6 V; 2600 mAh); LG CHEM (ICR18650HE4; 3,6 V; 2500 mAh)
Operating temperature range	-20...40 °C
Storage temperature range	-40...60 °C
Recommended minimum generator power [S_{gen}]	20 kVA
EMC class	A
Degree of protection	IP23S
External dimensions	<i>L x W x H</i> 602 x 298 x 447 mm
Weight without accessories	27 kg
Standards	IEC 60974-1, -10

Master M 358 control panel

Master M 358 control panel	
Feature	Value
Model designation	Master M 358 Panel APC
Type of installation	Built-in / preinstalled

Controls	- 2 control knobs with push button function - 3 shortcut buttons
Display	5.7" LCD
Rating	12 V DC ($\pm 10\%$) (Host device power output to control panel shall not exceed 15W)
Wireless communication type	WUBT-236ACN(BT)
- Wireless local area network (WLAN) standard	IEEE 802.11 ac/a/b/g/n
- Transmitter frequency and power, WLAN	2.4 GHz: 2.412...2.484 GHz; 5.1 GHz: 5.150...5.240 GHz, 5.250...5.350 GHz, 5.470...5.725 GHz; 9...16 dBm

5.2 MASTER M COOLING UNIT

Master M Cooler

Master M Cooler		
Feature		Value
Supply voltage		380...460 V \pm 10 %
Idle state power consumption [P_{idle}]		3 W
Maximum supply current [I_{max}]		0.7 A
Cooling power at 1 l/min		1 kW
Maximum coolant pressure		4 Bar
Recommended coolant		Kemppi MGP 4456
Operating temperature range		-20...40 °C
Storage temperature range		-40...60 °C
EMC class		A
Degree of protection		IP23S
Tank volume		3 l
External dimensions	<i>L x W x H</i>	635 x 305 x 292 mm
Weight without accessories		14.9 kg
Standards		IEC 60974-2, -10

Master M Cooler MV

Master M Cooler MV		
Feature		Value
Supply voltage		380...460 V \pm 10 %
Supply voltage	MV low range	220...230 V \pm 10 %
Idle state power consumption [P_{idle}]		5 W
Maximum supply current [I_{max}]		0.7 A
Maximum supply current [I_{max}]	@MV low range	1 A
Cooling power at 1 l/min		1 kW
Maximum coolant pressure		4 Bar
Recommended coolant		Kemppi MGP 4456
Operating temperature range		-20...40 °C
Storage temperature range		-40...60 °C
EMC class		A
Degree of protection		IP23S
Tank volume		3 l
External dimensions	<i>L x W x H</i>	635 x 305 x 292 mm
Weight without accessories		14.9 kg
Standards		IEC 60974-2, -10

5.3 MASTER M 358 ORDERING INFO

For Master M 358 ordering information and optional accessories, refer to [Kemppi.com](https://www.kemppi.com).

5.4 WIRE FEEDER CONSUMABLES

This section lists the feed rolls and wire guide tubes available both separately and in consumable kits. The consumable kits contain recommended feed roll and wire guide tube combinations for selected filler wire materials and diameters. The wire feeder consumables can be ordered in [Configurator.kemppi.com](https://configurator.kemppi.com).

In the tables, *standard* refers to plastic feed rolls and *heavy-duty* refers to metal feed rolls. The materials mentioned first refer to primary suitability and the materials mentioned inside brackets refer to secondary suitability.

Wire feeder consumable kits

The table below lists the recommended consumable kits for selected filler wire materials and diameters.

Wire feeder consumable kits				
Filler wire material	Feed roll profile*	Filler wire diameter (mm)	Consumable kit code, standard	Consumable kit code, heavy-duty
Fe (MC/FC)	V-groove	0.8–0.9	F000488	F000492
		1.0	F000489	F000493
		1.2	F000490	F000494
Ss (Fe, Cu)	V-groove	0.8–0.9	F000455	-
		1.0	F000456	-
		1.2	F000457	-
Ss (Fe)	V-groove	0.8–0.9	-	F000458
		1.0	-	F000459
		1.2	-	F000460
MC/FC	V-groove, knurled	1.0	F000499	F000502
		1.2	F000500	F000503
Al	U-groove	1.0	F000461	-
		1.2	F000462	-

Wire guide tubes

The table below lists the wire guide tubes available.

Wire guide tubes				
Filler wire material	Filler wire diameter (mm)	Inlet guide tube	Middle guide tube	Outlet guide tube
Al, Ss (Fe, MC/FC)	0.6	SP007293	SP007273	SP016608
	0.8–0.9	SP007294	SP007274	SP011440
	1.0	SP007295	SP007275	SP011441
	1.2	SP007296	SP007276	SP011442
Fe, MC/FC	0.6	(SP007293)	(SP007273)	SP016613
	0.8–0.9	SP007536	(SP007274)	SP016614
	1.0	SP007537	(SP007275)	SP016615
	1.2	SP007538	(SP007276)	SP016616

Feed rolls



The table below lists the standard feed rolls available.

Feed rolls, standard				
Filler wire material	Feed roll profile*	Filler wire diameter (mm)	Drive roll code	Pressure roll code
Fe, Ss, Cu (Al, MC/FC)	V-groove	0.6	W001045	W001046
		0.8–0.9	W001047	W001048
		1.0	W000675	W000676
		1.2	W000960	W000961
MC/FC (Fe)	V-groove, knurled	1.0	W001057	W001058
		1.2	W001059	W001060
Al (MC/FC, Ss, Fe, Cu)	U-groove	1.0	W001067	W001068
		1.2	W001069	W001070

The table below lists the heavy-duty feed rolls available.

Feed rolls, heavy-duty				
Filler wire material	Feed roll profile*	Filler wire diameter (mm)	Drive roll code	Pressure roll code
Fe, Ss (MC/FC)	V-groove	0.8–0.9	W006074	W006075
		1.0	W006076	W006077
		1.2	W004754	W004753
MC/FC (Fe)	V-groove, knurled	1.0	W006080	W006081
		1.2	W006082	W006083
(MC/FC, Ss, Fe)	U-groove	1.0	W006088	W006089
		1.2	W006090	W006091

* Feed roll profiles and corresponding symbols:

Feed roll profile	Symbol
V-groove	
V-groove, knurled	
U-groove	

5.5 WELDING PROGRAM WORK PACKS

Welding program work packs include a set of standard welding programs to allow welding with e.g. automatic 1-MIG and pulse processes. For more information on the available Master M welding program options and installing the welding programs or software updates, contact your local Kemppei dealer or go to Kemppei.com.

1-MIG work pack:

Welding program	Process	Wire material	Wire diameter	Shielding gas	Description
A01	1-MIG	AlMg5	1.0	Ar	Standard
A02	1-MIG	AlMg5	1.2	Ar	Standard
A11	1-MIG	AlSi5	1.0	Ar	Standard
A12	1-MIG	AlSi5	1.2	Ar	Standard
C01	1-MIG	CuSi3	0.8	Ar	Standard: Brazing
C03	1-MIG	CuSi3	1.0	Ar	Standard: Brazing
C11	1-MIG	CuAl8	0.8	Ar	Standard: Brazing
C13	1-MIG	CuAl8	1.0	Ar	Standard: Brazing
F01	1-MIG	Fe	0.8	Ar+18%CO2	Standard
F02	1-MIG	Fe	0.9	Ar+18%CO2	Standard
F03	1-MIG	Fe	1.0	Ar+18%CO2	Standard
F04	1-MIG	Fe	1.2	Ar+18%CO2	Standard
F11	1-MIG	Fe	0.8	Ar+8%CO2	Standard
F12	1-MIG	Fe	0.9	Ar+8%CO2	Standard
F13	1-MIG	Fe	1.0	Ar+8%CO2	Standard
F14	1-MIG	Fe	1.2	Ar+8%CO2	Standard
F21	1-MIG	Fe	0.8	CO2	Standard
F22	1-MIG	Fe	0.9	CO2	Standard
F23	1-MIG	Fe	1	CO2	Standard
F24	1-MIG	Fe	1.2	CO2	Standard
M04	1-MIG	Fe Metal	1.2	Ar+18%CO2	Standard
R04	1-MIG	Fe Rutil	1.2	Ar+18%CO2	Standard
S01	1-MIG	Ss	0.8	Ar+2%CO2	Standard
S02	1-MIG	Ss	0.9	Ar+2%CO2	Standard
S03	1-MIG	Ss	1.0	Ar+2%CO2	Standard
S04	1-MIG	Ss	1.2	Ar+2%CO2	Standard
S82	1-MIG	FC-CrNiMo	0.9	Ar+18%CO2	Standard
S84	1-MIG	FC-CrNiMo	1.2	Ar+18%CO2	Standard

Pulse work pack:

The Pulse work pack includes also all 1-MIG work pack welding programs.

Welding program	Process	Wire material	Wire diameter	Shielding gas	Description
A01	Pulse	AlMg5	1.0	Ar	Standard
A02	Pulse	AlMg5	1.2	Ar	Standard
A11	Pulse	AlSi5	1.0	Ar	Standard
A12	Pulse	AlSi5	1.2	Ar	Standard
C01	Pulse	CuSi3	0.8	Ar	Standard: Brazing
C03	Pulse	CuSi3	1.0	Ar	Standard: Brazing
C11	Pulse	CuAl8	0.8	Ar	Standard: Brazing
C13	Pulse	CuAl8	1.0	Ar	Standard: Brazing
F01	Pulse	Fe	0.8	Ar+18%CO2	Standard
F02	Pulse	Fe	0.9	Ar+18%CO2	Standard
F03	Pulse	Fe	1.0	Ar+18%CO2	Standard
F04	Pulse	Fe	1.2	Ar+18%CO2	Standard
F11	Pulse	Fe	0.8	Ar+8%CO2	Standard
F12	Pulse	Fe	0.9	Ar+8%CO2	Standard
F13	Pulse	Fe	1.0	Ar+8%CO2	Standard
F14	Pulse	Fe	1.2	Ar+8%CO2	Standard
M04	Pulse	Fe Metal	1.2	Ar+18%CO2	Standard
S01	Pulse	Ss	0.8	Ar+2%CO2	Standard
S02	Pulse	Ss	0.9	Ar+2%CO2	Standard
S03	Pulse	Ss	1.0	Ar+2%CO2	Standard
S04	Pulse	Ss	1.2	Ar+2%CO2	Standard